

SECTION 5

COOLING SYSTEM

CONTENTS

Cooling System	5
Water Pump	5.1
Water Manifold	5.2
Thermostat	5.2.1
Radiator	5.3
Coolant Pressure Control Cap	5.3.1
Engine Cooling Fan	5.4
Heat Exchanger	5.5
Raw Water Pump (Jabsco)	5.6
Coolant Filter and Conditioner	5.7
Shop Notes – Specifications – Service Tools	5.0

COOLING SYSTEM

To effectively dissipate the heat generated by the engine, one of three different types of cooling systems is used on V-92 engines: radiator and fan, heat exchanger and raw water pump, or keel cooling. Each system is provided with a centrifugal type water pump that circulates the engine coolant. Each system incorporates thermostats to maintain a normal engine operating temperature (refer to Section 13.2).

Upon starting a cold engine or when the coolant is below operating temperature, the coolant flow to the radiator is blocked or restricted by the thermostats in the thermostat housings. A bypass provides coolant circulation within the engine during the warm-up period.

RADIATOR COOLING SYSTEM

Coolant is drawn from the lower portion of the radiator by the water pump and is forced through the oil cooler housing and into the cylinder block (Fig. 1).

From the cylinder block, the coolant passes up through the cylinder heads and, when the engine is at normal operating temperature, through the thermostats into the upper portion of the radiator. The coolant passes down a series of tubes where its temperature is lowered by the air stream created by the revolving fan.

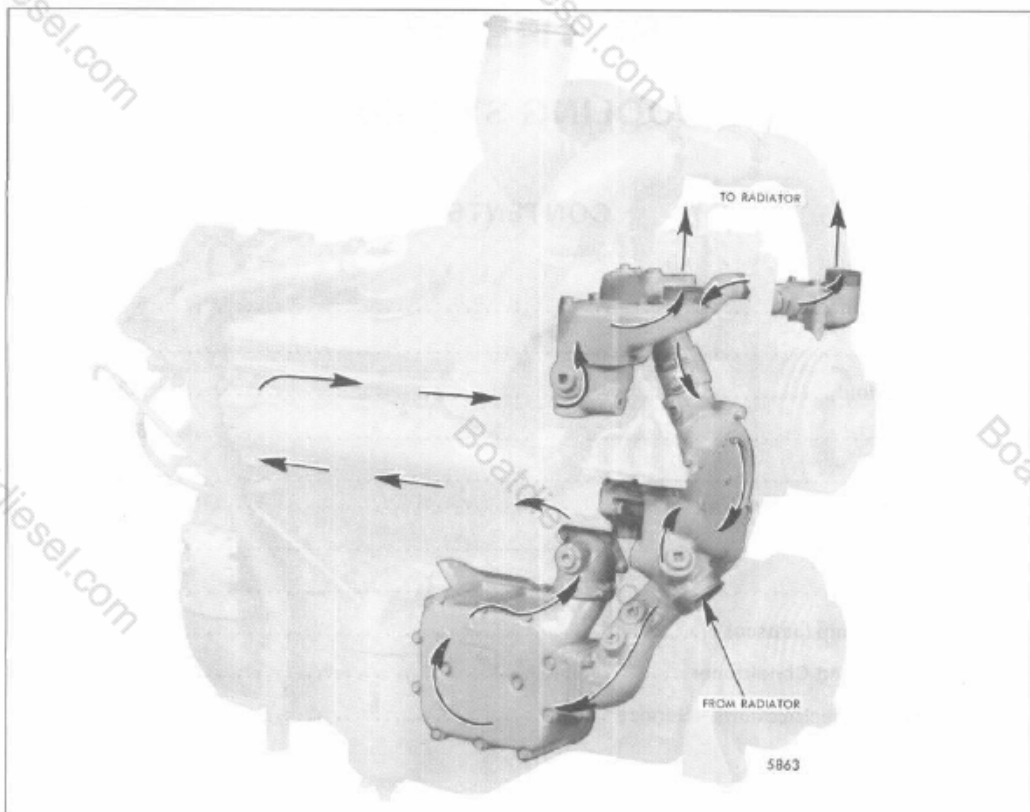

Fig. 1 - Cooling System

HEAT EXCHANGER COOLING SYSTEM

In the heat exchanger cooling system, the coolant is drawn by the engine water pump from the heat exchanger and is forced through the engine oil cooler, cylinder block, cylinder heads and exhaust manifolds to the thermostat housings. A bypass from the thermostat housings to the inlet side of the water pump permits circulation of coolant through the engine when the thermostats are closed.

When the thermostats are open, the coolant flows through the heat exchanger where it is cooled.

An engine driven raw water pump circulates raw water (sea water) through the heat exchanger to lower the temperature of the engine coolant.

KEEL COOLING SYSTEM

In the keel cooling system, the coolant is drawn by the engine water pump from the keel cooler and is forced through the engine oil cooler, cylinder block, cylinder heads and exhaust manifolds to the thermostat housings. A bypass from the thermostat housings to the inlet side of the water pump permits circulation of coolant through the engine

when the thermostats are closed. When the thermostats open, the coolant flows through the keel cooling coils to be cooled.

The heat of the engine coolant is transferred through the coils of the keel cooler to the surrounding sea water.

ENGINE COOLING SYSTEM MAINTENANCE

The function of the engine coolant is to absorb the heat, developed as a result of the combustion process in the cylinders, from components of the engine such as exhaust valves, pistons and cylinder liners which are surrounded by water jackets. In addition, heat absorbed by the oil is also removed by the engine coolant in the oil-to-water oil cooler. When operating within the proper temperature range and not exceeding the recommended horsepower output of the unit, all engine parts will be within their design operating temperature range and at their proper operating clearances. Coolant must be properly selected and maintained (refer to Section 13.3 for coolant recommendations).

A pressurized cooling system, which normally operates at temperatures higher than a non-pressurized system, is used. It is essential that the cooling system is kept clean and leakproof, that the filler cap and pressure relief mechanism be correctly installed and that the coolant level be properly maintained.

CAUTION: Use extreme care when removing a coolant pressure control cap. The sudden release of pressure from a heated cooling system can result in loss of coolant and possible personal injury (scalding) from the hot liquid.

Cooling System Capacity

The capacity of the basic engine cooling system, (cylinder block, cylinder heads, water manifolds, thermostat housings and oil cooler housing) is shown in Table 1. These quantities do not include the capacity of the radiator, hoses or related equipment.

Engine	Cooling System Capacity	
	Gallons	Liters
6V-92, T, TT	6	22.7
6V-92TA, TTA	6-1/8	23.2
8V-92, T, TT	7	26.5
8V-92TA, TTA	7-1/4	27.4
12V-92, T	12	45.4
16V-92, T	14-1/2	54.9
16V-92TA	15	56.8
After Cooler Capacity		
6V-92TA	.169	.64
8V-92TA	.251	.95
16V-92TA	.502	1.90

TABLE 1

Fill Cooling System

Before starting the engine, close all of the drain cocks and fill the cooling system with coolant (Section 13.3). If the unit has a raw water pump, it should be primed, since operation without water may cause impeller failure.

Start the engine and, after the normal operating temperature has been reached, check the coolant level. The coolant level should be within two inches of the top of the filler neck.

Should a daily loss of coolant be observed, and there are no apparent leaks, there is a possibility that gases are leaking past the cylinder head water seal rings into the cooling system. The presence of air or gases in the cooling system may be detected by connecting a rubber tube between the overflow pipe and a container of water. Bubbling of the water in the container during engine operation will indicate leakage. Another method for observing air in the cooling system is by inserting a transparent tube in the engine coolant outlet line.

Drain Cooling System

To ensure that all of the coolant is drained completely from a unit, all cooling system drains should be opened. Should any entrapped water in the cylinder block or radiator freeze, it will expand and may cause damage. When freezing weather is expected, drain all units not adequately protected by antifreeze. Leave all drain cocks open until refilling the cooling system. The engine coolant is drained by opening the drain cocks and removing the cooling system filler cap. Removal of the filler cap permits air to enter the cooling passages and the coolant to drain completely from the system.

On 6V and 8V engines, cylinder block drain cocks are located on each side of the cylinder block at the rear, below the exhaust manifolds and at the front of the engine.

On 12V and 16V engines, a drain cock is located on each side of the cylinder block, below the exhaust manifold, at both the front and the rear of the engine.

In addition to the cylinder block drains, the oil cooler housing has a drain cock at the extreme bottom. Radiators are drained by opening a drain cock in the bottom tank.

Marine engine exhaust manifolds are cooled by the same coolant used in the engine. Whenever the engine cooling system is drained, open the exhaust manifold drain cocks.

Raw water pumps are drained by loosening the cover attaching screws and tapping the cover gently to loosen it. After the water has drained, tighten the screws.

Flushing

If the cooling system is contaminated, flush the cooling system as follows:

1. Drain the coolant from the engine.
2. Refill with soft clean water.

NOTICE: If the engine is hot, fill *slowly* to prevent rapid cooling and distortion of the engine castings.

3. Start the engine and operate it for fifteen minutes to thoroughly circulate the water.
4. Drain the engine completely.
5. Refill with the solution required (refer to Section 13.3).

Cooling System Cleaners

If the engine overheats, and the fan belt tension and coolant level have been found to be satisfactory, it may be necessary to clean and flush the entire cooling system. Remove scale formation by using a reputable and safe de-scaling solvent. Immediately after using the de-scaling solvent, neutralize the system with the neutralizer. It is important that the directions printed on the container of the de-scaler be thoroughly read and followed.

After the solvent and neutralizer have been used, completely drain the engine and radiator and reverse flush, as outlined below, before filling the system.

Reverse Flushing

After the engine and radiator have been thoroughly cleaned, they should be reverse flushed. The water pump should be removed and the radiator and engine reverse flushed separately to prevent dirt and scale deposits clogging the radiator tubes or being forced through the pump. Reverse flushing is accomplished by hot water, under air pressure, being forced through the cooling system in a direction opposite to the normal flow of coolant, loosening and forcing scale deposits out.

The radiator is reverse flushed as follows:

1. Remove the radiator inlet and outlet hoses and replace the radiator cap.
2. Attach a hose at top of the radiator to lead water away from the engine.
3. Attach a hose to the bottom of the radiator and insert the flushing gun in the hose.
4. Connect the water hose of the gun to the water outlet and the air hose to the compressed air outlet.

5. Turn on the water and, when the radiator is full, turn on the air in short blasts, allowing the radiator to fill between air blasts.

NOTICE: Apply air gradually. Do not exert more than 30 psi (207 kPa) air pressure. Too great a pressure may rupture a radiator tube.

6. Continue flushing until only clean water is expelled from the radiator.

The cylinder block and cylinder head water passages are reverse flushed as follows:

1. Remove the thermostats and the water pump.
2. Attach a hose to the water inlet of the cylinder block to drain the water away from the engine.
3. Attach a hose to the water outlet at top of the engine and insert the flushing gun in the hose.
4. Turn on the water and, when the water jackets are filled, turn on the air in short blasts, allowing the engine to fill with water between air blasts.
5. Continue flushing until the water from the engine runs clean.

If scale deposits in the radiator cannot be removed by chemical cleaners or reverse flushing as outlined above, it may be necessary to remove the upper tank and rod out the individual radiator tubes with flat steel rods. Circulate water through the radiator core from the bottom to the top during this operation.

Miscellaneous Cooling System Checks

In addition to the above cleaning procedures, the other components of the cooling system should be checked periodically to keep the engine operating at peak efficiency. The cooling system hoses, thermostats and radiator pressure cap should be checked and replaced if found to be defective.

When water connection seals and hoses are installed, be sure the connecting parts are properly aligned and the seal or hose is in its proper position before tightening the clamps.

NOTICE: In order to assure the integrity of the cooling system, it is recommended that a periodic cooling system pressure check be performed. Pressurize the cooling system (15–20 psi or 103–138 kPa) using radiator cap and cooling system tester J 24460-01. Do not exceed 20 psi (138 kPa). Any measurable drop in pressure may indicate an external/internal leak. Whenever the oil pan is removed, the cooling system should be pressure checked as a means of identifying any incipient coolant leaks.

The fan belts must be checked and adjusted, if necessary, to provide the proper tension. The fan shroud must be tight against the radiator core to prevent recirculation of air which may lower the cooling efficiency.

Contaminated Engines

When the engine cooling or lubricating system becomes contaminated, it should be flushed thoroughly to remove the contaminants before the engine is seriously damaged. One possible cause of such contamination is a cracked oil cooler core. With a cracked oil cooler core, oil will be forced into the cooling system while the engine is operating and, when it is stopped, coolant will leak into the lubricating system.

Coolant contamination of the lubricating system is especially harmful to engines when the cooling system is filled with an ethylene glycol antifreeze solution. When mixed with the oil in the crankcase, this antifreeze forms a varnish which can cause the engine to seize or result in severe bearing wear.

Make certain that the cause of the internal coolant leak has been corrected before flushing the contaminated system(s).

Contaminants may be flushed from the engine systems as follows:

COOLING SYSTEM

If the engine has had a failure resulting in the contamination of the cooling system with lubricating oil, this flushing procedure is recommended.

1. Prepare a mixture of Calgon, or equivalent, and water at the rate of two ounces (dry measure) to one gallon of water.
2. Remove the engine thermostats to permit the Calgon and water mixture to circulate through the engine and the radiator or heat exchanger.
3. Fill the cooling system with the Calgon solution.
4. Run the engine for five minutes.
5. Drain the cooling system.
6. Repeat Steps 1 through 5.
7. Fill the cooling system with clean water.
8. Let the engine run five minutes.
9. Drain the cooling system completely.
10. Install the engine thermostats.
11. Close all of the drains and refill the cooling system with fresh coolant (Refer to Section 13.3).

LUBRICATION SYSTEM

When the engine lubricating system has been contaminated by an ethylene glycol antifreeze solution, or other water soluble material, the following cleaning procedure, using Cellosolve, or equivalent, is recommended.

CAUTION: Use extreme care in the handling of these chemicals to prevent serious injury to the person or damage to finished surfaces. Wash off spilled fluid immediately with clean water.

1. Drain all of the lubricating oil.
2. Remove and discard the oil filter elements. Clean and dry the filter shells and replace the elements.
3. Mix two parts of Cellosolve, or equivalent, with one part SAE 10 engine oil. Fill the engine crankcase to the proper operating level with the mixture.
4. Start and run the engine at a fast idle (1,000 to 1,200 rpm) for thirty minutes to one hour. Check the oil pressure frequently.
5. After the specified time, stop the engine and immediately drain the crankcase and the filters. *Sufficient time must be allowed to drain all of the fluid.*
6. Replace the drain plugs and refill the crankcase with SAE 10 oil and run the engine at the same fast idle for ten or fifteen minutes and again drain the oil thoroughly.
7. Remove and discard the oil filter elements, clean the filter shells and install new elements.
8. Replace the drains and fill the crankcase to the proper level with the oil recommended for normal engine operation.
9. To test the effectiveness of the cleaning procedure, it is recommended that the engine be started and run at a fast idle (1,000 to 1,200 rpm) for approximately thirty minutes. Then, stop and immediately restart the engine. There is a possibility that the engine is not entirely free of contaminant deposits if the starting speed is slow.
10. If the procedure for cleaning the lubricating oil system was not successful, it will be necessary to disassemble the engine and to clean the affected parts thoroughly.

Make certain that the cause of the internal coolant leak has been corrected before returning the engine to service.

MAXIMUM ENGINE COOLANT TEMPERATURE

The heat-dissipating capacity of the engine cooling systems and related components must be sufficient to prevent the coolant temperature from rising above 210°F (99°C). This temperature must not be exceeded under any

engine operating condition, regardless of altitude, type of coolant used or cooling system condition. Exceeding this limit can result in malfunction or serious engine damage.

TEMPERATURE CONTROL COMPONENTS

These engines are designed to operate with 170°F (77°C) or 180°F (82°C) thermostats which, combined with a radiator or heat exchanger, regulate coolant temperature within a range of 170°F-187°F (77-86°C) or 180-197°F (82-92°C). Many engines also use radiator shutters, clutch fans or combinations of both to help control coolant temperature. These "add on" cooling system components must operate in proper sequence to prevent coolant temperature instability and/or engine overheating.

A badly adjusted operating sequence can also have a detrimental effect on the life of the "add on" components as well.

The following charts give the recommended normal temperature settings for various coolant temperature control devices. These settings should not be exceeded, since this will unnecessarily increase the engine coolant and lubricating oil temperature, possibly resulting in serious engine damage.

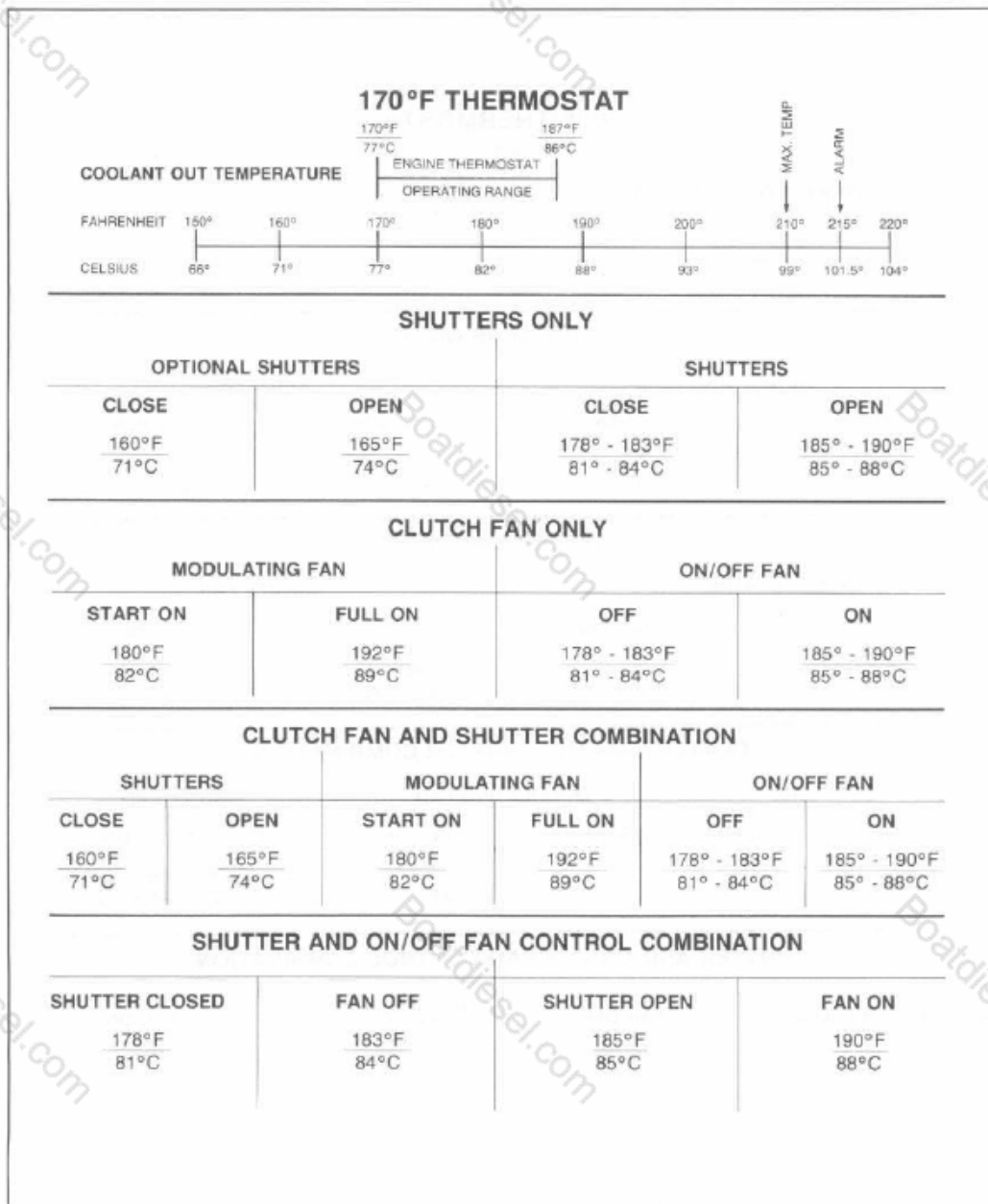
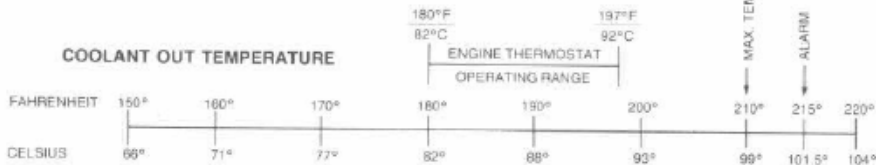

CHART 1 - 170°F Thermostat

180°F THERMOSTAT



SHUTTERS ONLY

OPTIONAL SHUTTERS		SHUTTERS	
CLOSE	OPEN	CLOSE	OPEN
170°F 77°C	175°F 79.5°C	188° - 193°F 87° - 89.5°C	195° - 200°F 90.5° - 93°C

CLUTCH FAN ONLY

MODULATING FAN		ON/OFF FAN	
START ON	FULL ON	OFF	ON
190°F 88°C	202°F 94.5°C	188° - 193°F 87° - 89.5°C	195° - 200°F 90.5° - 93°C

CLUTCH FAN AND SHUTTER COMBINATION

SHUTTERS		MODULATING FAN		ON/OFF FAN	
CLOSE	OPEN	START ON	FULL ON	OFF	ON
170°F 77°C	175°F 79.5°C	190°F 88°C	202°F 94.5°C	188° - 193°F 87° - 89.5°C	195° - 200°F 90.5° - 93°C

SHUTTER AND ON/OFF FAN CONTROL COMBINATION

SHUTTER CLOSED	FAN OFF	SHUTTER OPEN	FAN ON
188°F 87°C	193°F 89.5°C	195°F 90.5°C	200°F 93°C

CHART 2 - 180°F Thermostat

WATER PUMP

6V-92 AND 8V-92 ENGINES

The centrifugal-type water pump circulates the engine coolant through the cylinder block, cylinder heads, radiator or heat exchanger and the oil cooler (Fig. 1).

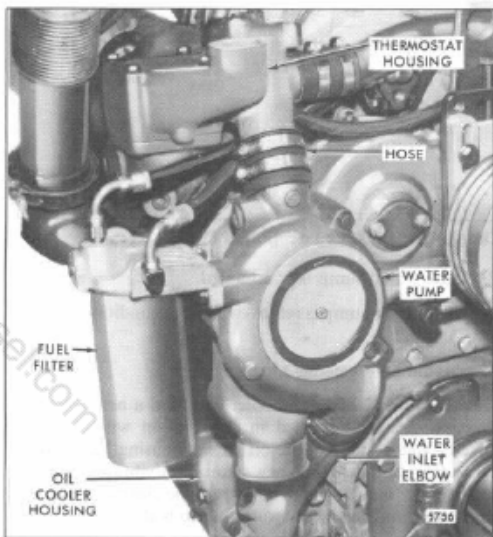

Fig. 1 - Water Pump Mounting (Former Cover with Spirolox Ring)

The pump is mounted on the engine front cover and is driven by the 66 tooth front camshaft gear (water pump drive). The water pump gear has 42 teeth and meshes with the water pump drive gear.

A bronze impeller is secured to one end of a stainless steel shaft by a locknut. The water pump gear is pressed on the opposite end of the shaft. Two ball bearings are used to carry the shaft. The larger bearing is used at the drive gear end of the shaft to accommodate the thrust load (Fig. 2 or 3).

An oil seal is located in front of the smaller bearing and a spring-loaded face type water seal is used behind the impeller.

Current engines use a higher capacity water pump which provides increased coolant circulation. The pump has a larger impeller, larger diameter inlet and outlet openings and a pump cover secured by a retaining ring.

New fresh water pumps with increased coolant flow and sealing characteristics have been released for use on engines using high-capacity pumps. The bodies of the new pumps incorporate a cast-in upper "dam" and cast-in seal cavity drain boss which act to divide incoming coolant flow and direct it more efficiently through the pump (Fig. 4). The "Y" drilled drain passage has been eliminated.

A new seal has been released for 6V 15° tilt coach engine fresh water pumps, effective with engine serial number 6VF-0103521. The new seal has a high grade carbon face, a stainless steel case and a shroud (Fig. 5). The former seal had a phenolic face, a brass case and no shroud. Because of its design, the new seal provides improved resistance to leakage even after high engine hours or mileage.

The former seal and the new seal are completely interchangeable and only the new seal will be available to service the fresh water pumps used on 6V 15° tilt coach engines.

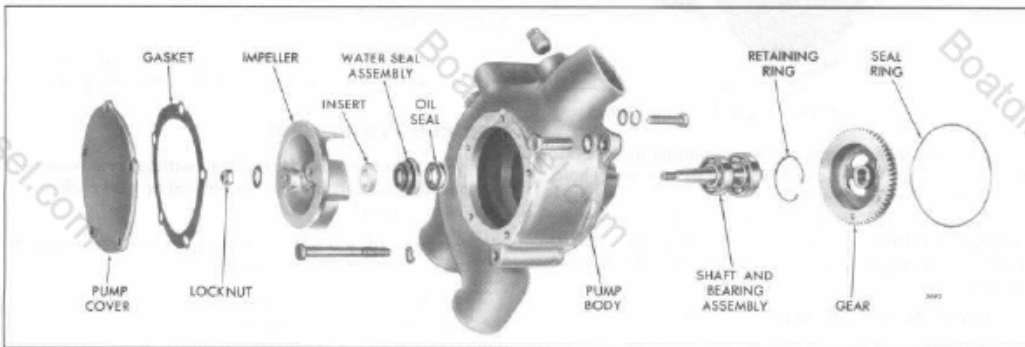

Fig. 2 - Former Water Pump Details and Relative Location of Parts

5.1 Water Pump

DETROIT DIESEL 92

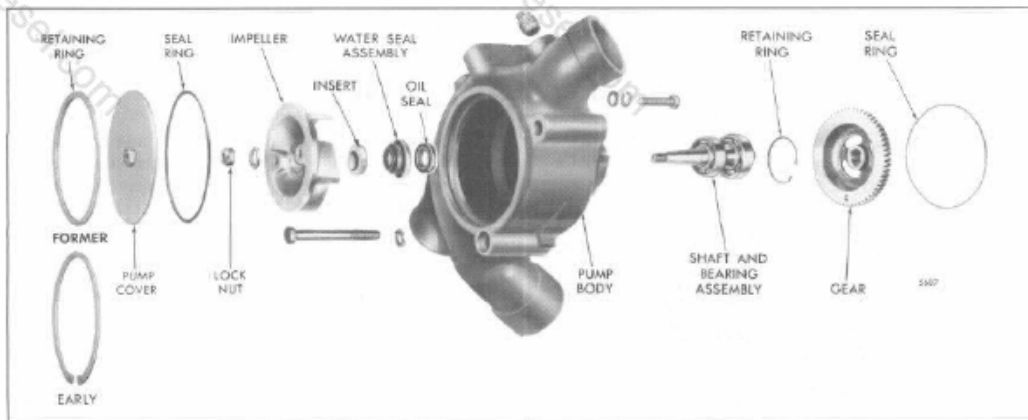

Fig. 3 – Current High-Capacity Water Pump Details and Relative Location of Parts

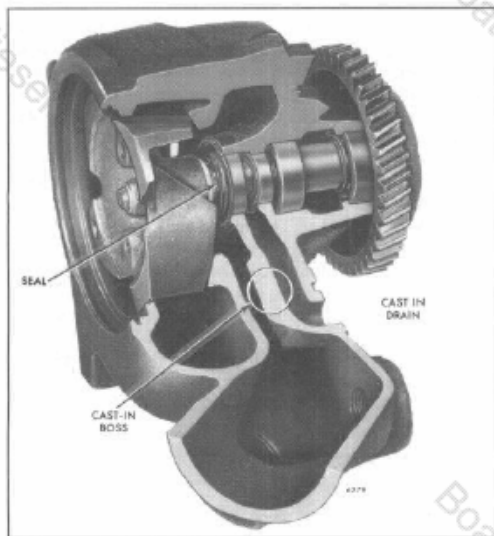

Fig. 4 – Divided Inlet High Capacity Water Pump

The former high-capacity water pumps incorporate bodies which permit the use of a large (5/16" diameter) hole, drilled straight into the bottom of the seal cavity. The early double-angle drilled drain hole has been retained for additional ventilation of the seal cavity (Fig. 6). This is effective with engine serial numbers 6VF-49834 and 8VF-46407.

Modify the early double angle drain hole (Section 5.0) when:

1. The water pump seal is replaced – 200,000 miles.

2. The water pump is overhauled.
3. The water pump is removed prior to conditions 1 and 2 above.
4. Required – passage plugged.

A 24 or 32 plate oil cooler core and a new camshaft vibration damper are used in conjunction with the high capacity water pump. The oil cooler housing has a larger diameter water inlet. The new crankshaft vibration damper has a smaller outside diameter to provide clearance between the damper and the larger water pump body.

In order to further improve the sealing of the water pump cover, a new non-metallic cover and a new scalloped retaining ring have been released (Fig. 7). The new ring is scalloped and will replace the former Spirolox ring. When used with the new ring, the new cover is completely interchangeable with the former cover and only the new cover and ring should be used to service water pumps.

Lubrication

The pump ball bearings are lubricated with oil splashed by the camshaft gear and the water pump gear.

Replace Water Seal

The water seal can be replaced without removing the pump if the radiator, fan and fan shroud or heat exchanger have been removed.

1. Remove the pump cover bolts, pump cover and gasket (Fig. 2). Discard the gasket.

On former high-capacity fresh water pumps, remove the Spirolox cover retaining ring from the groove in the pump body with a screwdriver. Remove the cover, but do not remove the seal ring.

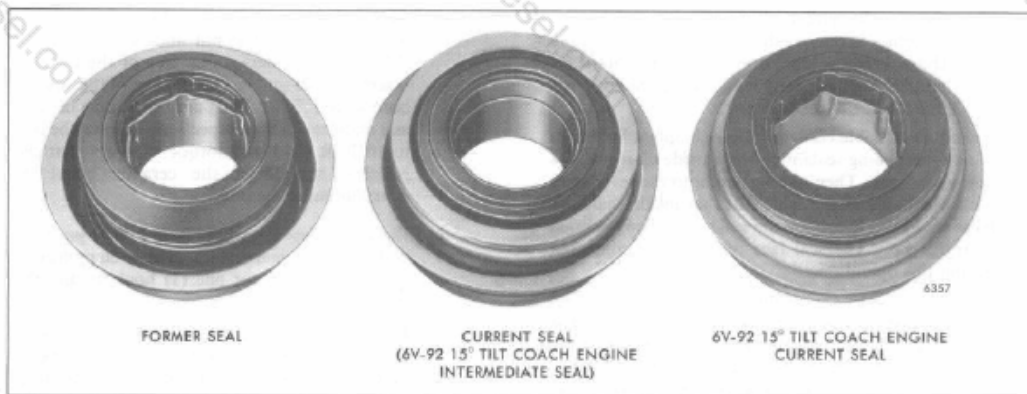

Fig. 5 - Water Pump Seals

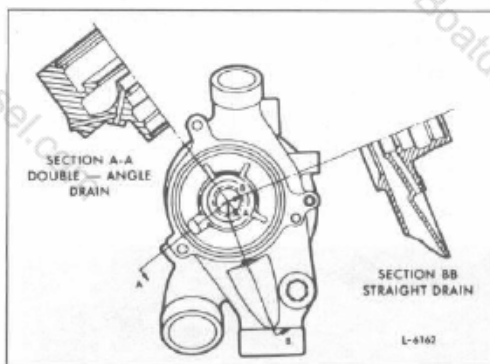

Fig. 6 - New Water Pump (6V-92 and 8V-92 Engines)

On early and current high-capacity fresh water pumps, use extreme care when removing or installing the early snap ring or the current scalloped cover retaining snap ring (Figs. 3 and 7). Remove the pump cover, but do not remove the seal ring.

CAUTION: Due to the size and tension of the ring, use snap ring pliers of a type to ensure maximum safety. Wear adequate eye protection, and press a hammer against the pump cover to help prevent personal injury should the snap ring slip off of the pliers.

The 1/4"-20 nut attached to the early and former front cover is provided to facilitate removal of the cover.

2. Remove the impeller locknut and washer and withdraw the impeller with puller J 24420-A.
3. On current seals use a channel lock type pliers to grasp the metal flange around the upper portion of the seal

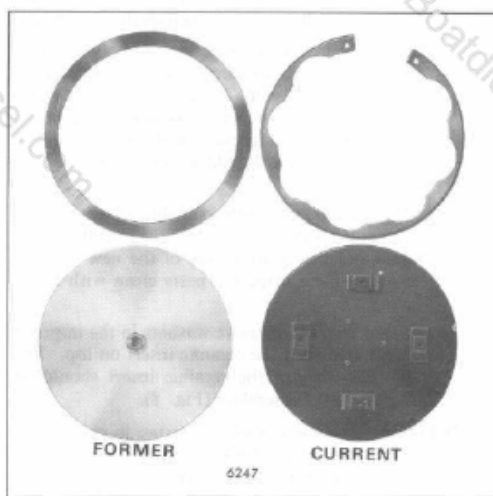

Fig. 7 - Cover and Retaining Ring (Former and Current)

and twist it firmly so as to break the seal and boot assembly away from the case. Use care to avoid damaging the pump shaft during this operation.

4. Install the seal removal tool (J 22150-B) in the pump and secure it in place with the pump cover snap ring or bolts or retaining nuts. On the 6V and 8V high-capacity water pump, the cover seal ring should be left in place to avoid damage to the seal ring groove.

- a. Turn the puller shaft nut (J 22150-4) in a counterclockwise direction until the spears pierce the water seal case. Then, turn the puller shaft in a clockwise direction one eighth of a turn to lock the spears in place.

5.1 Water Pump

DETROIT DIESEL 92

- b. Rotate the puller shaft nut in a clockwise direction to remove the water seal. Disassembly the seal removal tool from the pump. On the 6V and 8V high-capacity water pump, remove and discard the cover seal ring.
5. To reduce possible coolant leakage, apply a light coat of non-hardening sealant on the outside diameter of a new water seal. Then, tap the seal into the seal cavity with a suitable sleeve which has an inside diameter large enough to fit around the seal and rest on the brass cartridge lip. The seal face must not be contacted during this operation.
6. Inspect the water pump impeller for wear (erosion) and reuse or replace, as required. If the impeller is reused, the ceramic impeller insert *must* be replaced. Never attempt to reuse the ceramic insert, regardless of its apparent condition. A worn ceramic insert may leak. Always replace the insert or impeller assembly (with insert) at time of water pump overhaul. Bond a new ceramic impeller insert to the impeller, as follows:
 - a. Bake the insert and impeller assembly at 500°F (260°C) for 90 minutes. The insert can be removed easily while the adhesive is hot. After removing the insert, clean the insert area on the impeller with sandpaper, wire brush or a buffing wheel to remove the old adhesive, oxide, scale, etc.
 - b. Wet a clean cloth with a suitable solvent such as alcohol and thoroughly clean the impeller insert area and the grooved side of the new ceramic insert. Then, wipe the parts clean with a dry cloth.
 - c. Place Two (2) adhesive washers in the impeller bond area with the ceramic insert on top. The polished face of the ceramic insert should be visible to the assembler (Fig. 8).

NOTICE: Adhesive washers are tan in color but have a white paper backing which *must* be removed and discarded before the washers can be used. Failure to remove the paper backing will result in a weak or ineffective bond between the insert and impeller.

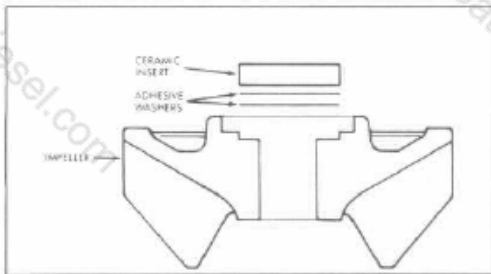

Fig. 8 - Insert, Adhesive Washer, Impeller Stackup

Clamp the ceramic insert and impeller together with a 3/8" bolt and nut and two (2) smooth .125" thick washers. The face of the ceramic insert must be square with the axis of the tapered bore within .004". The pump shaft may be used as a mandrel for this inspection. Tighten the bolt to 10 lb-ft (14 Nm) torque. Do not mar the polished surface of the ceramic insert by overtightening the bolt.

- d. Place the impeller assembly in a level position, with the ceramic insert up, in an oven preheated to 350°F (177°C) for one (1) hour to cure the adhesive.
- e. Remove the impeller from the oven and, after it has cooled to room temperature, install it in the pump. Do not loosen or remove the clamping bolt and washers until the assembly cools.
7. Make sure the mating surfaces of the water seal and the ceramic insert are free of dirt, metal particles and oil film (Fig. 2).
8. Apply a small quantity of International Compound No. 2, or equivalent, to the threads of the pump shaft.
9. Place the impeller and washer on the shaft and start a new locknut on the shaft. Hold the pump gear securely while drawing the impeller down on the tapered shaft with the locknut. Tighten the nut to 35-40 lb-ft (47-54 Nm) torque.

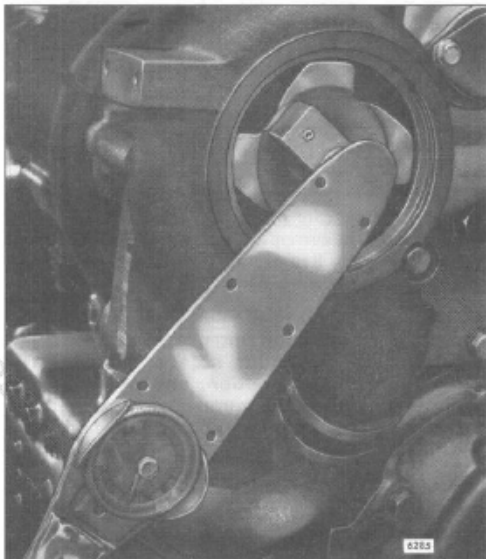

Fig. 9 - Checking Impeller and Gear Slip Torque with Tool J 33765

10. Check the water pump impeller and gear *slip torque*, as follows (Fig. 9):
 - a. Scribe a line across the impeller, nut and shaft.
 - b. Attach adaptor J 33765 to an accurately calibrated torque wrench.
 - c. Insert the dowel pins of the adaptor into the impeller puller holes and apply a torque of 80 lb-ft (108 N•m). Some slight movement of the crankshaft may be detected during this operation until the next cylinder in the firing order comes up on compression.
 - d. If slippage is felt, examine the marks scribed across the impeller and shaft. If the marks are no longer in alignment, the impeller has turned on the shaft. If the marks are still in alignment, the gear has turned on the shaft. In either case, remove the pump from the engine.
 - e. Replace the shaft, along with either the gear or impeller that has turned on the shaft, and bench test the completed pump assembly. (Refer to *Assembly Pump*).
11. Loosen the clamps and remove the hose from the water outlet opening of the pump.
12. Insert a feeler gage into the water outlet opening of the pump. The minimum clearance between the impeller and the pump body must be .015".
13. Use a new gasket and install the former water pump cover. The water pump cover on former pumps is secured by cadmium plated bolts with nylon inserts to prevent water leakage. Inspect them carefully to make sure the nylon inserts are in place and protrude sufficiently beyond the threads. *Under no circumstances should a standard bolt be used.* Tighten the nuts or bolts securely.

Install the water pump cover and retaining ring, as follows (Fig. 3):

- a. Remove the seal ring and clean the seal ring groove of any rust or pitting.
- b. Install a new seal "O" ring in the seal ring groove in the pump body.
- c. Install the water pump cover making sure the seal ring is properly seated in the groove.
- d. Spread the end of the retaining ring and feed it into the retaining groove in the pump body, proceeding in a clockwise direction until both layers are completely into the groove.
- e. With a plastic or wooden mallet strike the pump cover at the 12:00, 9:00, 6:00 and 3:00 o'clock positions. This will allow the retaining ring to spread into the groove. Repeat the operation several times.

- f. Now strike the retaining ring outward (with the plastic or wooden mallet) starting with the visible end of the ring and proceeding in a counterclockwise direction. Strike around the circumference of the ring 2 or 3 times until the ring fully seats in the groove. The retaining ring is fully seated when 3/16" or less of the ring, measured radially, is visible.

14. Install and secure the hose on the water outlet opening with the clamps.

Remove Pump

1. Refer to Section 5 and drain the cooling system.
2. Remove the radiator, fan shroud and fan or heat exchanger, if necessary.
3. Loosen the hose clamps and remove the hoses from the pump body.
4. Remove the pump body-to-engine front cover mounting bolts and detach the pump. Use care to prevent damage to the gear teeth when disengaging the pump gear from the front camshaft gear (water pump drive gear).

Disassemble Pump

1. Turn the pump gear so the slot is over the ends of the bearing retaining ring, insert pliers J 4646 into the slot and, with the aid of a small screwdriver, remove the ring from the groove (Fig. 10).

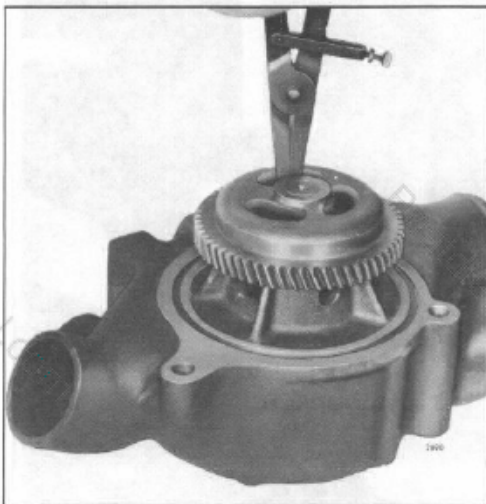

Fig. 10 - Removing Retaining Ring using Tool J 4646

5.1 Water Pump

DETROIT DIESEL 92

2. Remove the pump cover, as outlined in *Replace Water Seal*.
3. Hold the gear securely and remove the impeller locknut and washer.

NOTICE: While holding the gear, use care to prevent damage to the gear teeth.

4. Use puller J 24420-A to remove the impeller.
5. Press the shaft, bearings and pump gear assembly out of the pump body.
6. Place the gear on the bed of an arbor press with the shaft extending downward, then place a short piece of .625" diameter bar stock between the shaft and the ram of the press and press the shaft out of the gear (Fig. 11).
7. Support the shaft assembly on the inner race of the larger bearing with the threaded end down. Place flat stock between the ram of the press and the shaft and press the pump shaft out of the large bearing.
8. Invert the shaft, support it on the inner race of the small bearing and repeat the process described in Step 7.
9. If necessary, remove the water seal as described under *Replace Water Seal*.
10. Push the oil seal out of the pump body.

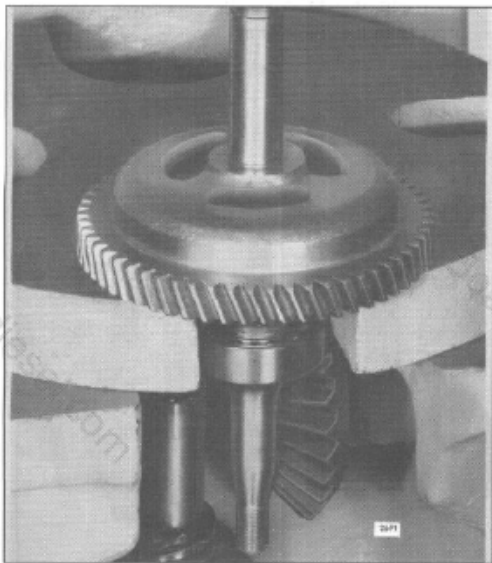

Fig. 11 - Pressing Shaft Out of Gear

New seals and a new ceramic impeller insert must be used each time the water and oil seals are removed or at water pump overhaul.

Inspection

Wash all of the pump parts in clean fuel oil and dry them with compressed air.

CAUTION: To prevent possible personal injury, wear adequate eye protection and do not exceed 40 psi (276 kPa) air pressure.

Inspect parts for cracks, wear or other damage. Replace damaged or worn parts. A new ceramic insert must be used. Refer to *Replace Water Seal*.

Make sure the drilled "Y" passage in the pump body is clear of any obstruction. Use the following procedure.

1. Mount a spring from a front crankshaft seal or an equivalent tool into a 1/4" drill motor.
2. Mark the spring with tape at 3 3/4" from the end.

NOTICE: The measurements given in Steps 2 and 3 do not include the installed length of the 5/16" O.D. tube in the modified pumps. Add tube protrusion measurement to these dimensions (3 3/4" and 2 9/16").

3. Insert the spring into the drain hole and drill. At 2 9/16" into the passage, some resistance will be felt as the spring negotiates the corner of an intersecting passage. If the spring cannot be inserted to the 3 3/4" depth, the passage must be cleaned and modified using the "modification procedure" (see Section 5.0).

NOTICE: The drain hole cleaning procedure just outlined should be continued after the 200,000 mile seal replacement interval is reached and/or the water pump is disassembled and modified.

The bearings should be examined for corrosion, pitting, wear and freedom of movement. Apply engine oil to the bearings, hold the inner race and slowly revolve the outer race to check for roughness. Replace the bearings, if necessary. When replacing an inner or outer bearing always replace the other bearing.

Assemble Pump

1. Lubricate the bearing bores and shaft bearing surfaces. Use bearing and gear installer J 25257 and install the bearings on the shaft (Fig. 12). Apply pressure to the inner races of the bearings only during assembly on the shaft.

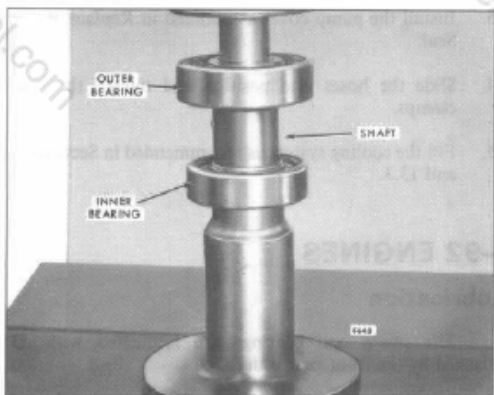

Fig. 12 - Pressing Bearing on Pump Shaft using Tool J 25257

2. Apply a film of engine oil to the sealing lip of the oil seal and the lip contact surface of the shaft. Then, insert the seal, spring loaded lip toward the gear end of the pump body. With Tool J 8501 (oil seal installer), tap the seal into place. The oil seal must be flush with the water seal counterbore in the pump body.
3. Support the pump body on the bed of an arbor press with the cover side down. Then, press the shaft and bearing assembly in place by applying pressure on the outer race of the large bearing. Take care not to damage the oil seal with the threaded end of the shaft.
4. Install the bearing retaining ring.
5. With gear installer J 25257 positioned on the impeller end of the shaft, place the gear between the shaft and the ram of the press (Fig. 13). Press the gear on the shaft so it is flush with the end of the shaft. Tool J 25257 will hold the shaft vertically to ensure the gear is pressed squarely on the shaft.

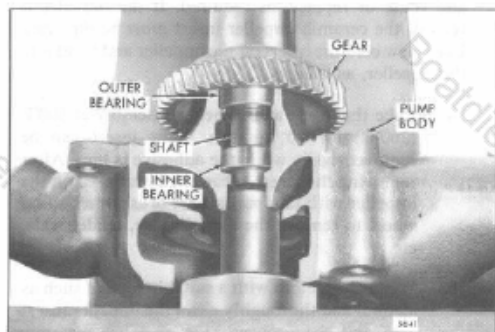

Fig. 13 - Pressing Gear on Pump Shaft using Tool J 25257

6. Place the pump body on the bed of an arbor press. To prevent possible coolant leakage, apply a light coat of non-hardening sealant on the outside diameter of a new water seal. Then, insert the seal in the cavity in the pump body and, with a sleeve large enough to fit around the seal and resting on the brass cartridge lip, press the seal into place.
7. Make sure the mating surfaces of the water seal and the ceramic insert are free of dirt, metal particles and oil film.
8. Apply a small quantity of International Compound No. 2, or equivalent, to the threads of the pump shaft.
9. Place the impeller washer and new locknut on the shaft. Hold the pump gear securely while drawing the impeller down on the tapered shaft with the locknut. Tighten the nut to 35-40 lb-ft (47-54 N•m) torque.

NOTICE: Do not damage the gear teeth while holding the gear.

10. Check the water pump impeller and gear *slip torque*, as follows:
 - a. Scribe a line across the water pump gear and shaft.
 - b. Scribe a second line across the impeller, nut and shaft.
 - c. Attach adaptor J 33765 onto an accurately calibrated torque wrench.
 - d. With the water pump drive gear securely held in the brass jaws of a vise, insert the adaptor dowel pins into the impeller puller holes and apply a torque of 80 lb-ft (108 N•m).
 - e. If slippage is felt, remove the pump from the vise and examine the scribed marks. Determine whether the gear or the impeller has turned on the shaft. In either case the shaft must be replaced, along with the component that has turned.
 - f. After replacing the necessary parts, retest the completed pump assembly.
11. Insert a feeler gage into the water outlet opening of the pump. The clearance between the impeller and the water pump body must be .015" minimum.
12. Install the hose on the water outlet opening and secure it with clamps.

Install Pump On Engine

1. Affix the seal ring to the pump body. Mount the pump on the engine so the pump gear meshes with the camshaft gear. Install and tighten the mounting bolts.

2. Check the gear backlash by installing bolts, or equivalent, in the impeller puller holes. Measure the backlash with an indicator at that point. The gear backlash setting should be .001" to .006" when measured in this manner. When the specified backlash reading cannot be obtained, loosen the pump attaching bolts and pivot the pump at the dowel as required to obtain the proper lash adjustment. Retighten the mounting bolts.
3. Install the pump cover as outlined in *Replace Water Seal*.
4. Slide the hoses into position and tighten the hose clamps.
5. Fill the cooling system as recommended in Sections 5 and 13.3.

12V-92 AND 16V-92 ENGINES

The centrifugal-type water pump is mounted on the front engine cover and is driven by the right front camshaft gear (water pump drive) - (Fig. 14). The pump circulates engine coolant through the cylinder block, cylinder heads, radiator or heat exchanger and the oil cooler.

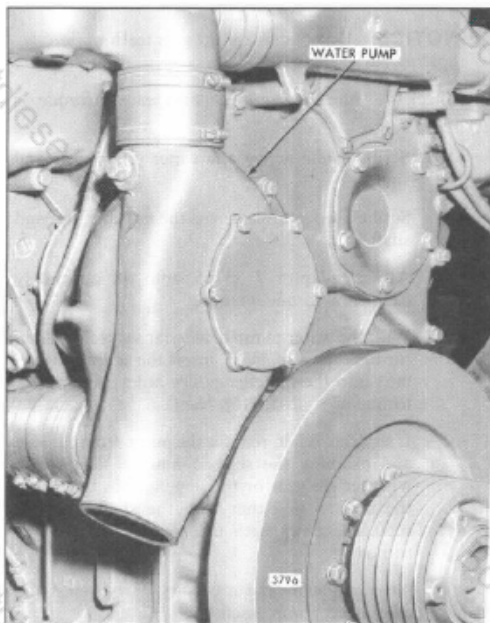

Fig. 14 - Water Pump Mounting (12V-92 and 16V-92 Engine)

The pump consists of a bronze impeller secured to a stainless steel shaft with a locknut. A gear is pressed on the opposite end of the shaft and the shaft turns on two ball bearings which are supported in a bearing and water and oil seal container. The container is secured to the pump housing with nuts and washers on studs installed in the pump body. An oil seal is used ahead of the front bearing and a spring-loaded face type water seal is used in back of the impeller.

Lubrication

The pump ball bearings are lubricated with oil splashed by the front gear train.

Replace Water Seal Assembly

The water seal assembly may be replaced without removing the pump if the fan, fan shroud and radiator or heat exchanger have been removed.

1. Remove the pump cover, gasket and deflector ring (Fig. 15).
2. Loosen and remove the impeller locknut and washer. Use puller J 24420-A to withdraw the impeller.
3. Grasp the water seal assembly with suitable pliers and pull the seal out of the retainer.
4. To reduce possible coolant leakage, apply a light coat of non-hardening sealant on the outside diameter of a new water seal. Then, tap the seal in the seal cavity with a suitable sleeve, with an inside diameter large enough to fit around the seal and rest on the brass cartridge lip.
5. Inspect the water pump impeller for wear (erosion) and reuse or replace, as required. If the impeller is reused, the ceramic impeller insert *must* be replaced. Use a new ceramic insert on the impeller and bond it to the impeller, as follows:
 - a. Bake the insert and impeller assembly at 500°F (260°C) for 90 minutes. The insert can be removed easily while the adhesive is hot. After removing the insert, clean the insert area on the impeller with sandpaper, wire brush or a buffing wheel to remove the old adhesive, oxide, scale, etc.
 - b. Wet a clean cloth with a suitable solvent such as alcohol and thoroughly clean the impeller insert area and the grooved side of a new ceramic insert. Then, wipe the parts with a clean dry cloth.

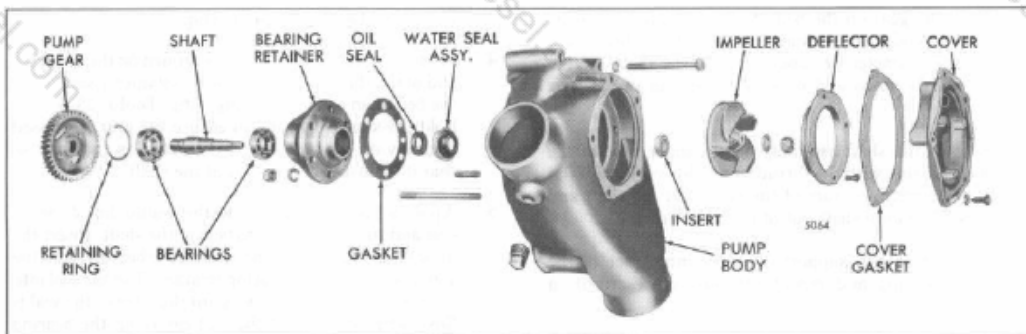

Fig. 15 - Water Pump Details and Relative Location of Parts

- c. Place the adhesive washer in the impeller bond area with the ceramic insert on top. The polished face of the ceramic insert should be visible to the assembler (Fig. 8).

Clamp the ceramic insert and impeller together with a 3/8" bolt and nut and two smooth .125" thick washers. Tighten the bolt to 10 lb-ft (14 N•m) torque.

NOTICE: Do not mar the polished surface of the ceramic insert.

- d. Place the impeller assembly in a level position, with the ceramic insert up, in an oven preheated to 350°F (177°C) for one hour. The face of the ceramic insert must be square with the axis of the tapered bore within .004". The pump shaft may be used as a mandrel for this inspection.
- e. Remove the impeller from the oven and, after it has cooled to room temperature, install it in the pump. Do not loosen and remove the clamping bolt and washers until the assembly cools.
6. Make sure the mating surfaces of the water seal assembly and the ceramic insert are free of dirt, metal particles and oil film (Fig. 15).
7. Apply a small quantity of International Compound No. 2, or equivalent, to the threads of the pump shaft.
8. Place the impeller and washer on the shaft and start a new locknut on the shaft. Hold the pump gear securely while drawing the impeller down on the tapered shaft with the locknut. Tighten the nut to 35-40 lb-ft (47-54 N•m) torque.
9. Secure the impeller deflector ring to the pump body. Be sure the four 1/4"-20 x 5/8" screws are staked securely at three places.
10. Affix a new gasket and install the pump cover. Tighten the nuts securely.

Remove Pump

1. Drain the engine cooling system (Section 5).
2. If necessary, remove the radiator, fan shroud and fan or heat exchanger.
3. Remove the pump cover.
4. Loosen the hose clamps and remove the hoses.
5. Remove the nuts and lock washers from the rear bearing support cover-to-end plate studs, then remove the bolts and copper washers.
6. Grasp the pump firmly and remove the two pump body to engine front cover bolts and lock washers. Use caution to prevent damage to the gear teeth and detach the water pump.

Disassemble Pump

1. Remove the impeller deflector ring.
2. Turn the pump gear so the slot is over the ends of the bearing retaining ring, insert pliers J 4646 into the slot and, with the aid of a small screwdriver, remove the ring from the groove (Fig. 10).
3. Hold the gear securely and remove the impeller locknut and washer.

NOTICE: While holding the gear, use care to prevent damage to the gear teeth.

4. Use puller J 24420-A to remove the impeller.
5. Remove the bearing retainer from the pump body.
6. While supporting the bearing and seal retainer, tap the threaded end of the shaft lightly with a soft hammer to separate the shaft and bearing assembly from the retainer.

5.1 Water Pump

DETROIT DIESEL 92

7. Place the gear on the bed of an arbor press with the shaft extending downward. Then, place a short piece of .625" diameter bar stock between the shaft and the ram of the press and press the shaft out of the gear (Fig. 11).
8. Support the shaft assembly on the inner race of the large bearing with the threaded end down. Place a flat plate between the ram of the press and the shaft and press the pump shaft out of the large bearing.
9. Invert the shaft, support it on the inner race of the small bearing and repeat the process described in Step 7.
10. The water seal may be pryed out of the bearing retainer with a screwdriver, if necessary.
11. Push the oil seal out of the retainer.

New seals and a new ceramic impeller insert must be used each time the water and oil seals are removed or at water pump overhaul.

Inspection

Wash all of the pump parts in clean fuel oil and dry the parts with compressed air.

CAUTION: To prevent possible personal injury, wear adequate eye protection and do not exceed 40 psi (276 kPa) air pressure.

Inspect them for cracks, damage or wear. Replace damaged or worn parts. A new ceramic insert must be used. Refer to *Replace Water Seal Assembly*.

The bearings should be examined for corrosion, pitting, wear and freedom of movement. Apply engine oil to the bearings. Hold the inner race and slowly revolve the outer race to check for roughness. Replace the bearings, if necessary.

Assemble Water Pump

1. Lubricate the bearing bores and shaft bearing surfaces. Use bearing and gear installer J 25257 and press the bearings against the shoulders on the shaft (Fig. 12). Apply pressure to the inner races of the bearing only during assembly on the shaft.
2. Support the bearing retainer on the bed of an arbor press, water seal end down. Then, press the shaft and bearing assembly into the retainer. Apply pressure to the outer race of the large bearing when installing the shaft and bearing assembly in the retainer.

3. Install the bearing retaining ring.
4. With gear installer J 25257 positioned on the threaded end of the shaft, place the bearing retainer assembly on the bed of an arbor press (Fig. 16). Tool J 25257 will hold the shaft vertically to ensure the gear is pressed squarely on the shaft. Press the gear on the shaft so that it is flush with the end of the shaft.
5. Apply a film of engine oil to the sealing lip of the oil seal and the lip contact surface of the shaft. Insert the oil seal, spring loaded lip towards the bearing, into the water seal end of the bearing retainer. Tap the seal into place with a suitable sleeve until the edge of the seal is flush with the edge of the seal cavity on the bearing side.
6. To reduce possible coolant leakage, apply a light coat of non-hardening sealant to the outside diameter of a new water seal. Then, press the seal in place with a suitable sleeve, with an inside diameter large enough to fit around the seal and resting on the brass cartridge lip (Fig. 17).
7. Make sure the mating surfaces of the water seal and the ceramic insert are free of dirt, metal particles and oil film.
8. Affix a new gasket and install the bearing retainer with six lock washers and nuts. Tighten the nut.
9. Apply a small quantity of International Compound No. 2, or equivalent, to the threads of the pump shaft.

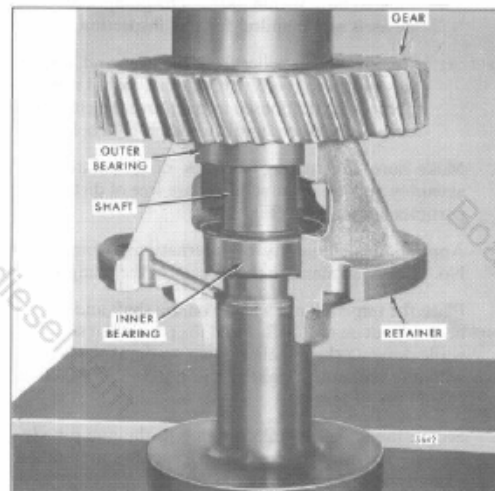

Fig. 16 - Pressing Gear on 12V-92 and 16V-92 Water Pump Shaft using Tool J 25257

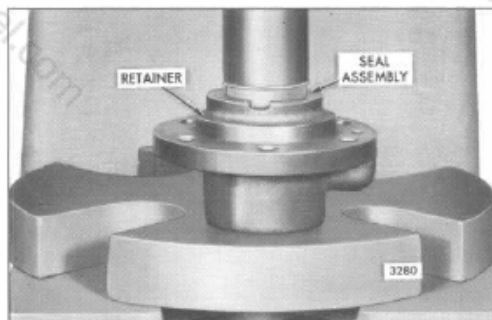

Fig. 17 – Installing Water Seal Assembly

10. Install the impeller and washer on the shaft and start a new locknut on the shaft. Hold the gear securely while drawing the impeller down on the tapered shaft with the locknut. Tighten the nut to 35–40 lb-ft (47–54 Nm) torque.

NOTICE: Do not damage the gear teeth while holding the gear.

11. Secure the impeller deflector ring to the pump body. Be sure the four 1/4"-20 x 5/8" screws are staked securely at three places.

Install Water Pump On Engine

1. Place a new gasket on the pump body.
2. Position the pump and slide the long studs into the holes in the front cover. Make sure the pump gear and camshaft gear teeth are engaged correctly.
3. Install the pump body-to-engine front cover bolts and lock washers.
4. Secure the nuts and lock washers on the water pump body studs that extend through the front cover. Then, install the two (2) bolts and lock washers from the back side of the end plate.
5. Replace the hoses and secure them with clamps.
6. Check the gear backlash (clearance) between the water pump gear and the camshaft gear by installing bolts, or equivalent, in the impeller puller holes and measuring the lash with an indicator at that point. The gear lash setting should be .001" to .006" when measured in this manner.
7. Install the water pump cover and a new gasket on the water pump. Position the cover, as indicated by the word "TOP" which is cast on the cover.
8. Replace all of the engine parts which were removed to facilitate pump removal.
9. Refill the cooling system, as recommended in Sections 5 and 13.3.

WATER MANIFOLD

The 6 and 8V engines do not require external water manifolds. All 12 and 16V engines are equipped with external water manifolds (one per cylinder head).

Coolant, leaving the cylinder head through an opening directly over each exhaust port, enters the water manifold which is attached to the cylinder head with two studs, lock washers and nuts at each of the water openings. A separate gasket is used at each attaching flange between the manifold and cylinder head.

A four-leg manifold has replaced the former six-leg manifold. Only the new manifold will be serviced. The reduction of two legs has no detrimental effect upon engine cooling. However, when replacing the old manifold by the new, two plates, gaskets and four 3/8"-16 x .88" bolts to seal the unused openings in the cylinder head must be added. Tighten these bolts to 20-25 lb-ft (27-34 Nm) torque.

Remove Water Manifold

1. Drain the cooling system, to the level necessary, by opening the cylinder block drain cocks.

CAUTION: To avoid being burned by the hot liquid, allow the engine to cool before draining the coolant.

2. Loosen the seal clamp at the front end of the water manifold. Then slide the seal over the neck of the thermostat housing or the water manifold.
3. Remove the water manifold attaching nuts and lock washers and lift the manifold off of the cylinder head.
4. Remove and discard the water manifold gaskets.

Install Water Manifold

1. Install new water manifold gaskets.
2. Attach the water manifold to the cylinder head with the lock washers and nuts. Tighten the nuts to 20-25 lb-ft (27-34 Nm) torque.
3. Slide the seal onto the outlet end of the water manifold and secure the seal with the clamp.
4. Fill the cooling system to the proper level.

THERMOSTAT

The temperature of the engine coolant is automatically controlled by a thermostat located in a housing attached to the water outlet end of each cylinder head. Blocking type thermostats (Fig. 1 or 3) are used when a standard cooling system is employed; semi-blocking type thermostats (Fig. 2) are used with the rapid warm-up cooling system. Two thermostats are employed in 6 and 8V engines; four thermostats are used in the 12 and 16V engines.

Operation

At coolant temperatures below 160°–180°F (71°–82°C) depending upon the thermostat used – the valves remain closed and block the flow of coolant to the radiator. During this period, all of the coolant in the standard system is circulated through the engine and is directed back to the suction side of the water pump via the bypass tube. In the rapid warm-up system enough coolant to vent the system is bypassed to the radiator top tank by means of a separate external deaeration line and then back to the water pump without going through the radiator cores. As the coolant temperature rises above 160°–180°F (71°–82°C), the thermostat valves start to open, restricting the bypass system, and permit a portion of the coolant to circulate through the radiator. When the coolant temperature reaches approximately 185°–197°F (85°–92°C) the thermostat valves are fully open, the bypass system is completely blocked off and all of the coolant is directed through the radiator.

NOTICE: Engines using shutters and equipped with 180°–197°F (82°–92°C) thermostats may have an effect on the operation of the shutters.

A defective thermostat which remains closed, or only partially open, will restrict the flow of coolant and cause the engine to overheat. A thermostat which is stuck in a full open position may not permit the engine to reach its normal operating temperature. The incomplete combustion of fuel due to cold engine operation will result in excessive carbon deposits on the pistons, rings and valves.

Properly operating thermostats are essential for efficient operation of the engine. If the engine operating temperature deviates from the normal range of 160°–197°F (71°–92°C), the thermostats should be removed and checked.

NOTICE: There are areas where approved fuel (less than 0.5% sulfur) is not commercially available or economically feasible to obtain. It is important to keep the engine cooling system temperature of these engines on the high side of

normal to prevent the condensation of sulfur trioxide gas, which combines with combustion water to form sulfuric acid. Therefore, install a 180° or 190° F (82° or 88° C) temperature thermostat and modify the cooling system to provide rapid warm-up in order to maintain coolant temperature at a minimum of 175° F (80°C).

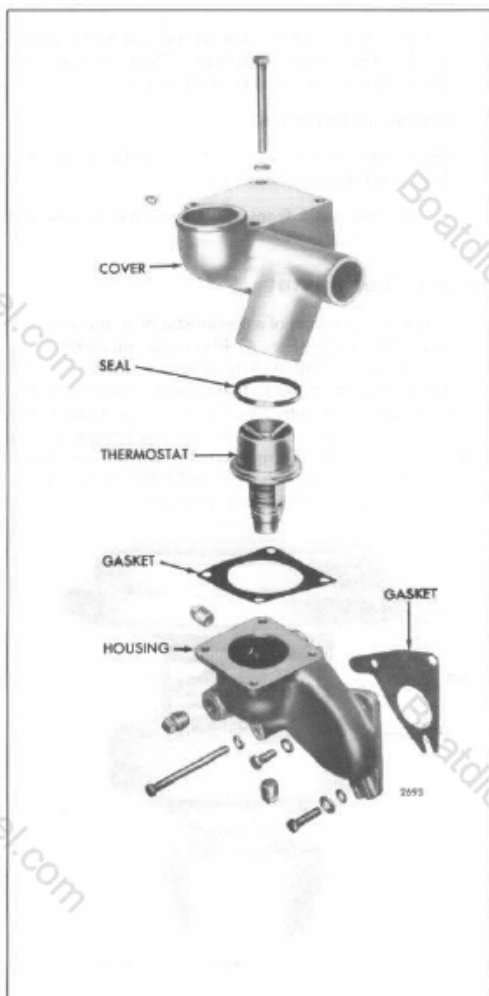

Fig. 1 - Typical Thermostat Housing and Relative Location of Parts

5.2.1 Thermostat

DETROIT DIESEL 92

Remove Thermostat

Refer to Fig. 1 and remove the thermostats as follows:

1. Drain the cooling system to the necessary level by opening the drain cocks, or removing the drain plugs on the cylinder block.
2. Loosen the hose connections and remove the bypass (cross-over) tube. Then loosen the hose connections between the water pump and the right bank thermostat housing cover.
3. Remove the bolts and lock washers securing the covers to the thermostat housings. Then remove the thermostat housing covers and gaskets.
4. Remove the thermostats.
5. Clean the thermostat seating surfaces in the thermostat housings and covers.
6. Remove the seals from the thermostat covers and discard the seals.

Inspect Thermostat

Check the operation of a thermostat by immersing it in a container of hot water (Fig. 4). Place a thermometer in the container, but do not allow it to touch the bottom of the container. Agitate the water to maintain an even temperature throughout the container. As the water is heated, the thermostat should begin to open (the opening temperature is usually stamped on the thermostat). The thermostat should be fully open at approximately 185°-197°F (85°-92°C). Allow at least 10 minutes for thermostat to react.

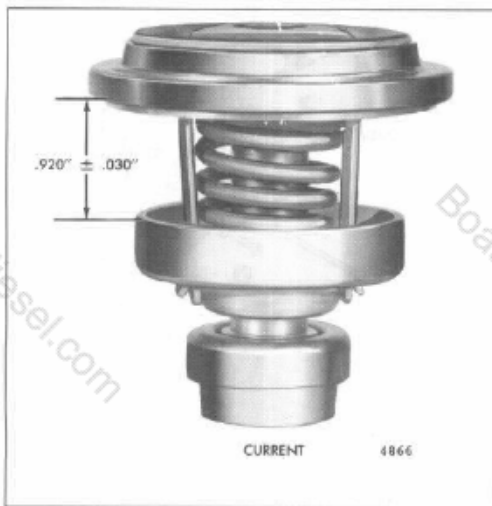

Fig. 2 - Semi-Blocking (Shielded) Type Thermostat

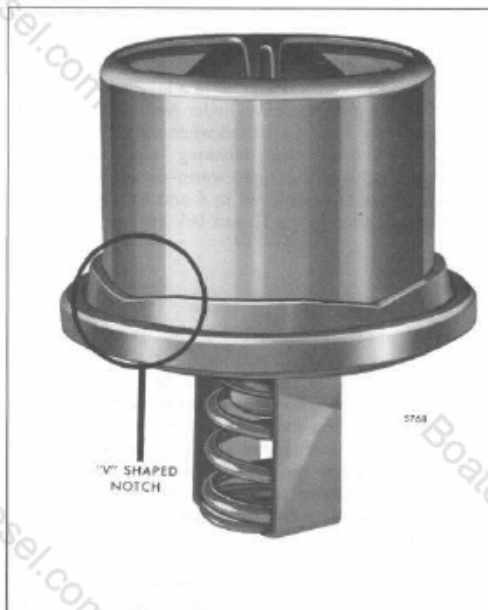

Fig. 3 - Weir Type Thermostat

Install Thermostat

1. Install new seals in the thermostat housing cover with installer J 8550 and driver handle J 7079-2. Position the seal so that the lip of the seal faces up (away from the thermostat) when the cover is installed on the thermostat housing. The seal installing tool assures that the seal is positioned the correct distance from the bottom face of the cover and parallel with the cover face.
2. Place a new gasket on the thermostat housing.
3. Set the thermostats in the thermostat housing.
4. Attach the covers to the thermostat housings with bolts and lock washers. Tighten the 3/8"-16 bolts to 30-35 lb-ft (41-47 Nm) torque.
5. Slide the hose in place between the water pump and the right bank thermostat housing cover. Tighten the clamps.
6. Install the bypass (cross-over) tube and tighten the hose clamps.
7. Close the drain cocks in the cylinder block. Then fill the cooling system.
8. Start the engine and check for leaks.

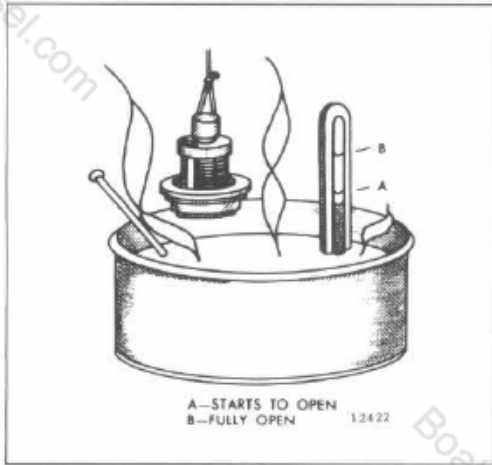

Fig. 4 - Method of Checking Thermostat Operation

RADIATOR

On some engines, the temperature of the coolant circulating through the engine is lowered by the action of the radiator and the fan. The radiator is mounted in front of the engine so that the fan will draw air through it, thereby lowering and maintaining the coolant temperature to the degree necessary for efficient engine operation.

To prolong the life of the radiator, refer to Section 13.3 for the recommended type of coolant.

To increase the cooling efficiency of the radiator, a metal shroud is placed around the fan. The fan shroud must be fitted airtight against the radiator to prevent re-circulation of the hot air drawn through the radiator. Hot air which is permitted to pass around the sides or bottom of the radiator and is again drawn through the radiator will cause overheating of the engine.

Another cause of overheating is slippage of the fan drive belts which is caused by incorrect belt tension, worn belts or worn fan belt pulley grooves, or the use of fan belts of unequal length when two or more belts are used. The belt tension and condition of the belts should be checked periodically as outlined in Section 15.1.

A radiator that has a dirty, obstructed core or is leaking, a leak in the cooling system, or an inoperative thermostat will also cause the engine to overheat. The radiator must be cleaned, the leaks eliminated, and defective thermostats replaced immediately to prevent serious damage from overheating.

The external cleanliness of the radiator should be checked if the engine overheats and no other causes are apparent.

Cleaning Radiator

The radiator should be cleaned whenever the foreign deposits are sufficient to hinder the flow of air or the transfer of heat to the air. In a hot, dusty area, periodic cleaning of the radiator will prevent a decrease in efficiency and add life to the engine.

The fan shroud and grill should be removed, if possible, to facilitate cleaning of the radiator core.

An air hose with a suitable nozzle is often sufficient to remove loose dust from the radiator core.

CAUTION: To prevent possible personal injury, wear adequate eye protection and do not exceed 40 psi (276 kPa) air pressure.

Occasionally, however, oil may be present requiring the use of a solvent, such as mineral spirits, to loosen the dirt. The use of gasoline, kerosene, or fuel oil is NOT

recommended as a solvent. A spray gun is an effective means of applying the solvent to the radiator core. Use air to remove the remaining dirt. To avoid damage to the radiator fins, do not use high air or water pressure. Repeat this process as many times as necessary, then rinse the radiator with clean water and dry it with air.

CAUTION: Provide adequate ventilation of the working area to avoid possible toxic effects of the cleaning spray.

Another method of cleaning the radiator is the use of steam or a steam cleaning device, if available. If the foreign deposits are hardened, it may be necessary to apply solvents.

The scale deposit inside the radiator is a result of using hard, high mineral content water in the cooling system. The effect of heat on the minerals in the water causes the formation of scale, or hard coating, on metal surfaces within the radiator, thereby reducing the transfer of heat. Some hard water, instead of forming scale, will produce a silt-like deposit which restricts the flow of water. This must be flushed out at least twice a year — more often if necessary.

To remove the hardened scale, a direct chemical action is necessary. A flushing compound such as sal-ammoniac, at the specified rate of 1/4 pound per each gallon of radiator capacity, should be added to the coolant water in the form of a dissolved solution while the engine is running. Operate the engine for at least fifteen minutes, then drain and flush the system with clean water.

Other flushing compounds are commercially available and should be procured from a reliable source. Most compounds attack metals and should not remain in the engine for more than a few minutes. A neutralizer should be used in the cooling system immediately after a de-scaling solvent is used.

For extremely hard, stubborn coatings, such as lime scale, it may be necessary to use a stronger solution. The corrosive action of a stronger solution will affect the thin metals of the radiator, thereby reducing its operating life. A complete flushing and rinsing is mandatory and must be accomplished skillfully.

After the solvent and neutralizer have been used and the cooling system is flushed, completely drain the entire system again and fill it with coolant (refer to Section 13.3). After filling the cooling system, inspect the radiator and engine for coolant leaks.

NOTICE: When draining or filling, the cooling system must be vented.

After the radiator core has been thoroughly cleaned and dried, reinstall the fan shroud and grill, if removed.

5.3 Radiator

DETROIT DIESEL 92

Remove Radiator

1. Remove the radiator filler cap and open the drain cock to drain the cooling system. Also open the drain cock on the oil cooler and the engine block.
2. Remove the bolts, lock washers and nuts which attach the fan guards to the fan shroud.
3. Loosen the hose clamps at the radiator inlet hose and remove the hose.
4. Loosen the hose clamps at the radiator outlet hose and remove the hose.
5. Use a chain hoist and a suitable lifting device (through the filler neck or otherwise) and draw the hoisting chain taut to steady the radiator.
6. Remove the bolts, lock washers, plain washers, nuts and bevel washers (if used) which attach the radiator shell to the engine base.

CAUTION: Since the shroud is very close to the tips of the fan blades, to prevent damage to these parts great care must be exercised whenever the radiator is removed.

7. Lift the radiator enough to clear the engine base and move it directly away from the engine.
8. Remove the fan shroud and the radiator core by removing the bolts securing them in place.

Inspection

Clean all radiator parts thoroughly, removing dirt, scale and other deposits.

Examine the radiator for cracks or other damage. The core fins should be straight and evenly spaced to permit a full flow of cooling air. The core tubes should be clean inside and outside and have no leaks.

If repainting the radiator core becomes necessary, it is recommended that a thin coat of dull black radiator paint or another high quality flat black paint be used. Ordinary oil paints have an undesirable glossy finish and do not transmit heat as well.

Check all radiator hoses and clamps. Replace cracked and deteriorated hoses and damaged clamps.

Install Radiator

Assemble the radiator, grill and shroud. Then mount the assembly on the engine base by reversing the procedure given for removal.

Check for clearance between the tips of the fan blades and radiator shroud after the radiator is in place. There must be sufficient clearance or damage to the fan and shroud will result when the engine is started. Use shims between the radiator and base, if necessary, to obtain the proper clearance.

CROSS-FLOW DESIGN RADIATOR

Certain vehicle engines incorporate a cooling system radiator of a cross-flow design rather than the conventional down-flow design.

As the name implies, a cross-flow radiator has a core of horizontally positioned tubes and coolant flow moves across rather than down the radiator.

Two reasons for using the cross-flow design radiator are:

1. The reduced height of the radiator permits a lower hood line design, thus providing better road visibility.
2. The area ahead of the engine crankshaft and below the radiator is open for mounting a power takeoff unit, if desired.

The intent here is to describe briefly how the cross-flow radiator functions and to identify some of the components unique in the cross-flow system.

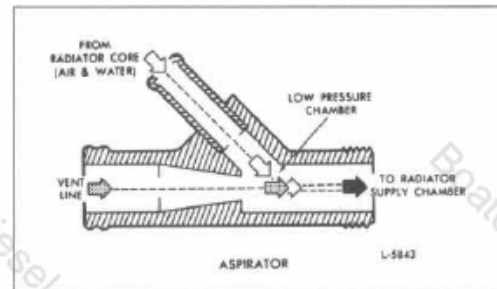

Fig. 1 - Aspirator for Cross-Flow Design Radiator

One such component is a Y-shaped device called an aspirator (Fig. 1) which is mounted externally on the filler cap side of the radiator and serves to rid the cooling system of air. The aspirator directs coolant under pressure through a venturi where entrapped air inside the radiator is picked up and moved to the supply chamber of the radiator where it is vented. The coolant line providing the drive flow originates

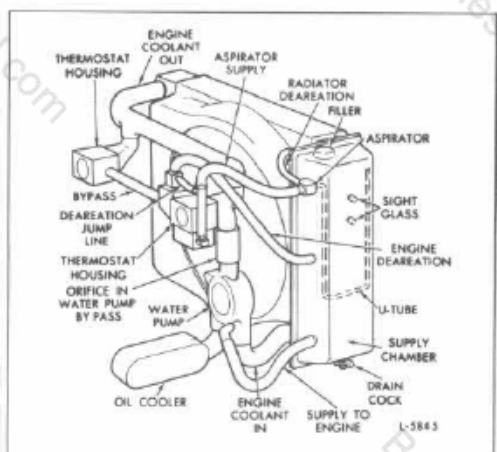

Fig. 2 - Cross-Flow Design Radiator

at the engine thermostat housing. This hookup provides a flow of coolant to the aspirator regardless of whether the thermostat is open or closed. As the coolant flow passes through the aspirator, its action pulls coolant and any air that is present from the top of the radiator core outlet chamber into an internal "U" tube which vents near the filler cap inside the radiator supply chamber to complete the deaeration process. This "U" tube insures that the entire cooling circuit, other than the supply chamber, remains completely full when the engine is stopped. Also, it keeps the coolant from seeking a common level throughout the system and, thereby, eliminates an aerated system at the next engine start-up.

The cross-flow system (Fig.2) requires a bypass restriction to provide sufficient pressure in the system for adequate engine deaeration and aspirator performance.

Properly installed hose connections are required for adequate cross-flow radiator efficiency (Fig. 2).

The cross-flow cooling system should always be drained at the radiator drain cock. This will insure that both

the radiator and internal "U" tube is empty. If the "U" tube is not emptied, refilling the system will prove difficult.

Due to the design of the cross-flow radiator, air may be trapped inside of the radiator during the fill process resulting in a false coolant level reading. Therefore, after filling the cooling system, the engine should be run approximately ten minutes at 1200-1400 rpm so that any entrapped air can be vented. Generally, additional coolant (approximately 3 to 4 quarts or 2.8 to 3.8 liters) will be required to bring the coolant to the proper level.

For efficient operation of the cross-flow radiator system, it is important that no leak exists between the radiator core and the supply tank. If an internal leak has developed between the radiator core and the supply tank, it can cause the cooling system to become aerated at low speed and following engine shut down. The radiator should be tested periodically for possible internal leaks. To determine if a leak is present, proceed as follows:

1. Remove the radiator cap and run the engine for approximately ten minutes at high idle to completely deaerate the cooling system. While the engine is running, add additional coolant to the supply chamber to bring the coolant level to the bottom of the filler neck.
2. Stop the engine and drain 4 quarts (3.8 liters) of coolant from the radiator.
3. Start and run the engine at high idle for approximately ten minutes and observe the coolant level.
4. Stop the engine and again observe the coolant level. If the coolant rises substantially in the supply tank, an internal leak is present and immediate corrective action should be taken to repair the leak. If the coolant level remains constant or falls, the system is satisfactory.
5. After the test is completed, refill the cooling system to the proper coolant level.

If the leak situation is not corrected, the engine will be operating with an aerated coolant for abnormal periods of time which could lead to an engine failure.

COOLANT PRESSURE CONTROL CAP

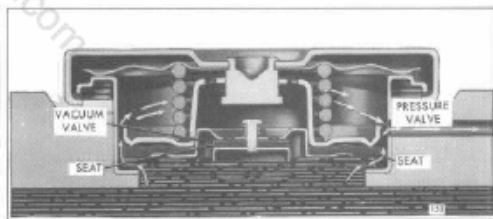

Fig. 1 - Pressure Control Cap (Pressure Valve Open)

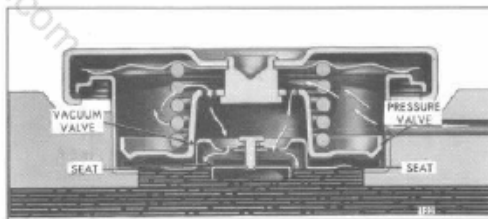

Fig. 2 - Pressure Control Cap (Vacuum Valve Open)

The radiator (or expansion tank) has a pressure control cap with a normally closed valve. The cap, with a number 7 stamped on its top, is designed to permit a pressure of approximately seven pounds (48 kPa) in the system before the valve opens while the cap with a number 9 stamped on its top needs nine pounds (62 kPa) before the valve opens. This pressure raises the boiling point of the cooling liquid and permits somewhat higher engine operating temperatures without loss of any coolant from boiling. To prevent the collapse of hoses and other parts which are not internally supported, a second valve in the cap opens under vacuum when the system cools.

CAUTION: Use extreme care when removing the coolant pressure control cap. Remove the cap *slowly* after the engine has cooled. The sudden release of pressure from a heated cooling

system can result in loss of coolant and possible personal injury (scalding) from the hot liquid.

To ensure against possible damage to the cooling system from either excessive pressure or vacuum, check both valves periodically for proper opening and closing pressures. If the pressure valve does not open between 6.25 psi (43.1 kPa) and 7.5 psi (51.7 kPa) or the vacuum valve does not open at .625 psi (4.3 kPa) (differential pressure) replace the pressure control cap.

It is recommended that all series 92 on-highway vehicle engines use a minimum 9 psi (62 kPa) pressure control cap. If the pressure valve does not open between 8 psi (55 kPa) and 10 psi (69 kPa) or the vacuum valve does not open at .625 psi (4.3 kPa) (differential pressure), replace the pressure control cap.

ENGINE COOLING FAN

The engine cooling fan (Fig. 1) is belt driven from the crankshaft pulley.

The three groove pulley hub (Fig. 2), used on 6V, 8V and certain 16V engines, turns on a double-row ball bearing at the front and a single-row (shielded) ball bearing at the rear of the hub. A new three groove pulley hub, for all engines including the 12V engines, turns on a front ball bearing and a rear roller bearing and also includes a hub cap (with relief valve), a dust cup and a grease fitting (Fig. 3). On 6V and 8V compact front end engines, the pulley hub turns on tapered roller bearings (Fig. 4). The Poly-V groove pulley hub used on some 16V engines turns on two single-row tapered roller bearings (Fig. 5).

Spacers provide a means for setting the proper clearance between the fan blades and the front groove of the crankshaft pulley.

Lubrication

The bearings and the cavity between the bearings are packed with grease at the time the fan hub is assembled. Refer to Section 15.1 for the maintenance schedule.

Fan Belt Adjustment

Adjust the fan belts periodically as outlined in Section 15.1.

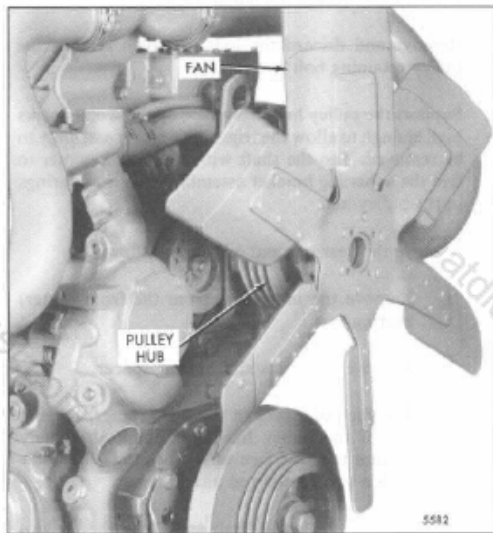

Fig. 1 - Typical Fan Mounting

Remove Fan, Hub And Adjusting Bracket

The fan blades must rotate in a vertical plane parallel with and a sufficient distance from the radiator core. Bent fan blades reduce the efficiency of the cooling system, may throw the fan out of balance, and are apt to damage the radiator core. Before removing the fan, check the blades for alignment. Do not rotate the fan by pulling on the fan blades.

1. Remove the attaching bolts, lock washers and nuts, then remove the fan and spacer (if used).

NOTICE: If insufficient clearance exists between the fan and the radiator, remove the fan, hub and adjusting bracket as an assembly.

2. Loosen the fan hub adjusting bracket bolts and remove the drive belts. Then withdraw the bolts and washers and remove the hub and bracket assembly from the engine.

Disassemble Fan, Three Groove Pulley Hub And Bracket (Fig. 2 And 3)

1. Remove the fan to hub mounting bolts, nuts and lock washers and detach the fan and spacer.
2. Remove and discard the hub cap. Then take out the cotter pin and remove the nut. If the bearings are to be removed, take out the retaining ring.
3. Support the hub, front face up, on wood blocks high enough to allow the bracket to be removed. Tap the fan shaft with a plastic hammer to free the fan shaft and bracket assembly from the bearings in the hub.
4. Remove the ball bearings from the pulley hub as follows:
 - a. Support the pulley hub, rear face up, on two wood blocks spaced far enough apart to permit removal of the bearing from the hub.
 - b. Tap the front bearing out of the hub by tapping alternately around the rear face of the bearing outer race with a small brass rod and hammer.
 - c. Reverse the pulley hub on the wood blocks and remove the rear bearing from the hub in the same manner.

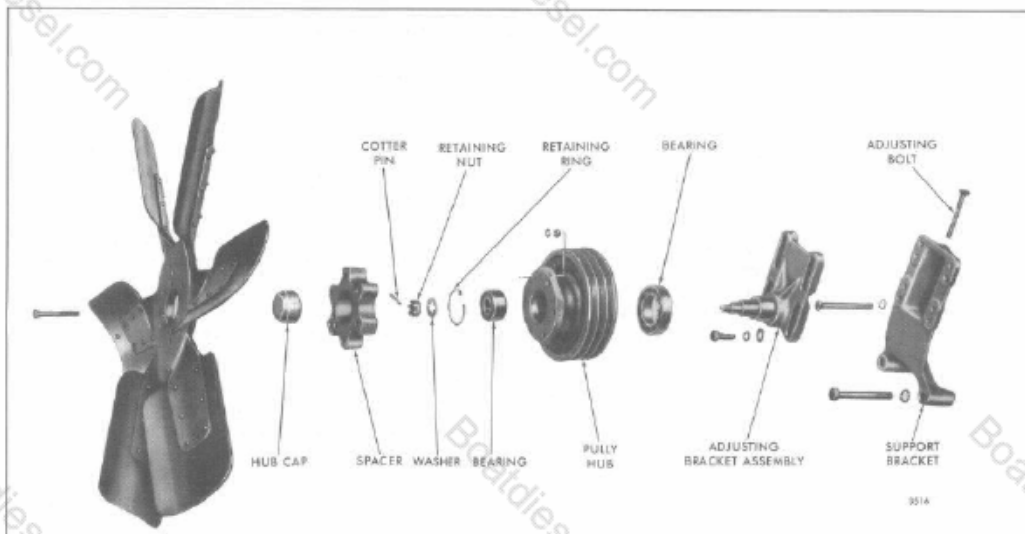

Fig. 2 - Typical Fan, Three Groove Pulley Hub and Adjusting Bracket Details and Relative Location of Parts (Former)

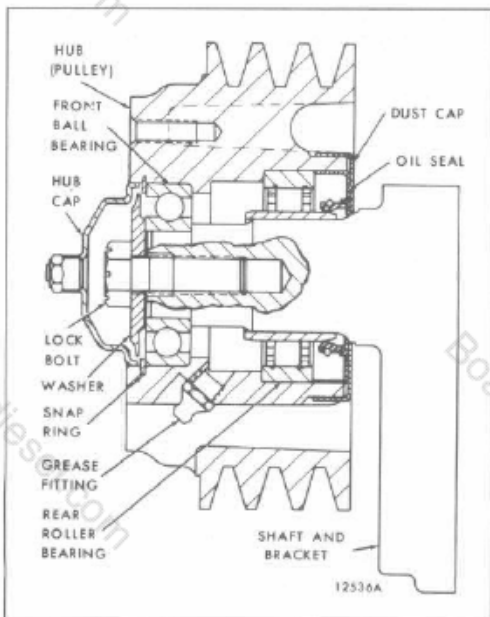

Fig. 3 - Three Groove Pulley Hub (Current)

Disassemble Fan, Hub And Bracket (Compact Front End - Fig. 4)

1. Remove the fan to hub mounting bolts, nuts and lock washers and detach the fan and spacer.
2. Remove and discard the hub cap, then remove the pulley retaining bolt and retainer.
3. Support the pulley hub, front face up, on wood blocks high enough to allow the adjusting bracket assembly to be removed. Tap the shaft with a plastic hammer to free the adjusting bracket assembly from the bearings in the pulley hub.
4. Remove the bearings and oil seal as follows:
 - a. Remove the inner race from the front (outer) bearing.
 - b. Remove the shims and bearing spacer.
 - c. Tap the outer race of the front (outer) bearing out of the pulley hub by tapping alternately around the rear face of the bearing outer race with a small brass rod and hammer.
 - d. Reverse the pulley hub and drive the oil seal from the hub. Discard the oil seal.

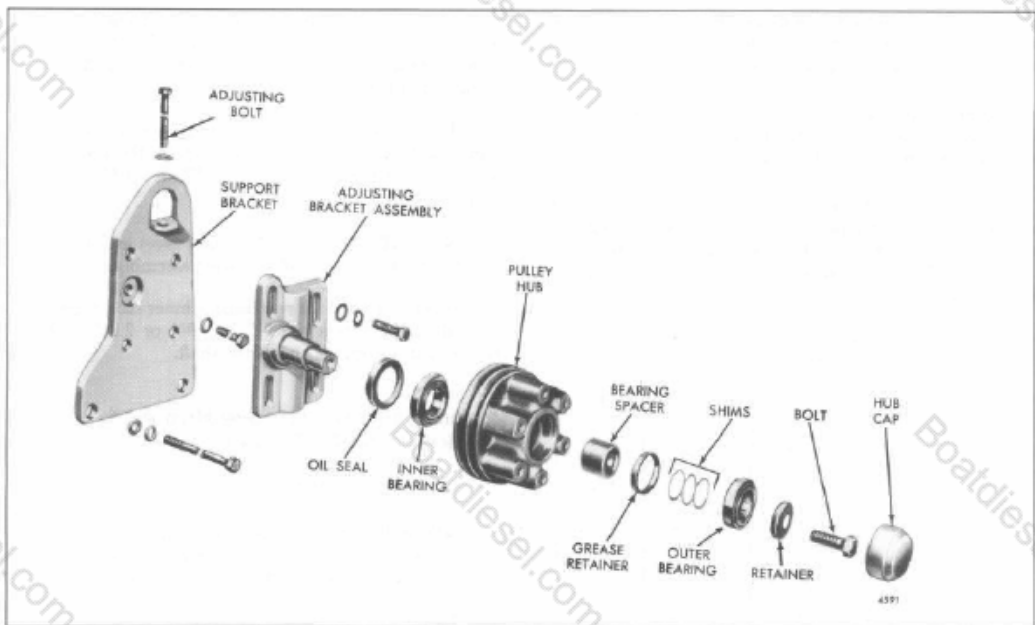

Fig. 4 - Fan Pulley, Hub and Adjusting Bracket Details for Compact Front End Engines

- e. Remove the rear (inner) bearing in the same manner as outlined in Steps a and c.
- f. Remove the grease retainer from the pulley hub.
6. Remove the inner roller bearing out of the hub by tapping alternately around the rear face of the bearing outer race with a small brass rod and hammer.
7. Remove the spacer and shims.
8. Reverse the pulley hub on the wood blocks and remove the front roller bearing from the hub in the same manner.

Disassemble Fan, Poly-V Groove Pulley Hub And Bracket (16V Engine)

1. Remove the fan to pulley hub mounting bolts, nuts and lock washers and detach the fan and spacer.
2. Remove and discard the hub cap. Then pry out that part of the locknut staked into the shaft and remove the nut.
3. Support the pulley hub, front face up, on wood blocks high enough to allow the adjusting bracket to be removed. Tap the shaft with a plastic hammer to free the bracket assembly from the bearings in the pulley hub.
4. Support the pulley hub, front face up, on two wood blocks spaced far enough apart to permit removal of the seal and bearing from the hub.
5. Remove and discard the felt oil seal in the rear of the hub.

Inspection

Clean the fan and related parts with clean fuel oil and dry them with compressed air.

CAUTION: To prevent possible personal injury, wear adequate eye protection and do not exceed 40 psi (276 kPa) air pressure.

Shielded bearings must not be washed; dirt may be washed in and the cleaning fluid could not be entirely removed from the bearing.

Examine the bearings for any indications of corrosion or pitting. Hold the inner race or cone so it does not turn and revolve the outer race or cup slowly by hand. If rough spots are found, replace the bearings.

Check the fan blades for cracks. Replace the fan if the blades are badly bent, since straightening may weaken the blades, particularly in the hub area.

Remove any rust or rough spots in the grooves of the fan pulley and crankshaft pulley. If the grooves are damaged or severely worn, replace the pulleys.

Examine and measure the fan hub shaft front and rear journals (industrial engines). The front journal diameter of a new shaft is .7866"-.7871" and the rear journal is 1.7705"-1.7713". If the journals are worn excessively, replace the fan shaft.

Look for cracks in the adjusting and support bracket castings. When replacement of either the fan shaft or adjusting bracket is necessary, a new fan shaft and bracket assembly must be used.

The current fan shaft rear bearing inner race should be inspected for any measurable wear. Replace the inner race if the outer diameter is less than 1.7297" or 2.6333" (Heavy Duty).

NOTICE: The inner and outer races are only serviced as a rear roller bearing assembly.

When installing the rear bearing inner race, press it on the shaft and position it 1.92" to 1.94" or 2.31" to 2.33" (Heavy Duty) from the end of the shaft.

Assemble Three Groove Hub And Bracket (Fig. 2)-Former

1. Install the rear bearing in the pulley hub.

NOTICE: When rebuilding a three groove pulley fan hub assembly for any reason, add the new hardened washer under the retaining nut.

2. To prevent the possibility of the inner bearing race spinning on the shaft, apply a small quantity of Loctite No. RC 601, or equivalent, to the full circumference of the rear bearing surface of the shaft. The bearing and shaft surfaces must be clean and dry.

NOTICE: Make sure no Loctite gets into the bearing.

3. Pack the cavity in the pulley hub 75% (minimum) full of grease. Use Texaco Premium RB or an equivalent Lithium base multi-purpose grease.
4. Place the adjusting bracket on wood blocks setting on the bed of an arbor press. Then press the pulley hub on the fan shaft.
5. Install the front ball bearing in the pulley hub.
6. Install the retaining ring and nut. Tighten the nut to 60-90 lb-ft (81-122 N•m) torque and secure it with a cotter pin.

NOTICE: If the holes in the nut and shaft do not line up for the cotter pin, do not back off on the nut but rather advance to the next position. Low nut torque will permit the front bearing to turn on the shaft.

7. Pack the front cavity 75% (minimum) full of grease (refer to Step 3) and install a new hub cap.

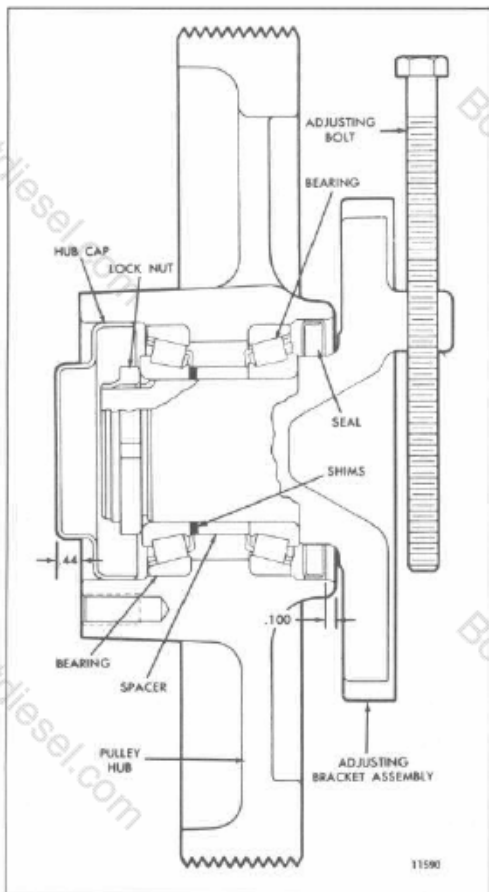

Fig. 5 - Typical 16V Engine Poly-V Groove Pulley Hub and Adjusting Bracket

Assemble Three Groove Hub And Bracket (Fig. 3)–Current

1. Apply Texaco Premium RB grease or an equivalent Lithium base multipurpose grease to the front ball bearing and the rollers of the rear bearing, before installing them in the pulley hub.
- NOTICE:** Do not overgrease.
2. Install the front ball bearing against the shoulder counterbore in the pulley hub. Then install the snap ring in the pulley hub.
3. Install the rear roller bearing outer ring and roller assembly against the shoulder in the counterbore of the pulley hub.
4. Install a new oil seal with rubber side flush with the outer edge of the hub.
5. Install the dust cap (if used) over the oil seal in the hub.
6. Place the shaft and bracket on wood blocks setting on the bed of an arbor press. Then press the rear bearing inner ring or race onto the fan shaft.
7. Pack the cavity in the hub 75% (minimum) full with Texaco Premium RB grease.
8. Install the partially assembled fan hub over the rear bearing inner ring on the shaft and against the shoulder on the pulley hub shaft.
9. Secure the hub with the washer and 1/2"–20 lock bolt. Tighten the bolt to 83–93 lb–ft (113–126 N•m) torque while rotating the pulley hub.
10. Fill a new fan hub cap 75% (minimum) full of grease and install it in the end of the pulley hub.

Assemble Hub And Bracket (Compact Front End – Fig. 4)

1. Apply Texaco Premium RB or an equivalent Lithium base multi-purpose grease to the rollers of both bearings before installing them in the pulley hub.
2. Install the rear (inner) bearing assembly (inner and outer race), with the protruding face of the inner race facing outward from the hub, by tapping alternately around the face of the bearing outer race with a small brass rod and hammer.
3. Install a new oil seal with the rubber side flush with the outer edge of the hub.
4. Place the adjusting bracket assembly on wood blocks setting on the bed of an arbor press. Then press the pulley hub on the fan shaft and install the bearing spacer.

5. Pack the cavity between the bearings 20–30% full of grease (refer to Step 1) and install the grease retainer.

NOTICE: The grease retainer is not required when a grease fitting is installed in the pulley hub (refer to Section 5.0).

6. Place the shims against the bearing spacer. Then install the front (outer) bearing assembly (inner and outer race), with the protruding face of the inner race facing outward from the hub, as mentioned in Step 2.
7. Secure the hub with the retainer and bolt. Tighten the 1/2"–20 bolt to 83–93 lb–ft (113–126 N•m) torque while rotating the pulley.
8. Rotate the assembly and check the end play with the spindle (shaft) in a horizontal position. The end play must be within .001" to .006". If necessary, remove the bolt, washer and front (outer) bearing and adjust the number and thickness of shims to obtain the required end play. Shims are available in .015", .020" and .025" thickness. Then reassemble the fan hub and check the end play.
9. Fill a new fan hub cap 75% (minimum) full of grease and install it in the end of the fan hub (pulley).

Assemble Poly-V Groove Pulley Hub And Bracket (16V Engine)

1. Before assembling the roller bearings into the pulley hub, pressure lubricate the bearings and pack the cavity in the hub 25% full of grease. Use Texaco Premium RB or an equivalent Lithium base multi-purpose grease.
2. Install the rear roller bearing in the pulley hub.
3. Press a new oil seal in .100" from the end of the pulley hub (Fig. 5).
4. Place the adjusting bracket on wood blocks setting on the bed of an arbor press. Then press the pulley hub on the fan shaft.
5. Install the spacer and necessary shims on the fan shaft.
6. Install the front roller bearing in the pulley hub.
7. Apply International Compound No. 2 to the threads of the locknut and tighten it with socket J 22556–2 and fingers J 6534–8 to 250–260 lb–ft (339–352 N•m) torque while rotating the pulley hub.

NOTICE: Reverse the fingers J 6534–8 in socket J 22556–2 (chamfered holes in fingers facing the socket) when fingers are used to tighten the 16V Poly-V groove pulley hub locknut.

8. Check the end play. It must be .001" to .006". If necessary, remove the locknut and front bearing and add or remove shims as required.
9. After the specified end play is obtained, remove the locknut and front bearing and fill the pulley hub cavity 20-30% full of grease (refer to Step 1). Then reinstall the front bearing and locknut.
10. Tighten the locknut to 250-260 lb-ft (339-352 N•m) torque and stake the locknut to the fan shaft.
11. Fill a new hub cap 75% (minimum) full of grease and install it in the pulley hub (Fig. 5).

Install Fan, Hub And Bracket

1. Secure the fan and spacer to the pulley hub with the six bolts, nuts and lock washers. Tighten the nuts to 15-19 lb-ft (20-26 N•m) torque.

2. Place the fan belts on the pulley.

NOTICE: Before a Poly-V belt is installed (16V engines), it is very important that the crankshaft pulley and fan pulley are in alignment (refer to Section 15.1).

3. Position the fan, hub and adjusting bracket against the support bracket and install the bolts finger tight in the support.

NOTICE: The new bolts differ from the former in that their effective lengths in inches are indicated in 1/4" high raised numbers on the bolt heads. This makes them easier to identify than the former bolts which had to be measured. Some of the new bolts are also longer than the bolts they replace.

4. Adjust the bracket to provide the proper tension on the fan belts (refer to Section 15.1). Tighten the bracket and bracket adjusting bolts.

THERMO-MODULATED FAN

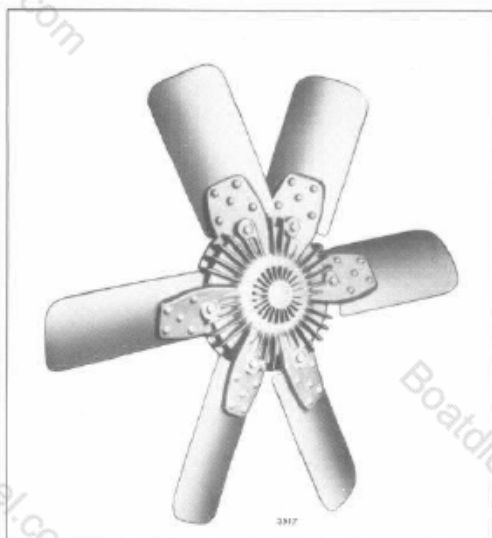

Fig. 6 - Typical Thermo-Modulated Fan Assembly

A thermo-modulated suction fan assembly has been provided on some engines (Fig. 6).

This fan assembly is designed to regulate the fan speed and maintain an efficient engine coolant temperature regardless of the variations in the engine load or outside air temperature.

The entire fan drive assembly is a compact integral unit (Fig. 7) which requires no external piping or controls and operates on a simple principle. This principle consists of transmitting torque from the input shaft to the fan by the shearing of a silicon fluid film between the input and output plates in a sealed multiplate, fluid filled clutch housing.

The thermostatic control element, which is an integral part of the fan drive, reacts to changes in engine temperature and varies the fluid film thickness between the plates and thereby changes the fan speed. Proper selection of the control element setting is determined by the vehicle manufacturer to maintain optimum cooling and no further adjustment should be necessary.

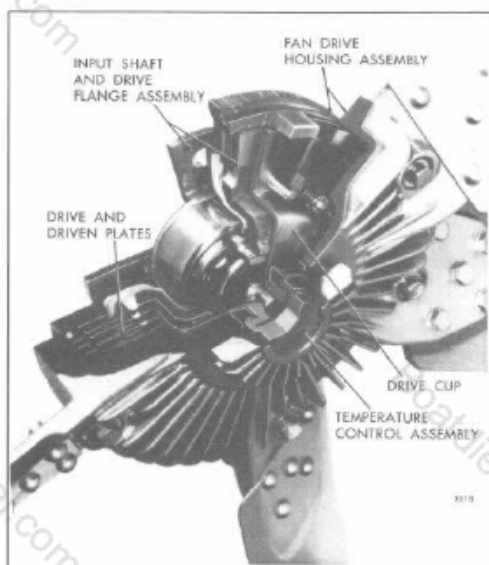

Fig. 7 - Typical Thermo-Modulated Fan Drive Assembly

The thermo-modulated fan is mounted and driven by the engine in the same manner as the conventional fan.

Lubrication

The fan drive assembly is prelubricated by the manufacturer. However, the drive fluid level and the roller bearing should be checked periodically (refer to Section 15.1).

Adjust Fan Belt

The adjustment of the fan belt tension is the same as on the conventional type fans.

Remove And Install Fan And Drive Assembly

The fan blades and fan drive may be taken off by removing the four shaft to pulley mounting bolts, and installed by reversing this procedure.

HEAT EXCHANGER

The heat exchanger core consists of a series of cells with a header at one end and a circular water outlet at the opposite end. The core is mounted inside of the expansion tank with the header or inlet end bolted to the tank and the opposite or outlet end is sealed inside a retainer. A gasket between the expansion tank and the flange of the core, another gasket between the flange of the core and the cover at the inlet side, and seals surrounding the circular outlet at the opposite end prevent the coolant from mixing with the raw cooling water on its horizontal course between the cells of the element.

In this system of engine cooling, the hot coolant leaving the thermostat housing passes through the expansion tank, then through the cells of the cooling core. After leaving the heat exchanger, the engine coolant is picked up by the fresh water pump and circulated through the cylinder block and cylinder heads. The raw water is forced horizontally between the cells of the core and serves to lower the temperature of the coolant as it passes through the cells.

To protect the heat exchanger core from electrolytic action of the raw water, a zinc electrode is located in both the heat exchanger inlet elbow and the raw water pump inlet elbow and extends into the raw water passage (Fig. 1).

The expansion tank provides a means of filling the engine cooling system, as well as space for expansion of the coolant as its temperature rises. An overflow pipe, near the top of the tank, provides a vent to the atmosphere.

NOTICE: When installing a new filler neck in the expansion tank, be sure to drill a 3/16" hole in the side of the new filler neck for the overflow pipe.

The length of time a heat exchanger will function satisfactorily before cleaning will be governed largely by the kind of coolant used in the engine, and the kind of raw water used.

Soft water, plus a good commercial rust inhibitor or antifreeze should be used as the engine coolant (refer to Section 13.3) to prevent lime deposits in the heat exchanger core as well as in the engine.

Enough coolant should be maintained in the engine to fill the cylinder block and head and to partially fill the water tank. Allow air space above the coolant in the tank for the increase in volume as the temperature of the coolant rises.

Whenever the heat exchanger fails to cool the engine properly, and the raw water pump is circulating a normal amount of cooling water around the heat exchanger core, the core should be examined for foreign deposits.

Clean Heat Exchanger Core

When foreign deposits accumulate in the heat exchanger to the extent that cooling efficiency is impaired, remove the heat exchanger core and clean it as follows:

Immerse the heat exchanger core in a scale solvent consisting of one-third (1/3) muriatic acid and two-thirds (2/3) water to which one-half (1/2) pound of oxalic acid has been added to each two and one-half (2-1/2) gallons of solution. Remove the core when foaming and bubbling stops. This usually takes from thirty to sixty seconds. Flush the core thoroughly with clean hot water under pressure.

To prevent drying and hardening of accumulated foreign substances, the heat exchanger core must be cleaned as soon as possible after removing it from service.

Inspect Zinc Electrodes

Remove the zinc electrodes from the inlet side of the raw water pump and the heat exchanger. Clean the electrodes with a wire brush or, if worn excessively, replace with new electrodes. To determine the condition of a used electrode, strike it sharply against a hard surface; a weakened electrode will break.

Remove Heat Exchanger Core (6 And 8V Engines)

Remove heat exchanger core for cleaning and inspection as follows:

1. Drain the engine coolant and the raw water system.

CAUTION: To avoid being burned by the hot liquid, allow the engine to cool before draining the coolant.

2. Remove the four bolts and lock washers that hold the raw water inlet tube to the heat exchanger. Then withdraw the inlet tube and gasket.
3. Remove the ten bolts and lock washers that hold the heat exchanger inlet cover to the expansion tank.
4. Remove the four bolts and lock washers that hold the outlet tube to the cover. Then remove the outlet tube and gasket.
5. Remove the ten bolts and lock washers that hold the outlet cover and seal retainer to the expansion tank.
6. Withdraw the outlet cover and seal retainer, together with the seals and seal gland, from the expansion tank. Remove the gasket.
7. Withdraw the heat exchanger core and gasket from the expansion tank.

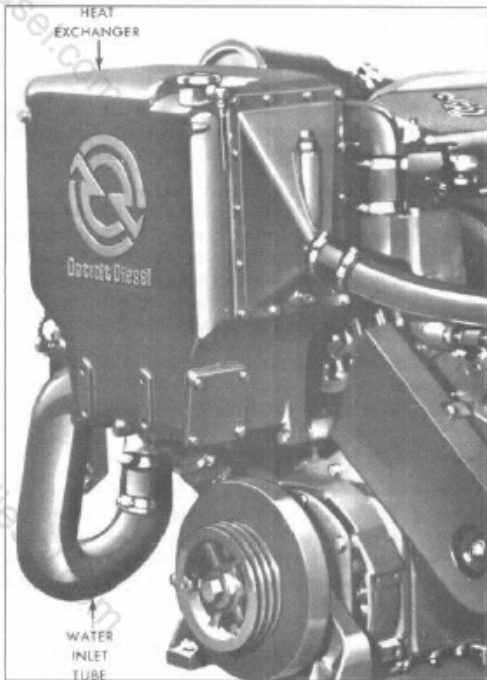

Fig. 1 - Typical Heat Exchanger Mounting

Remove Heat Exchanger Core (8VTI And 16V Engines)

1. Drain the fresh and raw water systems by opening the drain cocks in the cylinder block and the heat exchanger cover respectively.

CAUTION: To avoid being burned by the hot liquid, allow the engine to cool before draining the coolant.

2. Remove the bolts that hold the inlet cover and the heat exchanger core to the tank. Remove the cover and the gasket.
3. Remove the bolts that hold the outlet cover to the seal retainer. Remove the cover and gasket.
4. Remove the bolts that hold the seal retainer to the tank. Remove the seal retainer, together with the seals and the seal gland, away from the tank.
5. Withdraw the heat exchanger core and gasket from the tank.

Install Heat Exchanger Core

After the heat exchanger core has been cleaned and inspected, install it by reversing the sequence of operations given for removal, using new gaskets and seals.

NOTICE: To minimize electrolytic action of the raw water, brass pipe plugs are used in the raw water system components wherever pipe plugs are required.

Refill the fresh and raw water systems and check for leaks.

RAW WATER PUMP (Jabsco)

Raw water for lowering the temperature of the engine coolant is circulated through the heat exchanger by a positive displacement pump (Fig. 1). The pump is attached to an adaptor which in turn is bolted to the flywheel housing and is driven through a coupling attached to the left-hand camshaft gear.

The pump drive shaft is supported by a pre-lubricated, shielded double-row ball bearing. An oil seal prevents oil leakage from the bearing compartment and a rotary type seal prevents water leakage along the shaft.

An impeller, splined to the end of the drive shaft, is self-lubricated by the water pumped and should not be run dry for longer than normally required for the pump to prime itself.

A wear plate in the impeller compartment prevents wear of the pump housing and can be reversed if wear on the plate becomes excessive. A slot machined in the outer periphery of the wear plate registers with a dowel in the pump housing, thus preventing it from rotating with the shaft.

The pump can be operated in a clockwise or counterclockwise direction. Raw water is drawn into the pump through an inlet opening and discharged through the outlet opening, both openings being located at the top of the pump housing.

Replace Pump Seal

Seal parts may be removed and replaced with new parts by removing the impeller, but without removing the pump from the engine.

NOTICE: Use care not to scratch or burr the lapped surface of the seal seat or that portion of the shaft which the seal contacts.

1. Remove cover screws and lift cover and gasket from the housing (Fig. 2).
2. Using two pliers, grasp a blade at each side of impeller and pull impeller from shaft. The spline plug will come out with the impeller.
3. Insert two wires, each with a hook at one end, between the housing and the seal with the hooks over the edge of the carbon seal. Pull the seal assembly from the shaft.
4. The seal seat and gasket may be removed in the same manner.
5. If removed, place a gasket and seal seat over the shaft and press them into position in the seal cavity.

6. Assemble the carbon seal, seal ring and washer in the correct relative position, and slide them over the shaft and against the seal seat. Care must be used to assure that the seal ring is contained snugly within the ferrule, thereby gripping the shaft.
7. Install the Marcel washer next to the flat washer.
8. Compress the impeller blades to clear the offset cam and press the impeller onto the splined shaft. Install the spline plug.
9. Turn the impeller several turns in that direction in which it will normally operate, to position the blade properly.
10. Install the cover on the housing, using a new gasket.

Remove Raw Water Pump From Engine

If complete disassembly or replacement of the pump becomes necessary, refer to Fig. 1 and proceed as follows:

1. Drain the raw water system.
2. Loosen the hose clamps at the outlet elbow and intermediate tube and slide the hose along the tube.
3. Loosen the hose clamps at the inlet elbow and the inlet tube and slide the hose along the tube.

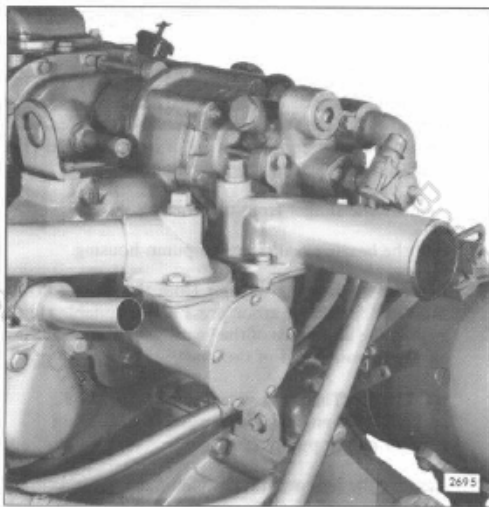

Fig. 1 - Raw Water Pump Mounting

5.6 Raw Water Pump

DETROIT DIESEL 92

4. Remove the bolts and lock washers holding the inlet and outlet elbows to the pump and lift the elbows from the pump. Remove the gaskets.
5. Remove the adaptor to flywheel housing bolts and lock washers.
6. Loosen the pump from the flywheel housing by tapping on the edge of the adaptor with a soft hammer.
7. Withdraw the pump straight out from the flywheel housing, disengaging the drive gear from the coupling.

NOTICE: Cover the pump opening in the flywheel housing with a clean cloth to prevent the entrance of foreign matter.

Disassemble Pump

Refer to Fig. 2 and disassemble the pump as follows:

1. Remove the seal assembly as previously outlined.
2. Mark the housing and the adaptor for reference when reassembling, then remove the bolts and lock washers and separate the adaptor from the housing.
3. Clamp the drive gear in a soft-jawed vise and remove the retaining nut and lock washer from the shaft.
4. Take the gear from the vise and, using a suitable puller, pull the gear from the shaft. Remove the Woodruff key from the shaft.
5. Remove the bearing retainer from the groove in the housing.
6. Support the pump housing in an arbor press with the mounting flange resting on the bed of the press and the splined end of the shaft under the ram of the press. Use a brass rod between the shaft and the ram and press the shaft and ball bearing from the housing.
7. Remove the slinger from the housing.
8. Pull the bearing seal from the pump housing.
9. Remove the bearing retainer from the groove in the shaft and, using an arbor press and a suitable sleeve against the inner race of the bearing, press the bearing off the threaded end of the shaft.

NOTICE: The raw water pumps on 8V-92 and 16V-92 engines do not have a bearing retainer on the pump shaft.

10. Remove the bolt and lift the cam from the housing.
11. Lift the wear plate off the dowel.

Inspect Pump Parts

After disassembly, clean all parts thoroughly, except the bearing. The *shielded bearing must not be washed*; dirt may be washed in and the cleaning fluid could not be entirely removed from the bearing. Wipe the bearing clean on the outside and then inspect it. Hold the inner race and revolve the outer race slowly to detect possible wear or rough spots. Replace the bearing if it is worn or does not roll freely.

Examine the parts of the seal assembly, the ball bearing seals and discard any parts that have been cut, cracked or otherwise damaged.

Inspect the oil seal contact surfaces of the shaft for scratches or grooves. Smooth scratched surface with crocus cloth wet with fuel oil.

Inspect the impeller to make sure the bond between the neoprene and the metal is good. If the impeller blades have a permanent set, install a new impeller.

Remove burrs from the wear plate. If wear on the plate is excessive, it may be reversed when the pump is assembled.

Assemble Pump

Using new parts where required, assemble the pump as follows:

1. Install the wear plate in the pump housing with the locating hole in the plate over the dowel in the housing.
2. Place the cam in the housing so the end of the cam is flush with the end of the housing and install the bolt.
3. Support the splined end of the shaft on a wood block on the bed of an arbor press. Start the bearing straight on the shaft and, using a sleeve between the ram of the press and the inner race of the bearing, press the bearing tight against the shoulder on the shaft.
4. Install the bearing retainer in the groove on the shaft.
5. Install the bearing seal(s) in the housing with the lip facing towards the bearing.
6. Place the slinger in position and then press the shaft and bearing into the counterbore in the housing.
7. Install the bearing retainer in the groove in the housing.
8. Install a Woodruff key in the shaft and start the gear straight on the shaft over the key.

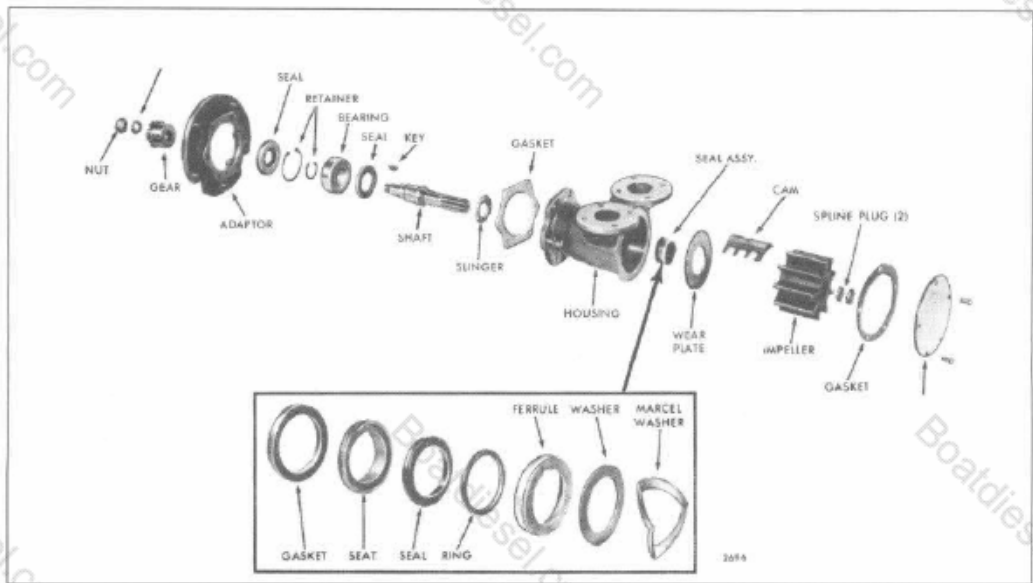

Fig. 2 - Raw Water Pump Details and Relative Location of Parts

9. Place the housing in an arbor press, with the splined end of the shaft supported on a wood block, and press the gear tight against the shoulder on the shaft.
10. Clamp the gear in a soft-jawed vise and install the lock washer and retainer nut. Tighten the nut to 25-30 lb-ft (34-41 Nm) torque. Do not exceed the specified torque, otherwise shaft fracture and consequent early pump failure may result.
11. Position the adaptor on the housing by aligning the marks made when disassembling and install the six lock washers and bolts.

Install Raw Water Pump On Engine

The pump may be installed by reversing the procedure used for removal.

Note that the end cover is marked to show the outlet port for RH rotation and the outlet port for LH rotation.

Follow these markings when installing the raw water pump to avoid any difficulty regarding direction of flow. Also, when installing the inlet elbow or the outlet elbow, be sure to use two flat washers on the bolt being installed in the blind hole in pump housing.

COOLANT FILTER AND CONDITIONER

The engine cooling system filter and conditioner is a compact by-pass type unit with a replaceable canister type element (Fig. 1), a spin-on type element (Fig. 2) or a clamp-on type element (Fig. 3).

A correctly installed and properly maintained coolant filter and conditioner provides a cleaner engine cooling system, greater heat dissipation, increased engine efficiency through improved heat conductivity and contributes to longer life of engine parts.

The filter provides mechanical filtration by means of a closely packed element through which the coolant passes. Any impurities such as sand and rust particles suspended in the cooling system will be removed by the straining action of the element. The removal of these impurities will contribute to longer water pump life and proper operation of the thermostat.

The filter also serves to condition the coolant by softening the water to minimize scale deposits, maintain an acid-free condition and act as a rust preventive.

Corrosion inhibitors are placed in the element and dissolve into the coolant, forming a protective rustproof film on all of the metal surfaces of the cooling system (refer to Section 13.3). The other components of the element perform the function of cleaning and preparing the cooling passages while the corrosion inhibitors protect them.

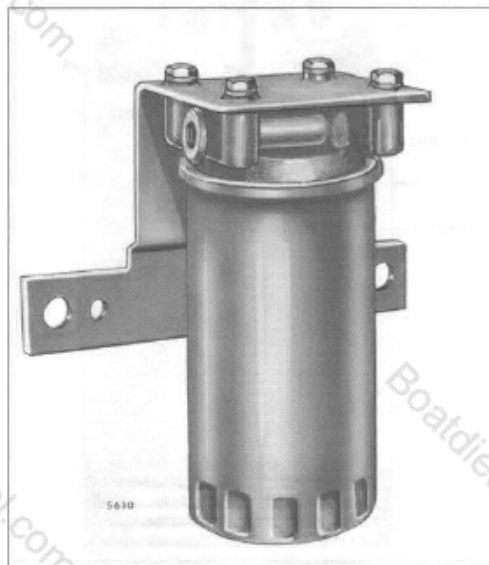

Fig. 2 – Coolant Filter and Conditioner (Spin-On Type)

Filter Installation

If a coolant filter and conditioner is to be installed on an engine which has been in service, drain and flush the cooling system prior to installation of the filter.

Filter Maintenance

Replace the chemically activated element, following the manufacturer's recommended change periods (refer to Section 15.1). The lower corrosion resistor plate (if used) must be buffed each time (discard the plate if excessive metal loss or pitting is evident) to ensure effective protection of the cooling system.

If the filter is installed on an engine which has previously been in service, it may be necessary to change the filter element two or three times at intervals of approximately 200 hours or 6,000 miles, or less, to clean up accumulations of scale and rust in the cooling system. It is advisable to drain and flush the system during these initial change intervals.

Make-up water up to 40% of the total capacity of the cooling system may safely be added before a filter element change is required.

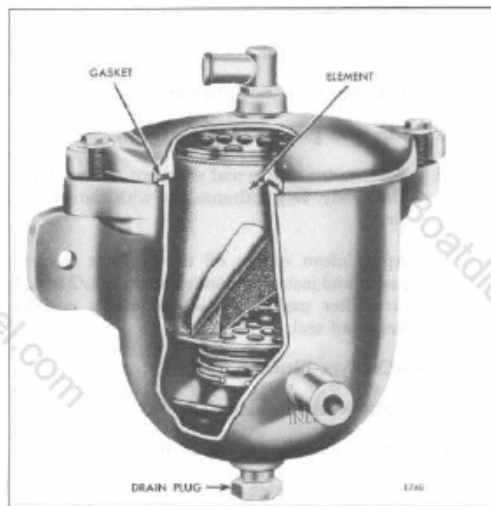

Fig. 1 – Coolant Filter and Conditioner (Canister Type)

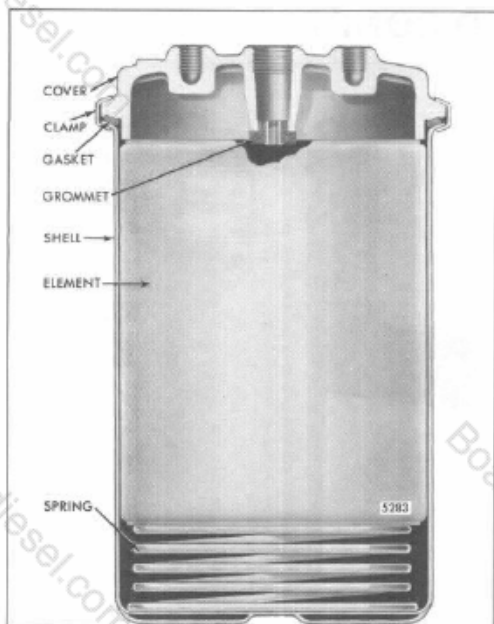

Fig. 3 – Coolant Filter and Conditioner (Clamp-On Type)

NOTICE: Sea water must never be used for make-up water in a marine engine, except under emergency conditions. If it is necessary to use sea water, the cooling system must be completely drained and flushed with fresh water upon reaching port. The filter element must be changed. Filters with resistor plates must be inspected for pitting. *Presence of salt in the coolant results in rapid pitting of the resistor plates.*

If it is necessary for any reason to drain the cooling system before an element change, the treated water should be saved and re-used. If the treated water is discarded, a new filter element must be installed since the protective agents in the used filter will have been partially consumed in treating the discarded water.

Service

The coolant filter may be grounded at the option of the user.

The current coolant filter includes a non-chromate type element. This element can be used in place of either of the former filter elements (permanent type antifreeze or

plain water type) and thus provides year around cooling system protection. The current and the former filter elements are completely interchangeable in the former filter can (refer to Section 13.3).

Replace the element and service the filter and conditioner as follows:

1. Close the filter inlet and outlet shut-off valves. If shut-off valves are not provided, vise grip pliers can be used to clamp each hose closed during the filter change. Use caution to avoid damaging the hoses with the vise grip pliers.
2. Canister Type Element:
 - a. Remove the drain plug in the bottom of the filter body and let drain.
 - b. Remove the filter cover-to-filter body bolts.
 - c. Remove and discard the element.
 - d. Remove and discard the corrosion resistor plates.
 - e. Remove the sludge and sediment and wash the filter body. Dry it thoroughly with compressed air.
 - f. Replace the drain plug in the bottom of the filter.
 - g. Insert the new element.
 - h. Use a new filter cover gasket and install the filter cover and tighten the bolts evenly.
3. Spin-On Type Element:
 - a. Remove and discard the element.
 - b. Clean the gasket seal on the filter cover.
 - c. Remove the sludge and sediment and wash the filter body. Dry it thoroughly with compressed air.
 - d. Apply clean engine oil to the filter element gasket and install the new element. A 1/2 to 3/4 turn after gasket contact assures a positive leakproof seal.
4. Clamp-On Type Element:
 - a. Remove the retaining clamp.
 - b. Remove and discard the element.
 - c. Remove the sludge and sediment and wash the filter body. Dry it thoroughly with compressed air.

- d. Insert the new element.
- e. Secure the filter body in place with the clamp.
5. Open the inlet and outlet lines by opening the shut-off valves or removing the vise grip plier clamps.
6. Operate the engine and check for leaks. The top of the filter and the outlet line should feel warm to the touch with the rise in coolant temperature. If not, disconnect the filter outlet line at the end opposite the filter connection to bleed the air from the system and reconnect the line. Use caution to minimize coolant loss.

SHOP NOTES - SPECIFICATIONS - SERVICE TOOLS

SHOP NOTES

FAN HUB GREASE FITTING

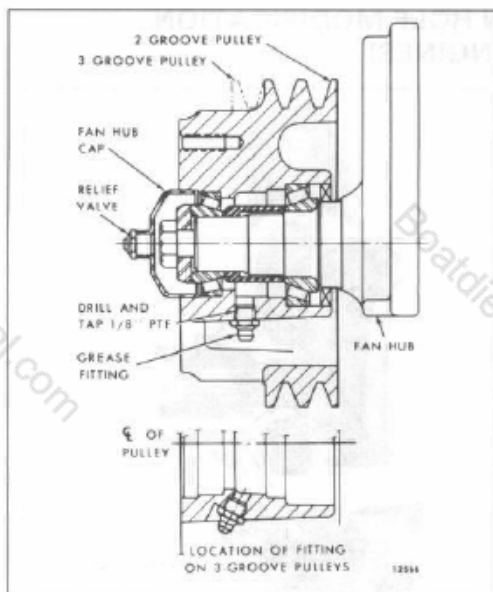

Fig. 1 - Location of Fan Hub Grease Fitting and Relief Valve

A grease fitting may be added to former fan hub assemblies used on vehicle engines to permit periodic lubrication of the bearings.

Rework the fan hub, as follows:

1. Refer to Section 5.4 and disassemble the fan hub assembly and clean the parts thoroughly.
2. Drill and tap the fan hub, at the location shown in Fig. 1, to accept a 1/8"PTF x 11/16" threaded lubricator fitting. Clean the hub to remove any metal chips.
3. Refer to Section 5.4 and reassemble the fan hub. Discard the former grease retainer as it is not required when a grease fitting is used.
4. Install a new fan hub cap which is threaded for a relief valve (Fig. 1).
5. Install a grease fitting in the fan hub and a relief valve in the fan hub cap.

Refer to Section 15.1 for the maintenance schedule.

DRAINING JABSCO RAW WATER PUMP

Although all engine units are provided with draincocks for the purpose of draining the cooling system, a small amount of coolant may remain in the impeller housing of a "Jabsco" pump.

Under normal circumstances, there would be no need in completely draining the impeller housing of a raw water pump, therefore, no drain plug has been incorporated at this location. However, certain models employ a raw water pump in conjunction with a fresh water cooling system.

In the event the engine is to be stored in below freezing temperatures, it is suggested that, in addition to draining the cooling system of the engine unit, the impeller housing of the "Jabsco" pump (if so equipped) be completely drained. This may easily be accomplished by loosening the five (5) fillister head screws which attach the end cover to the pump housing, at the impeller end of the pump; then, pulling the end cover away from the pump body, while being careful to avoid damage to the gasket. The screws need only be loosened sufficiently to allow complete draining of the impeller housing then, the screws retightened.

RAW WATER PUMP IMPELLERS

The Jabsco raw water pump is equipped with synthetic rubber impellers. Since the synthetic rubber begins to lose its elasticity at low temperatures, impellers made of natural rubber may be installed when it is necessary to pump raw water that has a temperature below 40°F (4°C). However, the

standard impellers must be used when the pump operates in warmer water.

New service impellers of natural rubber are identified by a stripe of green paint.

FRESH WATER PUMP DRAIN HOLE MODIFICATION (6V AND 8V ENGINES)

After disassembling and thoroughly cleaning the water pump housing, modify the drain hole as follows:

1. After all rust and deposits have been removed from inside the pump body, paint the cavity with Rust-Oleum (Rust-Oleum No. 769 © Damp Proof Red Primer or equivalent).

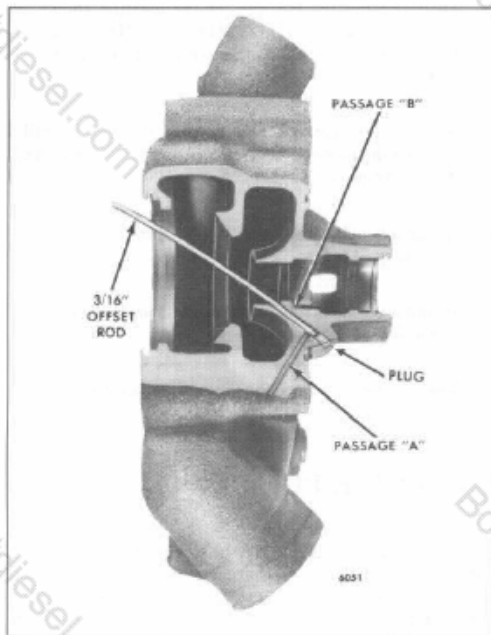

Fig. 2 - Water Pump Housing before Modification

NOTICE: The inside of the pump body may require cleaning with a wire brush to ensure paint adhesion. Be careful not to damage the oil and water seal areas. Reference instructions on the paint containers. Excess paint should be removed from the oil seal area.

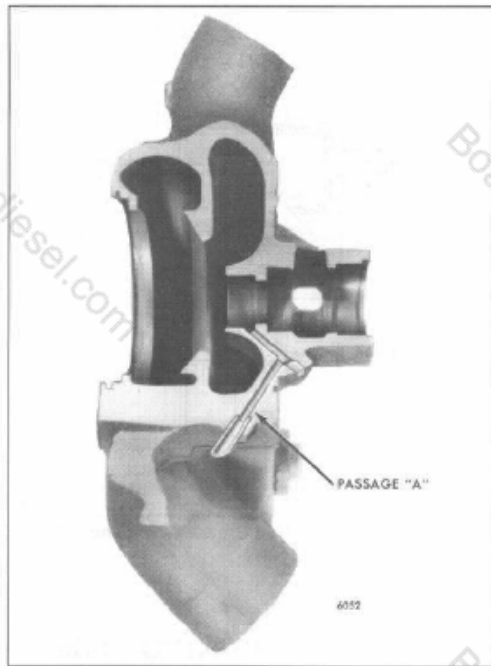

Fig. 3 - Water Pump Housing after Modification

2. With a 3/16" (.1875") offset rod, drive the plug out of passage B (Fig. 2).
3. Clean and clear passage B of debris, using a 7/32" (.2188") drill.
4. Enlarge passage A using a 7/32" (.2188") drill approximately 2 1/2", or until the drill bit meets resistance from the wall of passage B.
5. Drill the bottom of passage A approximately 1/2" using a 19/64" (.2969") drill. Be sure the drill follows the existing drain hole.

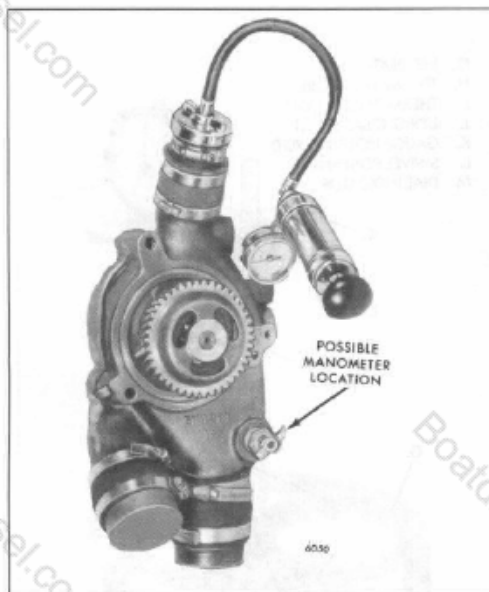

Fig. 4 - Testing Modified Water Pump Housing

6. Clean the pump body of all metal chips.
7. Press a 5/16" O.D. x 1 1/4" long steel tube into passage A until it bottoms out (Fig. 3). Cut the tube at a 45° angle with the flat or short side of the tube positioned to the engine side, away from the air flow.
8. Apply a small quantity of Loctite Sealant 601 or equivalent and install a new plug into passage B.

NOTICE: After the pump body has been completely reworked, inspect the area indicated by Arrow 1 (Fig. 3) for breakthrough. If the drill broke through, the body **should not** be used.

9. Assemble the water pump as outlined in Section 5.1.
10. After the water pump is assembled, it is suggested that an air leak test be performed with a pressure testing kit such as that shown in Fig. 4. Attach the manometer at the water pump drain cock hole, then use the hand pump to raise the mercury manometer to 20 in. or 9.9 psi (68 kPa). If the manometer does not decrease in excess of .2 in. or .1 psi (68 kPa) in 60 seconds, the pump has met the air leak test criteria. If the pump does not meet this criteria, turn the pump shaft to be sure the seal is not being held off the ceramic and perform the air leak test a second time.

THERMOSTAT FUNCTION TESTING

Thermostat print specifications normally call for three specific operating conditions: namely, start-to-open temperature, full-open temperature, and full-open dimension. The most important of these is the *start-to-open* temperature. This is the temperature at which the motor mechanism (wax compound) experiences a change from a solid to a liquid, expanding and opening the thermostat to allow coolant flow. At full-open temperature, the liquid wax is fully expanded and the full-open dimension is reached, ensuring proper coolant flow to the radiator. The start-to-open temperature is normally stamped or printed on the thermostat.

A definite relationship exists between the start-to-open temperature and operating stroke (full-open travel) of the thermostat. This relationship may be seen in the illustration below. The normal tolerance for the start-to-open temperature is +2°F or -3°F (+1.11°C or -1.67°C).

To ensure that sufficient coolant flows through the radiator to control engine temperature, the start-to-open temperature and the full-open dimension of the thermostat should be checked. Thermostats may be tested on the simple fixture shown (Fig. 7). This fixture can be made from readily available materials.

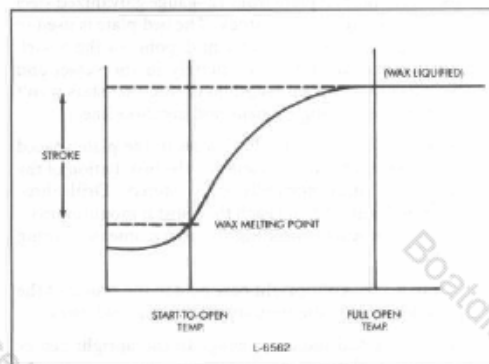

Materials

1. Stainless steel or non-ferrous metal vessel approximately 8" diameter by 6" deep
1. 2000 watt immersion-type heating element
1. Thermostatic control having a 60°F to 230°F (15.6° to 110°C) temperature range and a capillary tube sensing device

5.0 Shop Notes

DETROIT DIESEL 92

- 1 12" length of 1/4" copper tubing
- 1 3/8" drain valve
- 1 7-1/2" diameter piece of 12-gauge galvanized sheet steel or 1/8" aluminum (for bed plate)
- 1 Bulkhead fitting
- 1 Air control valve
- 1 Laboratory thermometer with a 60°F to 230°F (15.6°C to 110°C) range
- 1 Dial indicator having a one inch travel with a 3/8" gauge holding rod and swivel post lock screw

The thermostat test fixture consists of the test vessel with control (Fig. 6) and the test plate assembly (Fig. 5).

Making the Test Fixture

1. Drill a 1/8" hole in the side of the vessel and braze a bulkhead fitting to the vessel to accept an air control valve. Shop air will be used to agitate the water and relieve temperature stratification within the vessel.
2. Manufacture an aeration line from a 12" length of 1/4" copper tubing by drilling four equally spaced 1/8" holes in the tube and crimping or blocking one end. Attach the open end of the tube to the air valve and bend the tube to the inside contour of the vessel.
3. Install a 3/8" drain valve in the lower portion of the vessel.
4. Fabricate the bed plate from 12-gauge galvanized steel or 1/8" aluminum sheet stock. The bed plate is used to suspend the thermostat at a mid-point in the vessel. This component must fit squarely in the vessel and have legs of sufficient length to ensure that stats won't contact the heating element and aeration line.

Bore 1 9/16", 2", and 2 3/4" holes in the plate spaced 120° from each other to facilitate the installation of the variety of stats normally encountered. Drill three 7/16" holes at 60° from each thermostat mounting bore for conveniently locating a thermometer during testing.

Install a 3/8" x 8" upright base post in the center of the plate to provide the mounting for a dial indicator.

5. Attach the dial indicator gauge to the upright center post of the plate to permit accurate thermostat travel measurement. The bed plate and dial indicator shown have components added to raise the indicator vertically above the gauge holding rod; however, the extra items are not required.

Thermostat Testing Procedure

NOTICE: This procedure will take time to do properly. Refer to Fig. 7.

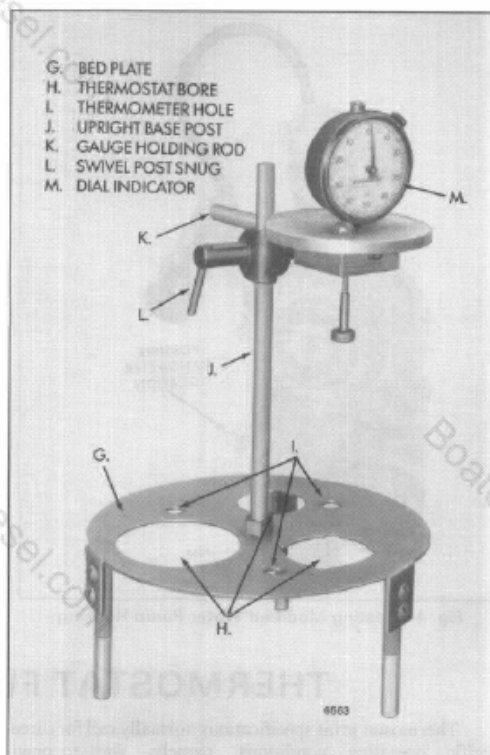

Fig. 5 - Test Plate Assembly

Place the vessel on a level surface and lower the bed plate into position, being careful to avoid contact with the heating element.

Fully submerge the thermostat in warm water and place a laboratory thermometer in one of the 7/16" holes on the bed plate. Position the dial indicator over the thermostat, centering the contact point on the motor mechanism. Zero the dial. To ensure accurate test results, allow the thermostat to warm up to water temperature before testing. Then, turn on the heating element (if necessary) and bring water temperature to a few degrees below the start-to-open temperature of the thermostat being tested. Hold at this temperature for 2-3 minutes.

With the heating element on, adjust the air valve to sufficiently agitate the water for equal heat distribution. Bring bath temperature up to the maximum specified start-to-open temperature of the thermostat. Observe the dial indicator and note the temperature at which the needle just begins to move. This is referred to as the *start-to-open temperature*. The total indicator travel, from start-to-open to full-open is referred to as the *full open travel*.

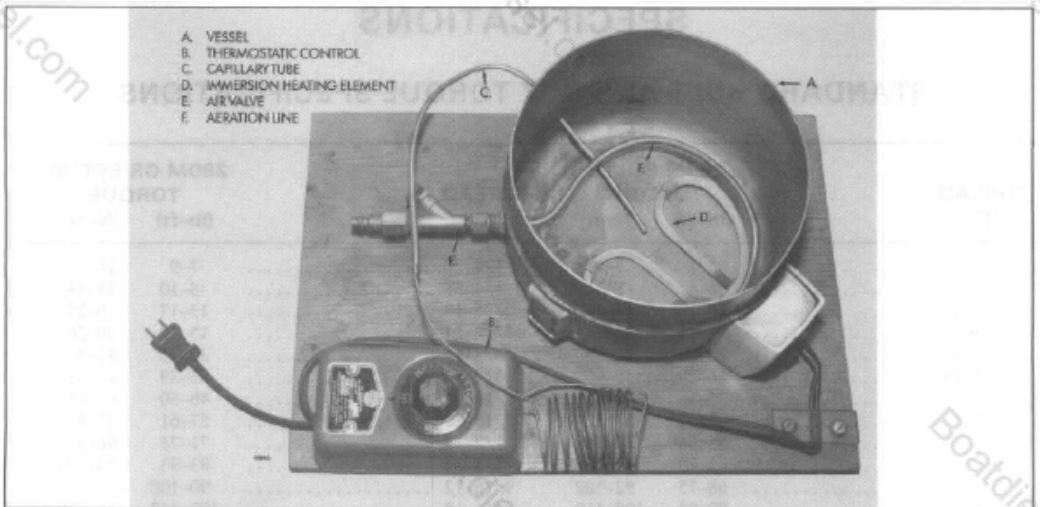

Fig. 6 - Test Vessel and Control

For full-open temperature and travel, raise bath temperature a few degrees above the specified full-open temperature and hold at that temperature for 2 to 3 minutes.

To efficiently test a number of thermostats, simply add cold water to the vessel. This will reduce the water temperature to a level below the next thermostat opening temperature, thus saving time. Turn the heating element off after completing the tests.

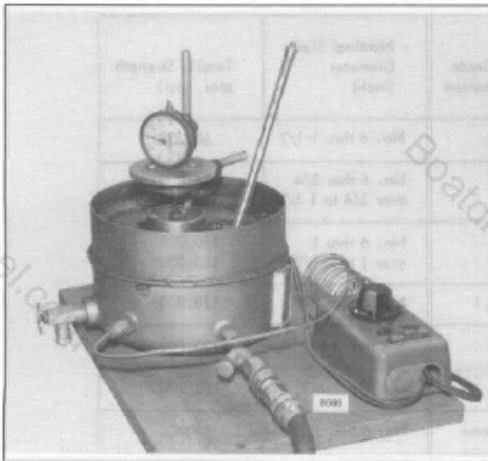

Fig. 7 - Testing a Thermostat in the Test Fixture

Conducting Cooling Tests

When conducting cooling tests on an engine, it is essential that maximum radiator/heat exchanger coolant flow be achieved. Coolant flow and, subsequently, the accuracy of cooling system test results depend to a large extent on the condition of the thermostat installation. If maximum flow does not occur, check for these causes:

1. Thermostat(s) not blocked open to correct dimension.
2. Thermostat housing seal(s) missing.
3. Thermostat housing seal(s) worn.
4. Thermostat housing cover bypass cavity sealing surface(s) not centered and/or worn.

Find Coolant Leaks with Fluorescent Dye, Black Light

Finding the source of an engine coolant leak is often a time-consuming affair. To speed the process, a fluorescent dye such as 15174 *Uranine* (or equivalent) may be added to the coolant. Under an ultraviolet "black light," the *Uranine* dye-treated coolant turns a highly visible, bright yellow-green color, making the leak path easy to trace.

15174 *Uranine* is manufactured by Chemcentral Corporation and is available through their distributor network. For further information contact:





CHEMCENTRAL CORPORATION
 7050 West 71st Street
 Chicago, Illinois 60638

SPECIFICATIONS

STANDARD BOLT AND NUT TORQUE SPECIFICATIONS

THREAD SIZE	260M BOLTS TORQUE		THREAD SIZE	280M OR BETTER TORQUE	
	(lb-ft)	Nom		(lb-ft)	Nom
1/4-20	5-7	7-9	1/4-20	7-9	10-12
1/4-28	6-8	8-11	1/4-28	8-10	11-14
5/16-18	10-13	14-18	5/16-18	13-17	18-23
5/16-24	11-14	15-19	5/16-24	15-19	20-26
3/8-16	23-26	31-35	3/8-16	30-35	41-47
3/8-24	26-29	35-40	3/8-24	35-39	47-53
7/16-14	35-38	47-51	7/16-14	46-50	62-68
7/16-20	43-46	58-62	7/16-20	57-61	77-83
1/2-13	53-56	72-76	1/2-13	71-75	96-102
1/2-20	62-70	84-95	1/2-20	83-93	113-126
9/16-12	68-75	92-102	9/16-12	90-100	122-136
9/16-18	80-88	109-119	9/16-18	107-117	146-159
5/8-11	103-110	140-149	5/8-11	137-147	186-200
5/8-18	126-134	171-181	5/8-18	168-178	228-242
3/4-10	180-188	244-254	3/4-10	240-250	325-339
3/4-16	218-225	295-305	3/4-16	290-300	393-407
7/8-9	308-315	417-427	7/8-9	410-420	556-569
7/8-14	356-364	483-494	7/8-14	475-485	644-657
1-8	435-443	590-600	1-8	580-590	786-800
1-14	514-521	697-705	1-14	685-695	928-942

Grade identification markings are normally stamped on the heads of the bolts. To aid identification of the various bolts used in Detroit Diesel engines, refer to the following chart.

Grade Identification Marking on Bolt Head	GM Number	SAE Grade Designation	Nominal Size Diameter (inch)	Tensile Strength Min. (psi)
None	GM 255-M	1	No. 6 thru 1 1/2	60,000
None	GM 260-M	2	No. 6 thru 3/4 over 3/4 to 1 1/2	74,000 60,000
 Bolts and Screws	GM 280-M	5	No. 6 thru 1 over 1 to 1 1/2	120,000 105,000
 Hex Head Sems Only	GM 275-M	5.1	No. 6 thru 3/8	120,000
 Bolts and Screws	GM 290-M	7	1/4 thru 1 1/2	133,000
 Bolts and Screws	GM 300-M	8	1/4 thru 1 1/2	150,000
 Bolts and Screws	GM 455-M	None	No. 6 thru 1 1/2	55,000

BOLT IDENTIFICATION CHART

12252

EXCEPTIONS TO STANDARD BOLT AND NUT TORQUE SPECIFICATIONS

APPLICATION	THREAD	lb-ft	Nm
Water outlet cover plate bolt	3/8-16	20-25	27-34
Water manifold nut	3/8-24	20-25	27-34
Water pump impeller retaining nut	7/16-20	35-40	47-54

STUD TORQUE SPECIFICATIONS

APPLICATION	lb-ft	Nm
Water pump body stud (16V)	10-20	14-27
Water pump over stud (16V)	12-15	16-20

SERVICE TOOLS

TOOL NAME	TOOL NO.
Cooling system and radiator cap pressure tester	J 24460-01
Fingers, fan hub nut socket (16V)	J 6534-8
Handle	J 7079-2
Oil seal installer	J 8501
Pliers	J 4646
Puller	J 24420-A
Socket, fan hub nut (16V)	J 22556-2
Thermostat seal installer	J 8550
Water pump bearing and gear installer	J 25257
Water pump impeller/gear slip torque tool	J 33765
Water pump seal remover set	J 22150-B
Water pump impeller slip checking fixture	J 34034