



List of Illustrations

Fig. No.	Title	
1-1	Federal Certification Label	1-6
1-2	Identification Plates	1-6
2-1	Pilot/Co-Pilot Compartment	2-1
2-2	Lower Dash	2-2
2-3	"The Horn"	2-5
2-4	Pilot's Area Overhead Dash	2-7
2-5	Digital Clock/Elapsed Time Display	2-8
2-6	Pilot's Left Overhead Control Panel	2-9
2-7	Co-Pilot's Area Overhead Dash	2-10
2-8	Leveling Jack Controls	2-10
2-9	Steering Column Area Controls	2-11
2-10	Transmission Gear Selector Console	2-12
2-11	Radar Detector	2-14
2-12	Seat Controls	2-15
2-13	AM/FM Stereo Tuner/Cassette Player	2-16
2-14	CCTV Camera Port	2-20
2-15	Extendable TV Antenna Radome	2-20
2-16	Antenna Control Panel	2-21
2-17	CB Transceiver Unit	2-21
3-1	Vacuum Cleaner System	3-1
3-2	Dinette Area	3-1
3-3	Galley Facilities	3-2
3-4	Refrigerator Operating Controls	3-2
3-5	Gas Range and Oven	3-4
3-6	Food Center	3-5
3-7	Shower Stall	3-5
3-8	Toilet	3-6
3-9	Lighted Vent/Exhaust Fan	3-6
3-10	Exhaust Fan Control Panel	3-6
3-11	Bathroom Shower and Kitchen Vent/Exhaust Fan	3-6
3-12	Heater Thermostat	3-7
3-13	Air Conditioner Controls	3-10
3-14	Systems Monitoring and Control Panel	3-10
3-15	The Thermometer and The Clock	3-11
3-16	Tank Monitor Panel	3-11
3-17	Gas/Smoke Alarm	3-12
3-18	AC Voltage Monitor	3-12
3-19	Waste Odor Control Panel	3-13
3-20	Digitell Control Center	3-13
3-21	Generator Switch	3-14
3-22	Switch and Monitor Panel	3-14
3-23	LP Gas Leakage Detector	3-14
3-24	Electronic Door Chime	3-15
3-25	Portable Oscillating Fan	3-15
3-26	Security Timer	3-15
3-27	Intercom System	3-16
4-1	Typical Load Center	4-1
4-2	Battery Compartment	4-1
4-3	Stepwell Compartment	4-2
4-4	Load Center Circuit Breakers	4-3
4-5	Generator Tray	4-3
5-1	Location of Commercial Water Hookup	5-1
5-2	Water Purge Air Pressure, Water Heater Drain and Water Tank Drain Controls	5-2
5-3	Water Pump Location	5-3
5-4	Location of Holding Tanks Drain Valve	5-4
5-5	Lavatory Plumbing	5-4
6-1	LPG Tank Compartment	6-1
6-2	LPG Low Pressure Distribution	6-2
8-1	Locating Jack	8-4
8-2	Lug Nut Tightening Pattern	8-5
8-3	Mountz Power Wrench	8-6
8-4	Racor Filter/Separator	8-8
8-5	Generator Unit, Tray Extended	8-12
8-6	Generator Air Cleaner	8-13
8-7	Refrigerator Gas Burner	8-15
8-8	Tub/Shower Mixing Valve	8-17
10-1	Chassis and Water Heater Circuits	
10-2	12 Volt Diagram, Lower Front Load Center	
10-3	12 Volt Diagram, Overhead Front Load Center	
10-4	12 Volt Diagram, Left Front Load Center (Sheet 1 & 2)	
10-5	12 Volt Diagram, Right Front Load Center (Sheet 1 & 2)	
10-6	12 Volt Diagram, Left Rear Load Center (Sheet 1 & 2)	
10-7	12 Volt Diagram, Right Rear Load Center (Sheet 1 & 2)	
10-8	12 Volt Diagram, Batteries and Charging Circuits	
10-9	Diagram, Wiring Blaupunkt Stereo	
10-10	Potable Water System	
10-11	Drainage System	
10-12	Liquid Petroleum Gas System	
10-13	Air System (sheet one)	
10-13	Air System (sheet two)	
10-14	Chassis Lubrication Guide	



11-1	Awning Opening Procedure	11-1
11-2	Awning Opening Procedure	11-1
11-3	Awning Opening Procedure	11-1
11-4	Awning Opening Procedure	11-2
11-5	Ice-Maker Details	11-4
11-6	Microwave/Convection Oven Control Panel	11-5



List of Illustrations

Fig. No.	Title	
1-1	Federal Certification Label	1-6
1-2	Identification Plates	1-6
2-1	Pilot/Co-Pilot Compartment	2-1
2-2	Lower Dash	2-2
2-3	"The Horn"	2-5
2-4	Pilot's Area Overhead Dash	2-7
2-5	Digital Clock/Elapsed Time Display	2-8
2-6	Pilot's Left Overhead Control Panel	2-9
2-7	Co-Pilot's Area Overhead Dash	2-10
2-8	Leveling Jack Controls	2-10
2-9	Steering Column Area Controls	2-11
2-10	Transmission Gear Selector Console	2-12
2-11	Radar Detector	2-14
2-12	Seat Controls	2-15
2-13	AM/FM Stereo Tuner/Cassette Player	2-16
2-14	CCTV Camera Port	2-20
2-15	Extendable TV Antenna Radome	2-20
2-16	Antenna Control Panel	2-21
2-17	CB Transceiver Unit	2-21
3-1	Vacuum Cleaner System	3-1
3-2	Dinette Area	3-1
3-3	Galley Facilities	3-2
3-4	Refrigerator Operating Controls	3-2
3-5	Gas Range and Oven	3-4
3-6	Food Center	3-5
3-7	Shower Stall	3-5
3-8	Toilet	3-6
3-9	Lighted Vent/Exhaust Fan	3-6
3-10	Exhaust Fan Control Panel	3-6
3-11	Bathroom Shower and Kitchen Vent/Exhaust Fan	3-6
3-12	Heater Thermostat	3-7
3-13	Air Conditioner Controls	3-10
3-14	Systems Monitoring and Control Panel	3-10
3-15	The Thermometer and The Clock	3-11
3-16	Tank Monitor Panel	3-11
3-17	Gas/Smoke Alarm	3-12
3-18	AC Voltage Monitor	3-12
3-19	Waste Odor Control Panel	3-13
3-20	Digitell Control Center	3-13
3-21	Generator Switch	3-14
3-22	Switch and Monitor Panel	3-14
3-23	LP Gas Leakage Detector	3-14
3-24	Electronic Door Chime	3-15
3-25	Portable Oscillating Fan	3-15
3-26	Security Timer	3-15
3-27	Intercom System	3-16
4-1	Typical Load Center	4-1
4-2	Battery Compartment	4-1
4-3	Stepwell Compartment	4-2
4-4	Load Center Circuit Breakers	4-3
4-5	Generator Tray	4-3
5-1	Location of Commercial Water Hookup	5-1
5-2	Water Purge Air Pressure, Water Heater Drain and Water Tank Drain Controls	5-1
5-3	Water Pump Location	5-3
5-4	Location of Holding Tanks Drain Valve	5-4
5-5	Lavatory Plumbing	5-4
6-1	LPG Tank Compartment	6-1
6-2	LPG Low Pressure Distribution	6-2
8-1	Locating Jack	8-4
8-2	Lug Nut Tightening Pattern	8-5
8-3	Mountz Power Wrench	8-6
8-4	Racor Filter/Separator	8-8
8-5	Generator Unit, Tray Extended	8-12
8-6	Generator Air Cleaner	8-13
8-7	Refrigerator Gas Burner	8-15
8-8	Tub/Shower Mixing Valve	8-17
10-1	Chassis and Water Heater Circuits	
10-2	12 Volt Diagram, Lower Front Load Center	
10-3	12 Volt Diagram, Overhead Front Load Center	
10-4	12 Volt Diagram, Left Front Load Center (Sheet 1 & 2)	
10-5	12 Volt Diagram, Right Front Load Center (Sheet 1 & 2)	
10-6	12 Volt Diagram, Left Rear Load Center (Sheet 1 & 2)	
10-7	12 Volt Diagram, Right Rear Load Center (Sheet 1 & 2)	
10-8	12 Volt Diagram, Batteries and Charging Circuits	
10-9	Diagram, Wiring Blaupunkt Stereo	
10-10	Potable Water System	
10-11	Drainage System	
10-12	Liquid Petroleum Gas System	
10-13	Air System (sheet one)	
10-13	Air System (sheet two)	
10-14	Chassis Lubrication Guide	



11-1	Awning Opening Procedure	11-1
11-2	Awning Opening Procedure	11-1
11-3	Awning Opening Procedure	11-1
11-4	Awning Opening Procedure	11-2
11-5	Ice-Maker Details	11-4
11-6	Microwave/Convection Oven Control Panel	11-5



List of Tables

Table No.	Title	
4-1	Electrical Ratings for Motorhome Appliances	4-4
8-1	Engine and Chassis Specifications ...	8-1
8-2	Engine/Chassis Capacities	8-1
8-3	Generator Capacities and Specifications	8-2
8-4	Motorhome Capacities and Specifications	8-2
8-5	Maintenance Schedule Summary	8-2
8-6	12-Volt Light Equipment, and Fuses, Current Usage	8-3
8-7	Generator Maintenance Schedule ...	8-11
8-8	Anti-Freeze Protection Chart	8-14
8-9	Water Pump Troubleshooting Guide .	8-16



Handwritten text, possibly a title or header.

Main body of handwritten text, appearing to be a list or detailed notes.



Microwave Utensils	11-6
Convection Cooking	11-6
Convection Utensils	11-7
Mountz Power Wrench	11-7
Konstant Hot Water Dispenser	11-7
Kool-O-Matic Ventilation Fan	11-7
Operation	11-7
Redi-Line Motor Generator	11-7
Auxiliary Air Compressor	11-7
Operation	11-8
Maintenance	11-8
CORIAN Counter Tops	11-8
Water System Air Accumulator with Diaphragm	11-8



Section I

Introduction

This section of your Owner's Manual contains general hints and recommendations for using your motorhome. Checklists and suggestions are offered which cover just about every phase of motorhome travel.

The remaining sections of this manual, Sections II through XI, describe in detail the operation and use of the individual items and systems which comprise your motorhome. The following paragraphs summarize the contents of these sections:

Section II Operation — Covers driver's instrumentation, operating controls, gauges and indicators.

General data on operation of coach vehicular systems are also covered in this section.

Section III Living Area Facilities — Covers operation of heating and air conditioning systems, use of accessories and appliances and related general coach facilities data.

Section IV Electrical Systems — This section describes operation of coach electrical systems; ac/dc operation and generator switching are also covered.

Section V Water Distribution and Drainage Systems — Covers internal supply and distribution, plumbing, city water hookups, tank fill and sanitizing, holding tank dumping and operation of hot water supply system.

Section VI LPG System — This section describes LPG internal supply and distribution, tank filling procedures, system component locations, and precautions to observe regarding LPG handling.

Section VII Air Brake Systems — This section covers operation of the service brakes and spring brake systems, fail/safe features and general brakes system operation.

Section VIII Owner Maintenance Data —

Includes information on maintenance procedures which may be within the scope of the owner. Coverage is provided for preventive maintenance schedules, specifications and system capacities, cold weather operation, storage and winterizing.

Interior/exterior appearance care and emergency maintenance procedures are also described.

Section IX General Information — A list of major components, including model numbers, name and address of manufacturer.

Section X Diagrams — Contains wiring, schematic, piping and general-purpose diagrams to assist in troubleshooting and understanding how these systems function.

Section XI Optional Equipment — This section provides you with information on optional equipment and features used in your motorhome.

We hope that this manual will help answer any questions that may arise about the use, operation and maintenance of your motorhome. Any suggestions or recommendations that you might have for including or expanding on material of interest will be carefully considered for incorporation in periodic supplements. We are always interested in providing our coach owners with the most current and comprehensive information about our product.

Your satisfaction is our assurance that we are fulfilling our responsibilities to our owners.



Checklists

A little preliminary planning will go a long way to help make your trips successful and enjoyable. As an aid to planning your travels, review the following checklists. If there are any additional items that you should be reminded of, add them where you see fit. These lists are only recommendations based on the experience and suggestions of sources well-versed in motor-coach expertise. You will eventually find that a short "walk-around" the coach, outside and inside, will be adequate and comprehensive enough to ensure that you're ready for travel.

Before You Leave:

- Store valuables and important papers in a safe place.
- Arrange care for your pets.
- Cover all food to keep out mice and insects.
- Store oil, gasoline, matches and other inflammables properly; get rid of newspapers, magazines and oily rags.
- Connect timers to several inside lamps and outside lights; keep some shades open for a lived-in look.
- Discontinue newspaper, milk and other deliveries; store trash cans and outside equipment.
- If weather permits, shut down hot water and heating systems; close main water supply.
- Ask the Post Office to hold your mail.
- Have your lawn, garden and house plants cared for.
- Arrange with the Telephone Company for discontinued or "Vacation Service".
- Lock all windows and doors securely.
- Leave your key with your neighbor; let him know your basic itinerary.
- Notify police.

Checkout Your Coach — Outside:

- Disconnect and stow:
 1. Electrical cord.
 2. Sewer hose (flush out)
 3. Water hose.
- Check all exterior lights for damage.
- Check wheel lug nuts for tightness. (450-500 ft.-lb.)
- Check tires for correct pressure. (See Table 8-1).
- Check that all external compartments and filler openings are properly closed and/or locked.

- Check that items stored on exterior of coach are secured. (Be sure that these items present no clearance problems.)

Note

If the trip you are planning will take the coach well past suggested maintenance intervals listed in Section VIII, it may be advisable to perform these procedures before leaving. This may avoid unscheduled stops or interruptions during your trip.

- Check that there are no obstacles to avoid above or under the coach. Be sure that there is sufficient clearance front and rear.

Checkout Your Coach — Inside:

- Turn off water pump switches.
- Close windows and vents.
- Check that cabinet doors and drawers are secured.
- Check that refrigerator door latch is in locked position.
- Check that no heavy item is stored in an overhead cabinet.
- Store large items in base cabinets.
- Check that counter tops, range top, table tops and shelves are clear of unsecured items.
- Turn off interior lights; check that entrance step is retracted.
- Secure and lock the entrance door.
- Adjust exterior and interior mirrors.

Warning

Mirrors provide needed additional driver visibility. To be effectively used mirrors must be properly adjusted for each driver and the driver must be aware of the limitations on viewing area that exist even when mirrors are properly used.

Check Your Automotive Systems:

- Check that fluid levels are normal (oil, power steering, engine coolant, battery electrolyte, windshield washers, transmission, etc.).
- Check generator oil level, coolant level, battery condition.
- Check operation of turn signals, emergency flasher, stoplights and backup lights.
- Check that headlight high- and low-beams oper-



ate.

- Check horn operation.
- Check fuel gauge, and top up fuel tank.
- Start engine and check gauges for signs of trouble.
- Check operation of foot brakes, emergency brake. (See that brake pressure builds up and steadies at about 100 to 120 psi.)

And, Before Driving Away:

- Check operation of appliances and special equipment.
- Check that fire extinguishers are fully charged.
- Check operation of interior and exterior lighting.
- Start generator and check 120v ac system and wall outlets.
- Adjust driver's seat so that all controls are within easy reach.
- Make sure that seat is locked in position. Do not adjust driver's seat swivel or foreaft mechanism while vehicle is moving or seat could move unexpectedly, causing a loss of control.
- Check that front passenger's seat is locked in position.
- Fasten seat belts. Belts should be placed as low as possible around the hips. This places the load of the body on the strong hip bone structure instead of around the soft abdominal area and prevents sliding out in case of an accident.
- Check that warning lights are lit when the ignition key is turned to **on** or **start** position.

Some Items You Might Want to Take Along On Your Trip

Note

You may find that many items taken were not needed and that some items that were needed were overlooked during planning of your last trip. Make notes of these items to prevent duplicating the same errors.

- Adequate supply of prescription medicines.
- Prescription sunglasses or reading glasses.
- Camera equipment and film supply.
- Heating pads, ice bags, etc.
- Stationery, envelopes, stamps.
- Telephone number list.
- Reading material.
- Special pet supplies.
- Extra toilet chemical and toilet articles.
- Spare belts for engine-operated equipment.

- Spare parts for generator: suggested spares include oil filter, fuel pump, air filter, solenoid. Five quarts of approved motor oil.
- A professional-type double-action tire pressure gauge.
- Under the heading of **Emergency Equipment**, it is advisable to consider outfitting your coach with these items:

1. First aid-kit
2. Emergency highway flares
3. Flashlight or lantern (with extra batteries)
4. Tool kit
5. Replacement lamp assortment
6. Replacement fuse assortment
7. A trouble light with a long cord

And Some Other Thoughts To Consider

- Automobile insurance to cover you and your family.
- Avoid cash. Use traveler's checks and credit cards wherever possible.
- Confirm reservations well in advance of arrival.
- Make a clothing check list for everyone.

Citizen's Band Transceiver

You might also bear in mind that your coach is equipped with a CB unit (Citizen's Band receiver-transmitter). In the event of an emergency situation which requires outside assistance, remember to call for help on Channel 9. This channel is restricted to emergency use only and it is monitored 24 hours per day! Don't hesitate to use your CB if you see someone else in need of assistance.

Hot Weather Operation

Wherever possible, choose a shaded parking site so that the coach will be cooler during the hottest part of the day. The full-length side awning will be especially useful in lowering inside temperature. Air conditioning units are indispensable in hot climates. Keep in mind that their proper operation depends on adequate line voltage. Low voltage causes motors to run hotter and reduces compressor motor life. Supply voltage in some campgrounds may not be as high as necessary, especially when there are heavy loads on the lines from other air conditioners. Check the wall-mounted monitors when in doubt.



Cold Weather Operation

LPG appliances, furnace, and gas refrigerator are designed with sealed combustion areas. This is for your protection to prevent danger from carbon monoxide or depletion of oxygen. Your motorhome is equipped with a highly accurate and sensitive gas/smoke alarm. Heed alarm indications!

If frost or condensation accumulates in closets or cabinets during long periods of cold weather operation, leave the doors to these areas slightly ajar to provide air circulation. Be sure that roof vents are open when using oven or burners.

Campground Courtesy

Don't forget the "Golden Rule". Being considerate of your neighbors will help make friends. A few of the "Do's" and "Don'ts" are:

- Good housekeeping — put all litter in the proper receptacles and leave your site neat and clean.
- Don't allow your water or sewer hook-ups to leak.
- Respect your neighbor's desire to retire at an early hour. Avoid loud noises and bright lights after dark.
- Drive slowly through camp areas at any hour for the safety of pedestrians.

Insurance

As with your automobile, it is important that you have adequate protection with insurance coverages for personal liability, theft, collision, overturn, property damage, etc.

Canadian and Mexican Insurance

Insurance for travel in Canada can usually be covered by your present U.S. policy for the recreational vehicle, often at no extra cost. Consult your individual company for procedures and be sure of your coverage before entry.

For travel in Mexico (at the present time) there are no U.S. insurance companies that can provide recognized Mexican coverage, with the exception of that required for travel through a narrow strip of Mexican territory in and around ports of entry and the U.S./Mexican border.

Mexican insurance is controlled, and rates are set, by the Mexican government. There are several reliable companies handling Mexican insur-

ance, with similar rates for the necessary coverages. The principal differences between them are the "fringe benefits", received in the form of informational travelogs and other helpful information, such as dining places considered acceptable for sanitary conditions, fuel stations, and so on.

Some insurance services include detailed route maps with "where to stay" recommendations and "things to see" mile-by-mile (or kilometer-by-kilometer post). While the rates set by Mexico may seem quite expensive at first glance, you usually end up not spending quite as much as expected because you can usually arrange to hold your state-side policy in abeyance during the same period you are in Mexico, thus not having to pay unnecessarily for double coverage. In addition, you may be able to obtain substantial refunds on the Mexican collision insurance after your return to the U.S. Be sure to obtain a certification from the park operator at each location in Mexico to certify the dates that your coach was parked there. If your coach is parked for most of the time, instead of constantly traveling, your refund may be a major portion of the original cost. This feature is referred to as the "in-storage" credit. (It is a good idea to always check with your insurance company before taking a trip to find out whether applicable insurance rules and regulations have changed. Keep up to date on your coverage.)

Carry insurance papers at all times!

Safety Considerations

Using LP Gas

Check for leaks at the connections on the LP gas system soon after purchase and initial filling of LP tank; continued periodic checks of the system are recommended. Even though the manufacturer and dealer have already made tests for leakage, this check is advisable because of the vibrations encountered during travel. Apply a soapy water solution to the outside of gas piping connections to find gas leakage (bubbles). Usually, tightening of connections will close leaks. (Be sure to first shut off the gas supply!) If not, ask your authorized dealer service to make the needed repairs.

Liquified Petroleum Gas (LPG) is heavier than air. Leaking gas tends to flow to low places, such as does water. It will sometimes pocket in a low area. LP gas can usually be detected by an identifi-



able odor characteristic to onions or garlic.

Caution

Never light a match or allow any open flame in the presence of leaking gas!

Be sure that the main LP gas supply valve is closed during refueling to prevent accidental ignition of gas fumes by appliance pilot lights.

Your Wanderlodge® has been provided with an automatic 80% fill valve to protect you from the dangers of an overfilled LPG tank.

Electrical Systems

Your coach has been engineered and checked for your complete electrical system safety. Circuit breakers and fuses are installed to protect electrical circuits from overloading. Before making modifications or additions to the electrical system, consult your dealer for assistance in obtaining a safe and secure installation.

Do not "jump" circuit protectors!

Built-In Power Cord Adapter

Approved power supply cords supplied with the coach for hookup to external power sources are listed below:

- | | Identification |
|---|----------------|
| • 50A female to 50A male (1) | Red Tape |
| • 50A female to 30A male (1) | Red Tape |
| • 30A female to 30A male (2) | Yellow Tape |
| • 30A female to 30A male extension(2) | None |
| • 30A female to 20A male adapter (2) | None |

Note that each cord has a ground pin which provides proper electrical system grounding. The ground pin is your personal protection from electrical shock hazards. Do not use any adapter, cheater, or extension cord that will break the continuity of the grounding circuit. **Never** remove the grounding pin for convenience of being able to make a connection to a non-grounded receptacle!

The power cord adapter allows connection of two 30 ampere 120 volt lines (from separate external circuits) to the shoreline plug in the rear of your coach. This will permit use of all motorhome appliances without overloading the supply lines.

Never operate your coach with a "hot skin"! If you can feel even a slight "tingling" shock from touching the coach body while standing outside on the ground, immediately disconnect the electrical hookup until the trouble is located. This fault is usu-

ally caused by a break in the grounding circuit, which should be continuous from the coach skin or frame to the distribution panel board to the third (ground) pin on the power supply cord, and from there to the park receptacle and earth ground. Your motorhome is equipped with dual polarity-protector monitor panels, located on the galley wall. These panels are for your protection in ensuring against improper grounding or reversed hookups. In 1985 and 1986 model coaches, a second dual powerline monitor is located in the shoreline/utility box.

Emergency Stops

Always carry road flares and/or reflective triangular highway warning markers for emergency warning display. Pull off the roadway as far as possible when changing flats or for other emergency situations. Turn on your hazard warning flashers when parked alongside a roadway, even if only for a short while. Have your coach occupants leave the vehicle and stand clear of the area when parked on the edge of a highway.

Engine Exhaust Gas

Avoid inhaling exhaust gases because they contain carbon monoxide, which by itself is colorless and odorless. Carbon monoxide is a dangerous gas that can cause unconsciousness and is potentially lethal. If at any time you suspect that any exhaust fumes are entering the passenger compartment, have the cause determined and corrected as soon as possible.

The best protection against carbon monoxide entry into the vehicle body is a properly maintained engine exhaust system, body and ventilation system. It is a good practice to have the exhaust system and body inspected by a competent mechanic each time the vehicle is raised for lubrication or oil change. It should also be inspected whenever a change is noticed in the sound of the exhaust system and if the exhaust system, underbody or rear of the vehicle has been damaged.

To allow proper operation of the vehicle's ventilation system, keep ventilation inlets clear of snow, leaves, or other obstructions.

Sitting in a parked vehicle with the engine on for extended periods, without proper ventilation, is not recommended!



More Safety Considerations

- Sanitize fresh water supply system periodically. See Section V.
- Prevent water connection fittings from contacting the ground or drain hose to reduce chances of contamination.
- Consider using a qualified technician for repairing gas or electrical appliances.
- Check fire extinguishers periodically for proper charge.
- Avoid overloading your vehicle.
- Be careful not to cause an improper load distribution which can adversely affect roadability.
- Insure that tires are in good condition and properly inflated at all times. Under-inflated tires overheat and are blowout-prone!
- Check and tighten wheel lug nuts every 1,000 miles (torque to 450-300 ft-lbs.)
- Check brake operation in a safe area — not while traveling on a busy highway!
- Use seat belts!

Emergency Exits

Sliding windows, which can be easily opened, may be used as an emergency exit. Squeeze the screen latch and slide it to the rear enough for access to the window latch. Squeeze the window latch and slide window open. Emergency exit windows are identified by an **EXIT** decal on the glass.

Vehicle Loading

Weight Distribution and Load Rating

The Federal Certification Label, located inside and above the drivers windshield between the sunvisor mounting brackets describes the maximum weight-carrying capacities of your motorhome and for each axle, respectively abbreviated by "GVWR" and "GAWR". A typical identification plate is shown in figure 1-1.

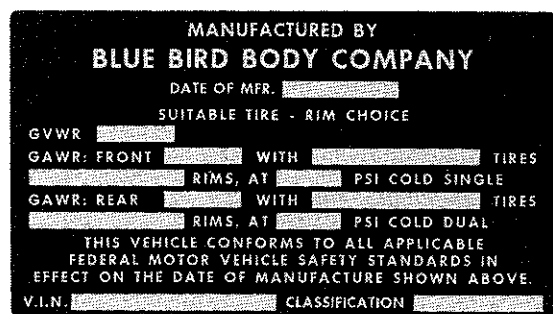

Figure 1-1. Federal Certification Label

The Gross Vehicle Weight Rating (GVWR) is the maximum motorhome weight allowable with all systems filled and with passengers and supplies aboard.

Each axle also has a maximum load-bearing capacity referred to as the Gross Axle Weight Rating (GAWR).

A typical motorhome rating might be as follows:

GVWR	34,000 lbs
GAWR (front)	13,200 lbs
GAWR (rear)	23,000 lbs

Generally, a 31-foot unit will weigh about 27,500 pounds; a 33-foot unit will weigh about 28,500 pounds; and a 35-foot unit will weigh about 29,500 pounds. If optional equipment is installed, add the weight of these items to determine the total weight.

The load capacity is the difference between the GVWR and the actual weight. This means the total weight of all food, clothing, other supplies and passengers, must not exceed the load capacity.

To find the actual weight, with the motorhome fully loaded, drive to a scale and read the weight on the front and on the rear wheels, separately, to determine axle loading. The load on each axle should not exceed its GAWR. If weight ratings are exceeded, move or remove items to bring all weights below the ratings.

Additional data plates located on the back of the stepwell compartment door provide information useful for identifying your coach if you are planning on ordering parts. Identification plates, figure 1-2, provide information such as:

1. Body Serial Number
2. Chassis Serial Number
3. Model Year
4. Model Number of Axle (if axle parts are to be ordered)

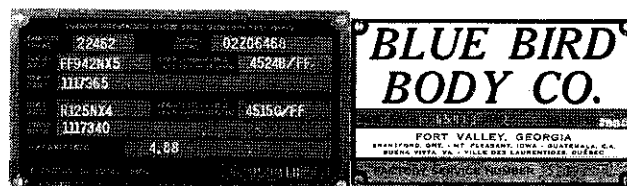

Figure 1-2. Identification Plates



When loading your motorhome, store heavy gear first, keeping it on or as close to the floor as possible. Heavy items should be stored centrally so as to distribute the weight more or less evenly between the front and the rear axles. Store only light objects on high shelves. Distribute weight to obtain even side-to-side balance of the loaded unit. Secure loose items to prevent weight shifts that could adversely affect the balance and roadability of the vehicle.

Economical Driving

How you drive, where you drive and when you drive — these factors all have an effect on determining how many miles you can get from a gallon of fuel. The careful attention you give your vehicle, as far as maintenance and repairs are concerned, will also contribute to fuel economy.

Engine Operating Hints

It is recommended that you use Number 2 diesel fuel for your engine. To locate the closest Caterpillar dealer or other authorized repair shop, call toll free (800) 447-4986 except in Illinois call (309) 673-3252.

Stop-And-Start Driving

Frequent stops and starts during a trip diminish miles per gallon. Plan even short shopping trips so you can take advantage of through-streets to avoid the traffic lights. Pace your driving like the professional drivers to avoid unnecessary stops.

Excessive Idling

An idling engine also consumes fuel. If you are faced with more than a few minutes wait, and you are not in traffic, it may be advisable to shut off the engine and re-start later on.

Lubrication and Maintenance

A properly lubricated vehicle means less friction between moving parts. Consult the maintenance schedules in Section VIII for proper lubricants, lubrication intervals and general coach maintenance scheduling.

Air Cleaner

The mixture of fuel and air which powers the engine is taken into the system through the air cleaner. Replace the air cleaner at required intervals to maintain peak engine efficiency.

Excess Weight

Fuel economy is also related directly to the amount of work accomplished by the engine. Heavier loads require more power. Keep excess weight to a minimum.

Tire Inflation

Under-inflation causes needless tire wear and promotes excess fuel consumption. Check tire pressures on a regular basis.

The Federal Certification Label, figure 1-1, shows the cold tire inflation pressures necessary to support the Gross Axle Weight Ratings.

These pressures can be reduced to greatly improve the ride qualities after the actual axle weights have been determined (see previous section on Vehicle Loading).

A Michelin Tire Data Book is included in your Owner's Kit. In the Specifications — Truck Tires (tubeless) section can be found the recommended tire inflation pressures for various axle weights and tire sizes. If any axle weight is on the borderline, always use the higher pressure.

In addition, a tire inflation information plate is located on the inside of the stepwell compartment door, figure 4-3. These are **normal** pressures as long as the axle weights are not in excess of those shown.

Traveling in Your Motorhome

Overnight Stops

There are many modern recreational vehicle parks with good facilities, including State, County and Federal Parks, where electrical, water and sewer connections are readily available. Directories are published which describe these parks in detail and list available services and hookups.

On overnight or short weekend trips, your motorhome has more than adequate holding tanks and water supply capacity in the event that campgrounds or parking sites are not equipped with these facilities.

On longer trips, where sewer connections and utility hookups are unavailable, it will be necessary to stop from time to time to dispose of holding tank wastes and replenish the water supply. Many gas stations (chain and individually-owned) have in-



stalled sanitary dumping stations for just this purpose.

When stopping for the night, park the coach in a location that is relatively level and where the ground is firm. This will ensure your comfort as well as the leveling of your refrigerator (for most efficient operation).

Extended Stays

Making a long trip is not very different from making a weekend excursion since everything you need is right at hand and you are home wherever you travel. When packing for an extended trip, try to avoid taking non-essential items.

When planning to stay in the same location for several days, weeks, or even months, be sure to maintain the motorhome level. Use leveling jacks system controls for this purpose.

Hook up to the water supply by attaching the water hose to the commercial water supply inlet.

Plug the electrical cable into the shoreline receptacle. Be sure to observe all grounding and connection precautions!

Connect sewage hookup into the disposal facility.

Winter Traveling

Certain precautions should be taken when traveling in your motorhome during the cold winter months. Keep these suggestions in mind:

- Provide heat in the coach at all times.
- Have a plentiful supply of LPG.
- If your stay is longer than overnight, and you do not use the generator, try to have a shoreline hooked up to outside ac power.
- Minimize your use of electricity if 120v ac is unavailable.
- Leave cabinet doors and wardrobe doors slightly open at night to allow for proper air circulation.
- Freeze protection heaters and heat tapes greatly decrease the chances of frozen water lines **provided the coach is plugged into outside power (one 50A. or two 30A. power cords) or the generator is run continuously during cold weather periods.**

Remember that low temperatures in combination with high winds will cause an equivalent chill temperature much below that indicated by your

thermometer. For instance, with an outside temperature of zero degrees, and a wind velocity of 10 miles per hour, the equivalent chill temperature would be -20 degrees F!

There is no substitute for common sense when traveling in cold weather.

General Storage Notes

Drawing draperies will reduce fading of rugs and upholstery. Leaving an air freshener agent will minimize odors from plastics and other materials. Slight opening of windows and vents will allow air circulation without worry of water entering. Covering wheels to eliminate direct rays of the sun on tires will reduce sidewall cracking.

Note

Remove all items from the coach which may freeze, including canned foods, miscellaneous liquids, etc. Remove all contents of the refrigerator/freezer, clean unit and leave doors ajar.



Section II Operation

This section provides information on the operation and function of the controls, indicators and gauges located in the pilot/co-pilot compartment that are used in connection with the coach automotive systems. Figure 2-1 illustrates the pilot/co-pilot compartment, high-lighting the instrumentation and panels covered in this section.

Instrumentation

All essential operating controls and gauges used to monitor and control associated engine, generator and coach systems are located conveniently on and adjacent to the electroluminescent dash panel, figure 2-2.

Associated instrumentation, accessible on the bulkhead above the pilot, includes stereo AM/FM radio/cassette player, TV, generator ON-OFF switch, altimeter and diesel fuel filter monitors. Controls for TV operation are located on the left side bulkhead above the pilot. Refer to figures 2-2 through 2-17 and the following paragraphs for locations and functions of associated operating controls and indicators.



Figure 2-1. Pilot/Co-Pilot Compartment

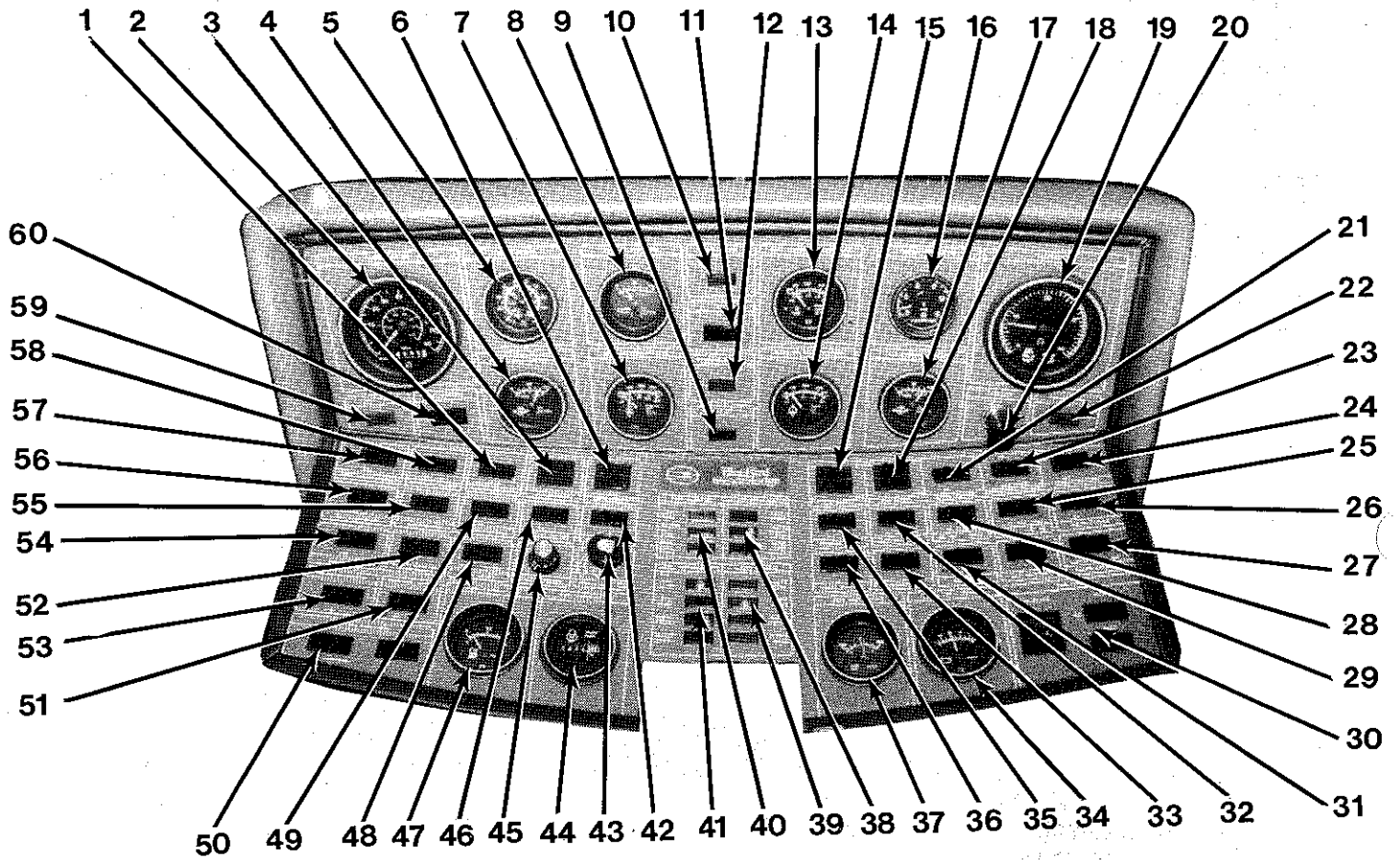

Figure 2-2. Lower Dash



Lower Dash

On the previous page, in figure 2-2, the Lower Dash is shown. Each item on the lower dash is identified by an index number which corresponds to the following description. Some items operate at all times, some require the 12 volt master to be on, while others need the 12 volt master and the ignition on.

*These gauges, require the engine to be at normal operating temperature for correct readings.

① **AUXILIARY STEP** Switch — An **On-Off** switch that, when set to the **EXTENDED** position, activates a relay automatically locking the outside entry step in the out position. The indicator light comes on when the ignition switch is turned on to remind you that you need to retract the step before proceeding.

② **SPEEDOMETER** — Indicates speed and accumulated mileage (odometer). This is a solid-state electronic monitor, with an RPM sensor located at the right drive axle brake drum.

③ **ACCESSORY** Position — These blank positions may be used for the installation of additional switches and indicator lights for customer add on equipment. Also includes items (33), (52), (55), and (60).

Caution

Use existing panel holes for installation of additional controls or indicators. Drilling new holes will destroy the electroluminescent features.

④ **AIR PRESSURE REAR** Gauge &

⑦ **AIR PRESSURE FRONT** Gauge — The Dual Air Service Brake Pressure systems are engine operated and supply independent brake system air pressure for front and rear service brakes and the parking brake. During normal operation, each air pressure gauge reading will build up to 100 psi to 120 psi shortly after the engine is started. Note that, as a safety feature, the parking brake cannot be released until air pressure readings are at least 65 psi.

⑤ * **TURBO BOOST** Gauge — Registers the psi of the Turbo Compressor outlet. The gauge should read a maximum of 21.5 psi at maximum power.

⑥ **ENTRY DOOR** Switches — Dual momentary switches to lock and unlock the entry door. An indicator next to these switches lights when the entry door is unlocked, if the ignition switch is on.

⑦ * **ENG. OIL TEMPERATURE** Gauge — Gives a constant reading of the engine oil in the supply line from the pump. The normal operating temperature is from 200 °F to 250°F. If the temperature goes over 250° the engine may be low on oil or there is overheating of the cooling system.

⑧ * **ENG. OIL PRESSURE** Gauge — Indicates the pressure of the oil, not the amount of oil in the engine reservoir. This gauge will normally read between 40 and 65 psi during cruising speeds; and drop to a minimum of 14 psi when the engine is idling.

Caution

No oil pressure, or low oil pressure readings (below 25 psi) when engine is operating at cruising speeds are trouble indications! Do Not Operate the Engine Under These Conditions!

⑨ **LOW AIR** Warning Indicator — This light is associated with a buzzer. These warn the driver that there is an insufficient supply of air (65 psi or less) to properly operate the coach. If the air pressure is low, when the ignition key is turned on, the light and buzzer will come on immediately. Both warnings will continue until the air pressure is built back up, or the ignition key is turned off.

⑩ **HIGH BEAM** Indicator — Lights when the headlight dimmer floor switch is pressed for High Beam operation and the Headlight switch (43) is on.

⑪ **A/T** Switch — (Anti-Theft) deactivates the starting system for protection against unauthorized cranking and theft.

⑫ **ENGINE ALARM** Indicator — This indicator, along with a Buzzer Alarm, monitors engine operation. If the oil pressure or the coolant level drops too low or if the coolant temperature gets too high, the engine alarm light and buzzer will be activated.

⑬ * **ENG. WATER TEMPERATURE** Gauge — Normal water temperature should be between 180° and 205°F for safe operation.



Caution

If the Engine Temperature gauge indicates excessively high temperatures, the engine may be over-heating and should be stopped to prevent damage. Allow the engine to cool before checking the radiator coolant level.

- ⑭ * **TRANS. OIL TEMPERATURE** Gauge — Monitors and gives constant temperature readings of the transmission oil. If the gauge registers a temperature over the 300°F maximum safety range, check for low fluid in the transmission.
- ⑮ **L.H. WIPER** Dual Switches &
- ⑯ **R.H. WIPER** Dual Switches — The Dual Wiper switches turn the windshield wipers on or off and also control high or low operation. The wipers can be turned on and used individually or both at one time.
- ⑰ * **TURBO PYROMETER** — Registers the temperature of the exhaust gas output of the Turbo. The correct temperature of the exhaust should be around 740°F at maximum power.
- ⑱ **AIR PRESSURE FRONT** Gauge — See item (4).
- ⑲ **R.H. WIPER** — See item (15).
- ⑳ **TACHOMETER** — Indicates actual engine RPM (Revolutions Per Minute) when scale (0-40) reading is multiplied by 100. Idle RPM should be 700 and full load (uphill) 2600 RPM.
- ㉑ **LIGHTER** — Depress to heat the element; pops out when hot.
- ㉒ **L.P. HEAT** Switch — When in the **ON** position, 12v. power is supplied to the L.P.G. furnaces.
- ㉓ **RIGHT TURN** Indicator — When the turn signal lever, (steering column control section), is pushed up into the right turn position this indicator flashes in conjunction with the outside directional lights. The right cornering light will come on continuously if the headlight switch control has been pulled out to either position while the turn signal lever calls for a right turn.

The indicator, along with the left turn indicator and all outside directional lights, flash in unison when the emergency flasher switch on the steering column is pressed in to the on position.

- ㉔ **WINDSHIELD WASHER** Switch — When this switch is held on it provides power to the windshield washer pump to spray a steady stream of water in a vertical pattern from a nozzle mounted on each windshield wiper blade arm. Next to this switch is an indicator that lights when windshield washer fluid is low.
- ㉕ **MIST CONTROL** Switch — When pressed to the **ON** position, will activate the windshield wipers on a delayed time cycle. With both wiper switches **OFF**, press the Mist Control switch to **ON** once and let it return to the center position. This starts the wipers on an approximate 16 second Off-On cycle, which is the longest delay the windshield wipers will take to make one sweep across the windshields. To decrease the delay time between cycles press the Mist Control switch to **ON** again and let it go. Each additional time the switch is pressed **ON** will decrease the delay until the sixth. When the Mist Control switch is pressed **ON** the seventh time, it will revert to the longest delay. Anytime during the cycle, when you want to stop the wipers completely, momentarily press the switch to the far right.
- ㉖ **HEAT** Switch — To turn on the Heater Blower for the co-pilots area press this switch to either the **HI**— or **LOW** position.
- ㉗ **FRONT HEAT** Switch — Activates a solenoid valve to provide engine coolant flow to the front heater core.
- ㉘ **HORN SELECTOR** Switch — Allows selection of the air or electric horns when the steering wheel horn button is depressed.
- ㉙ **HEAT** Switch — To turn on the heater blower for the pilot's area press this switch to either the **HI**— or **LOW** position. Note that when the front heat switch (26) is **OFF**, the heat switches (25) and (28) can be used to provide cool air circulation by turning on the blowers.
- ㉚ **AUX. BATTERY** Switch — When this switch is pressed, a jumper solenoid connects the generator and coach batteries together (in parallel) to provide extra power for cranking the generator or coach. Releasing the switch immediately isolates the two battery systems.
- ㉛ **THE HORN**, Figure 2-3 — This corner of the dash has 3 different switches for use with the musical horn.



The **SELECTOR** switch incorporates 2 thumb-wheels for selecting the tune to be played. Use **The Horn** manual to select a tune. Then set the thumb-wheels to the corresponding numbers or number and letter. Note, that if a tune is playing, making a new selection on the the selector switch will not affect the tune playing.

The **POWER** switch provides power to the musical horn. When this switch is turned **ON** the horn will immediately start playing the tune that corresponds to the digits on the selector switch.

The **PLAY** switch (momentary) resets the horn to the beginning of tune chosen by the Selector switch. If the **PLAY** switch is pressed while a tune is playing, that tune will stop instantly and the horn will reset to the beginning of the tune that corresponds to the digits on the **SELECTOR**.

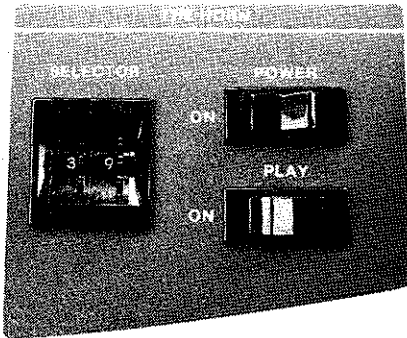

Figure 2-3. "The Horn".

③① **BULK OIL** Switch — When switch is pushed **ON**, 12 volt power is supplied to switch in engine compartment for activation of bulk oil fill system. An indicator lamp next to the switch lights whenever switch is on.

③② **DEFROST** Switch — Turns on the blower for defrosting or defogging the front windshield. Set to **HI**— or **LOW** speed as desired.

③③ **ACCESSORY** Position — See item (3).

③④ **ENG. VOLT METER** — Registers the actual voltage at the coach batteries. With the engine running, gauge should read 14 volts (+ or - 0.5).

③⑤ **MIRROR HEAT** Switch — This switch turns on a thermostatically controlled heater in the right and left outside mirrors (convex mirrors excluded). With the switch **ON** the Mirror Heaters will automatically come on when the mirror temperature drops below 60°.

③⑥ **LEVEL MASTER** Switch — With this switch **ON** power is supplied to the level system (39) and the Level Warning system (41). Leveling jacks can be extended only when the Level Master switch is **ON**.

Caution

Even with all power OFF the leveling jacks can still be retracted. Make sure everyone is clear of the outside of the coach before retracting the jacks.

③⑦ **ENG. AMP. METER** — Shows total charging current in amperes. With the engine running, total alternator output is shown. When parked, with a source of 120 volt ac, (outside power or generator), the gauge will show total output of the battery chargers.

③⑧ **ACCESSORY WARNING** Lights — These three (3) red warning indicators light to alert you of the following conditions:

SUSP. DUMP — Lights to tell you that the suspension system has little or no air, and that the suspension needs to be pressurized before the coach is driven.

GEN. DOOR LOCK — Comes on when the generator compartment is not locked and stays on until the lever is moved to locked position.

HEADLIGHT ALERT — When the ignition switch is turned off and the headlight switch is on, this red warning light, along with a buzzer, will come on. These will remain on until the headlight switch is turned off or the ignition switch is turned back on.

③⑨ **LEVEL SYSTEM** — These blue indicator lights are marked as follows: **LEFT FRONT, LEFT REAR, RIGHT FRONT, and RIGHT REAR**. When the ignition is on the lights come on if the corresponding corner of the coach is not level.

④① **FUEL MONITOR** — Three orange indicators come on when the following conditions are present, and the ignition switch is on:

LOW FUEL — This light comes on when the fuel in the tank is below the 1/4 full mark.

WATER IN FUEL — This light comes on when there is an excess of water in the bottom of the fuel tank.



MAX. FUEL FLOW — Indicates throttle is open as far as needed for maximum power.

④① **LEVEL WARNING SYSTEM** — This system consists of four red indicator lights. These lights come on when the respective leveling jack is not fully retracted. All four lights should be off when the jacks are retracted.

④② **REAR LANDING Light Switch** — At the **ON** position this switch turns **ON** the landing lights in the front right and left panels just behind the front tires. These lights shine toward the rear of the coach so are called Rear Landing Lights. Note that a small blue indicator lights when the switch is **ON**.

④③ **HEADLIGHT Switch** — The Headlight switch serves three functions. Pulling up to the first position (halfway) will turn on the parking lights, and the lights for each gauge in all dash panels. Turn counter-clockwise to increase or clockwise to decrease the brightness of gauge illumination. Pull to the second position (all the way out) and the headlights will come on also.

④④ **ENG. HOUR METER** — This operates whenever the ignition switch is on. The smallest increment is 1/10 hour or six minutes.

④⑤ **DASH DIMMER** — This control will only operate when the headlight switch is on. The background lighting (electroluminescent) for the dash can be brightened by turning counter-clockwise and dimmed by turning clockwise.

④⑥ **FRONT LANDING Light Switch**— To turn on the Front Landing lights, located in the rear side panels just in front of the rear wheels, push this switch to the **ON** position. The indicator next to the switch should be lit when the switch is on.

④⑦ **FUEL LEVEL Gauge** — Indicates the amount of diesel fuel remaining in the tank. This gauge reads only when the ignition switch is in **ON** or **ACCESSORY** position. The fuel gauge used on 31-foot and 33-foot units is a dual-purpose monitor: when the fuel tank gauge selector switch is operated, it can also read the level of gasoline (30 gallons maximum) remaining in the generator fuel tank.

④⑧ **FUEL LEVEL switch location** — Fuel tank gauge selector switch is mounted here on 31 and 33 foot coaches.

④⑨ **REAR PARKING Light Switch** — This switch controls the on-off operation of the rear parking lights (rectangular halogen lights above the rear bumper) when transmission selector lever is in **R**. An indicator next to the switch lights when the rear parking lights are on.

⑤① **CRUISE CONTROL** — These two switches operate in the following manner: The switch on the right turns the cruise control on or off. The switch on the left locks the cruise control in on the desired cruising speed.

Note that the coach must be traveling at least 20 mph before the cruise control will activate. When the desired speed is reached press the **ON-OFF** switch to the **ON** position then press the **SET-RESUME** switch to the **SET** position and hold for 2 seconds before releasing. The coach should automatically remain at that speed.

Note that the accelerator can be used to increase the speed of the coach, but the speed cannot be decreased unless the brake pedal is depressed, or the **ON-OFF** switch is turned **OFF**. If you use the brake to disengage the cruise control, and you would like to pick back up to your original cruising speed, press the **SET-RESUME** switch to the **RESUME** position for 2 seconds. The coach should automatically return to that original speed.

Engine idle speed can be increased, while parked, by means of the cruise control switches. Push the **ON-OFF** switch to **ON**; then push and release **RESUME** switch rocker until desired RPM is attained. RPM will return to normal idle speed when:

1. **CRUISE CONTROL ON-OFF** switch is turned off.
2. Transmission selector is moved from **N** position.
3. Parking brake is released.

Note

Pressing on brake pedal will decrease RPM but speed will return to higher setting as soon as pedal is released.

⑤① **DRIVING LIGHTS Switch** — Driving lights are recessed in the front bumper. When the Driving Light switch is turned **ON**, the Driving Lights and an indicator next to the switch should come on.

⑤② **ACCESSORY Position** — See item (3).



⑤③ **MARKER LIGHTS** Switch — Press this switch to **ON** to turn on the clearance and identification lamps located on the top sides and ends of the coach. This switch may also be flipped on and off to flash the marker lights as a courtesy signal.

⑤④ **RETARDER** Switch — Provides power to Retarder controller mounted on transmission gear selector console. The adjacent indicator lights when switch is **ON**.

⑤⑤ **ACCESSORY** Position — See item (3).

⑤⑥ **FAN OVERRIDE** — This switch operates the engine cooling fan in the engine compartment. The engine cooling fan is thermostatically controlled, and the activating temperature is 195°. To override the thermostat turn the Fan Override switch on, and the engine cooling fan will operate at any temperature continuously.

⑤⑦ **COMP. LIGHT MASTER** Switch — This switch in the **ON** position provides power to all of the exterior compartment light switches. As each compartment door is opened, the light automatically comes on; closing the door turns the light off.

⑤⑧ **BURGLAR ALARM** Switch — There are two switches that turn the Burglar Alarm on and off. The switch on the dash is used when you are inside the coach. The weather proof key switch, outside the coach next to the entrance door, is used when you are going to be leaving your coach for awhile.

Note that both switches operate independently of one another. If the Burglar Alarm is turned on at the dash, then it must be turned off at the dash. The outside switch works on the same principle.

⑤⑨ **LEFT TURN** Indicator — When the turn signal lever is pulled down into the left turn position, this indicator flashes in conjunction with the outside directional lights.

The left cornering light will come on continuously if the headlight switch control has been pulled out to either position while the turn signal lever calls for a left turn.

⑥⑩ **ACCESSORY** Position — See item (3).

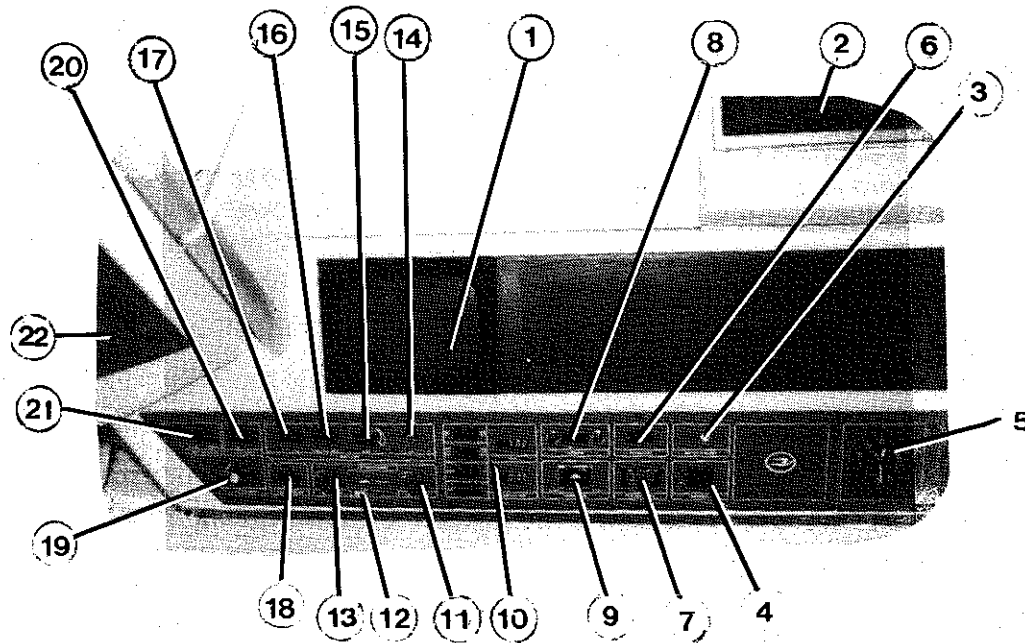

Figure 2-4. Pilot's Area Overhead Dash

Pilot's Area Overhead Dash

The pilot's overhead panel is pictured in figure 2-4. Each item is identified by an index number which corresponds to the following description:

① **CLOSED CIRCUIT TV MONITOR** — Operation will be covered in conjunction with figure 2-14.

② **UHF/VHF TELEVISION RECEIVER**

③ **WATER IN FILTER** — Light and buzzer alarm.

④ **ANTENNA** Switches — Both switches must be pushed simultaneously to cause raising or lowering of TV antenna. Indicator will light when TV antenna is up from its secured position when ignition switch is turned on.



- ⑤ **ALTIMETER** — Indicates coach height above sea level. (Zeroing adjustment can be used to calibrate unit at known elevations.)
- ⑥ **ACCESSORY Position** — See item (3), figure 2-2.
- ⑦ **TRIP ODOMETER** — Depress bar to reset.
- ⑧ **SAFELINE ALARM** — The Safeline alarm operates whenever the shoreline is connected to the coach and the ignition switch is in **ON** position as a reminder to disconnect the shoreline before driving away.

With the Safeline switch **ON**, the alarm is given by buzzer sound and red light. The buzzer can be deactivated in favor of a flashing amber light by turning off the switch.

- ⑨ **GENERATOR START/STOP Switch** — Provides local control for generator operation. Press this center-off momentary switch to **START** position and hold until generator starts, as indicated by the switch indicator illuminating. If generator does not start within 2 to 5 seconds, release switch, wait 30 seconds, then try again. To shut down the generator, press to **OFF** position and hold until light extinguishes.

Caution

Do not start the generator when a heavy circuit load is on-line, such as the air conditioners. This can cause an excessive strain on the generator rotating components and may result in equipment damage.

Note

When starting the generator during cold weather, press the switch to STOP position for 15-20 seconds. This activates the glow plugs for easier starting.

- ⑩ **CLOCK PANEL** — As shown in figure 2-5, this panel includes a digital readout. Four switches to the left of the display set clock timing. To set **TIME** display, press **HR SET/MIN SET** switch to **HR SET** position and hold until correct hour is displayed; repeat with switch in **MIN SET** position until correct minutes are displayed.

The **ELAPSED TIME** display will show elapsed time in terms of hours and minutes, or in minutes and seconds, depending on the position of the

HRS/MIN - MIN/SEC SWITCH. Set this switch as desired, press **ZERO** to reset the display to a 00:00 readout, and the elapsed time will count. The **HOLD/GO** switch may be set to **HOLD** position to suspend operation of the elapsed time display; for elapsed time operation, leave switch in **GO** position.

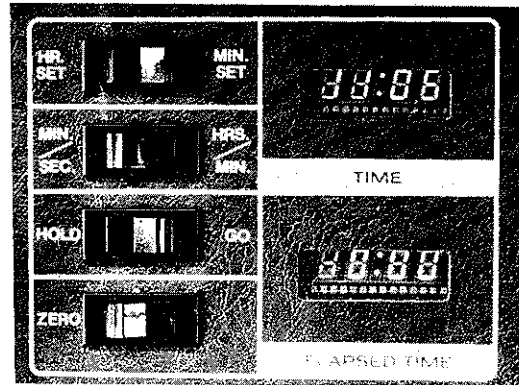

Figure 2-5. Digital Clock/Elapsed Time Display

- ⑪ **AIR CONDITIONER RIGHT FAN Switch** — Three speed blower for right front area of coach.
- ⑫ **AIR CONDITIONER Temperature Selector** — Thermostat setting controls temperature by cycling compressor.
- ⑬ **AIR CONDITIONER LEFT FAN Switch** — Three speed blower for left front area of coach. Left fan switch must be in either **HI**, **MED**, or **LOW** to energize compressor.

Remote Spotlight Controls

The optional roof-mounted remote-control high intensity spotlight is operated by the **SPOTLIGHT** controls located in the overhead dash. The spotlight produces 100,000 BCP (beam candle-power) and can be turned on and off, positioned horizontally or vertically at an adjustable rate of speed, and can be used for spot- or flood-lighting. The following controls operate the spotlight:

- ⑭ **SPOTLIGHT AIM Control** — Controls horizontal and vertical beam position.
- ⑮ **SPOTLIGHT SPEED Control** — Adjusts speed of light head movement.
- ⑯ **SPOTLIGHT BEAM SELECTOR Switch** — Depressing left side of switch activates **FLOOD** while right side pressure selects **SPOT**. Center position is **OFF**.



⑰ **SPOTLIGHT SELECTOR** Switch — Depressing switch, left or right, selects L.H. or R.H. light operation. This switch is functional only when dual spotlights are installed.

⑱ **CAMERA DEFOG** Switch — Energizes fan in compartment for Closed Circuit TV (CCTV) camera.

⑲ **DASH DIMMER** — This control will only operate when the headlight switch is on. The background lighting (electroluminescent) for the upper dash can be brightened by turning counter-clockwise and dimmed by turning clockwise.

⑳ **AUX. PUMP** Switch — Controls the auxiliary water pump (under floor at road side rear) that boosts the circulation of engine coolant through the water heater heat exchanger and chassis heaters in the bedroom, kitchen and living room.

㉑ **HEAT SELECTOR** Switch — Operates solenoid valves in engine coolant line to divert coolant flow through hot water heater and chassis heaters when this switch is in **WINTER** position. Setting the switch to **SUMMER** position causes the coolant to flow through the hot water supply heater coil only.

㉒ **PILOT'S LEFT OVERHEAD CONTROL PANEL** — Functions of this panel will be discussed with figure 2-6.

Pilot's Left Overhead Control Panel Figure 2-6.

① **C.B.** — Jack for headphone listening with volume control.

② **STEREO JACK** — For headphone use with AM/FM Stereo Tuner/Cassette Player.

③ **DIGITELL COMMAND** Station — To discontinue an alarm condition, depress the **COMMAND** switch during the announcement.

④ **EXHAUST FAN** Controls for Living Room — Remote switches for raising or lowering vent lid turning lights and fan off and on.

⑤ **AIR CONDITIONING** Remote Switches — Permit air conditioning control by the pilot. See Section III for full description.

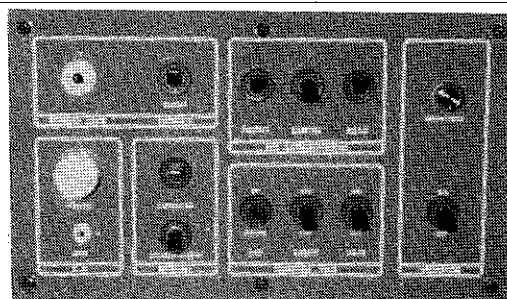

Figure 2-6. Pilot's Left Overhead Control Panel

⑥ **MONITOR** Controls — **CCTV ON/OFF** and **BRIGHTNESS**.

Co-Pilot's Area Overhead Dash Figure 2-7

① **GENERATOR OIL PRESSURE** Gauge — Shows the oil pressure, not amount of oil in the generator engine reservoir. This gauge will normally read between 30 and 60 psi. Low oil pressure indications are often a symptom of possible generator failure. Oil level should be checked on a regular basis. Note that the generator has a low-oil pressure shut-off switch which operates if the generator oil pressure falls below 15 psi.

② **GENERATOR WATER TEMP.** Gauge — Displays generator engine coolant temperatures from 100 to 240 degrees. Normal operating temperatures vary from 175 to 190 degrees. If consistently high temperatures are indicated, shut down the generator, wait for the engine to cool, then check radiator coolant level. Note that the generator has a high-temperature shut-off switch which operates if the generator temperature reaches 225 degrees F.

③ **GENERATOR VOLTS** — Expanded-scale voltmeter, with scale graduations from 10 to 16 volts, shows the condition of the generator battery. Normally, the battery voltage varies from 12 to 13 volts; under starting load it may drop to about 10.5 volts and then rise to about 14.0 when the generator starts and begins charging the battery



through the external isolator unit and battery chargers. Battery voltage readings less than 10.5 or more than 15 are usually a symptom of an electrical system failure or impending battery breakdown.

④ **GENERATOR HOURS RUN** Meter — Indicates total hours of generator operation.

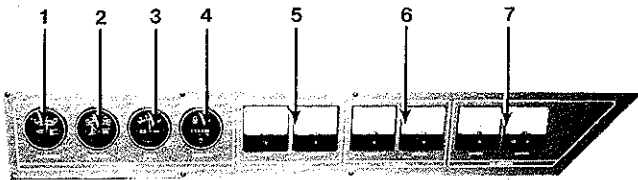

Figure 2-7. Co-Pilot's Area Overhead Dash

⑤ **D.C. AMPERAGE** — Ammeter on left (labelled **CHARGE**) shows net current flow to or from batteries. Needle movement from the center of the gauge indicates discharge to the left and charge to the right. When parked, following highway travel, it is normal to see a needle position to the left of center even when plugged into shore power (or running generator). This will gradually diminish and should eventually show some movement to the right with coach loads turned off.

Ammeter on right (labelled **DISCHARGE**) shows current demand of 12 volt load.

⑥ **A.C. VOLTAGE** — Voltmeter on left monitors LEG ONE while that on right monitors LEG TWO of 120 volt alternating current circuits.

Caution

Appliances can be damaged by low voltage. Loads should be balanced so voltage does not drop below 110 volts for either leg. Low campground (shorepower) voltage can be detected quickly from gauge readings. If cause of low campground voltage can not be corrected, generator power will have to be used during periods of high appliance demands.

⑦ **A.C. AMPERAGE** — Ammeters show current flow in LEG ONE (left) and LEG TWO (right) of 120 volt alternating current circuits.

Leveling Jacks Controls

The motorhome is optionally equipped with four heavy-duty leveling jacks; one at each corner of the chassis. The jacks are the fold-down type, and cannot be extended until they are unfolded.

Overall system operation is monitored at the lower dash, while each jack is independently operated by one of four respective **EXTEND-RETRACT** levers located on the floor to the left of the driver, figure 2-8. Separate dash indicators and a buzzer (when ignition switch is on) provide visual and audible signals to show that the associated leveling jacks are not stowed to a safe travel position.

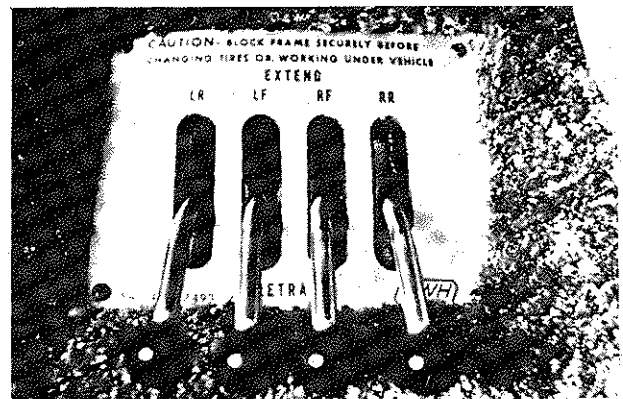

Figure 2-8. Leveling Jack Controls.

Caution

Be sure that the frame is securely blocked before changing tires or working beneath the coach.



Use the following procedures to operate the leveling jacks:

Note

12 Volt master switch must be on to operate leveling jacks.

① Set **LEVEL MASTER** switch (item 36 figure 2-2) to **ON** position. Note that one or more blue **LEVEL SYSTEM** indicators may light. **LEVEL SYSTEM** indicators **LF**, **RF**, **LR** and **RR** are lit only when the respective corner of the coach is low.

② Unfold the leveling jacks by setting the floor controls to **EXTEND** position. As soon as the jacks contact the ground, as indicated by the characteristic landing gear **thump**, release the respective control lever to prevent further jack movement.

Note that the red **LEVEL WARNING SYSTEM** indicators will be lit to show that the jacks are no longer in the stowed (**RETRACT**) position.

③ De-pressurize the air suspension system by setting the **SUSP. DUMP** switch to **DUMP** (down).

Caution

Do not dump the coach air suspension system until the leveling jacks are unstowed and vertical or the coach chassis may be too low to permit the jacks to be unstowed.

④ Operate the **EXTEND-RETRACT** levers for the leveling jacks as necessary to level the coach. The blue and **LEVEL SYSTEM** indicators will extinguish when the respective corners are leveled.

⑤ To restow the leveling jacks prior to moving the coach, start engine to initiate air compressor operation, repressurize the air suspension system by setting the **DUMP** switch to the **FILL** (up) position.

⑥ When the air suspension is once again stabilized, pull all four leveling jacks controls back to the **RETRACT** (locked) position. The red warning indicators will extinguish when the associated jack is in the stowed position; one or more blue indicators may be lit, but may be disregarded at this time.

⑦ Set **LEVEL MASTER** switch to **OFF** position. This completes one full operating cycle for the leveling jacks system.

Note

If the jacks are not withdrawn before driving away, the buzzer will sound.

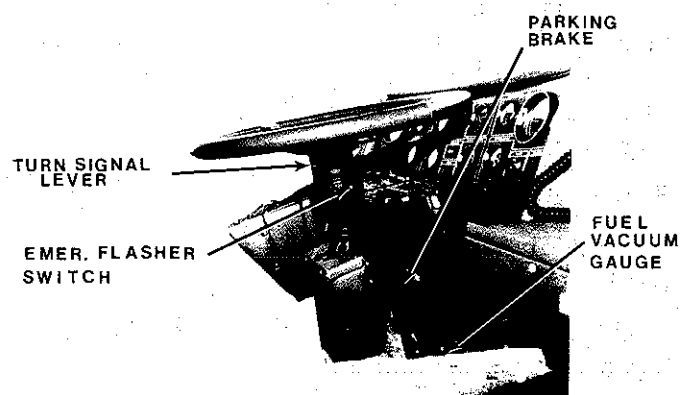

Figure 2-9. Steering Column Area Controls.



Steering Column Area

The steering column area, figure 2-9, includes controls located on the steering column, and under the dash as well as a gauge on the engine cover.

Horn — Operate the horn by pressing in on the center section of the wheel. Select air or electric horn with the **HORN SELECTOR** switch on the dash.

Turn Signal Lever — Move lever forward to signal a right turn; move rearward to signal a left turn.

Emergency Flasher Switch — The emergency flasher switch is located on the right side of the steering column. Push the switch inward to turn on the flashing warning lights; pull switch outward to shut flashers off. Note that the dash directional lights flash in unison.

Fuel Vacuum Gauge — Located in engine cover. Racor fuel filter element should be changed when pointer goes into red!

Parking Brake — The **Parking Brake** control is located under the lower dash, to the right of the steering column. Note that the parking brake cannot be released unless the system air pressure is at least 65 psi.

12 Volt Master Switch — This switch is hidden on an inner dash panel directly in front of (and below) the **Parking Brake** control. Use this switch to shut off 12 volt battery power to all circuits except digital clocks, radio memory, monitoring panel functions, refrigerator control system, and burglar alarm.

Floor Controls

Headlight Dimmer Switch — Close to outside wall.

Air Horn Foot Switch — Operates highway horns. Close to steering column.

Accelerator Pedal — Controls engine fuel flow to select power output. See Diesel Engine/Transmission Operation later in this section for detailed description.

Brake Pedal — The coach is equipped with a dual air brake system which includes independent systems for the front and rear service brakes. A separate reservoir and panel-mounted pressure gauge is provided for each service brake system

(**AIR PRESSURE FRONT** and **AIR PRESSURE REAR**).

Leveling Jack Controls — Described previously with figure 2-8.

Transmission Gear Selector Console Figure 2-10.

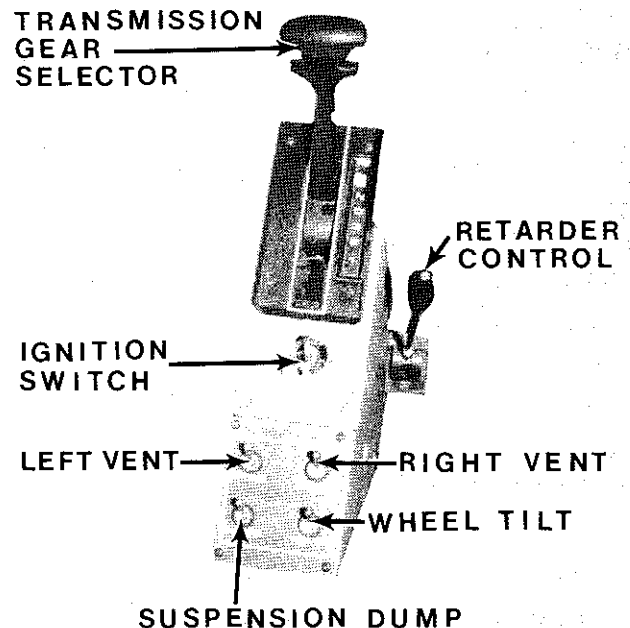

Figure 2-10. Transmission Gear Selector Console.

Transmission Gear Selector — Enables selection of desired 1 through 4 forward speeds or reverse **R**. See Diesel Engine/Transmission Operation later in this section for detailed description.

Ignition Switch — A four-position, standard-type key switch. In **OFF** position (center), ignition and accessory positions are disabled and the key can be inserted or removed. In **ON** position (right) the battery is connected to the engine-run ignition circuits and the key can be advanced to **START** to start the engine, providing that the transmission selector is in neutral **N** position. **ACCESSORY** position (left) allows operation of accessories without activating the engine-run circuits.

RETARDER HAND CONTROL — This five position switch allows full or partial application of the drive line retarder. Operation will be explained later in this section.



LEFT VENT AND RIGHT VENT Switches — Operate the air cylinder controlled air vents to direct fresh air to the pilot and co-pilot areas.

Air Suspension System

Your motorhome is equipped with air suspension bags which **cushion** the front and rear axles. Dumping these air bags when the vehicle is parked allows the rubber bumpers to come together and eliminate vehicle **springiness**. The **SUSP. DUMP** switch controls the dumping and filling of the suspension air bags.

Note

The accessory air tank must contain at least 65 PSI pressure for the air switch to function. The accessory air tank pressure does not register directly on the dash air pressure gauges but when the dash gauges register 65 or above, there is ample pressure.

Moving the **SUSP. DUMP** switch toggle down (to the rear) applies air pressure to three air pilot-operated valves on the suspension system. Two of these valves are located on the rear axle; and one is located on the front axle. The pilot air shifts the valves, cutting off the air supply to the air bags and allows the air in the bags to escape. After the suspension system has been dumped, and the ignition is turned on, a warning pilot light is illuminated on the dash to warn the driver that the system is dumped and not to drive the vehicle until the air switch toggle is set to the up position.

Note

If the leveling jacks are to be used while the coach is parked, the jacks must be lowered to level the vehicle before the air bags are dumped. If the air bags are dumped before the jacks are down, the vehicle is too low for the jacks to unfold into lifting position properly. This could damage the jacks.

SUSP. DUMP Switch — This switch controls the inflation of the air suspension system. Move toggle down (to the rear) to dump the bags. Note that **SUSP. DUMP ACCESSORY WARNING** light is lit; set switch to **up** position to re-inflate the air bags before driving away. (System air pressure must be at least 65 psi.)

WHEEL TILT Switch — Move toggle down to release steering column so wheel may be moved to desired position. Move lever up to lock.

Caution

Always make sure that lever is in the fully locked position in whichever detent setting is used. Do not change the wheel tilt setting while the coach is in motion.

Radar Detector

A high-sensitivity superheterodyne microwave radar detector is installed as standard equipment on your coach. This unit, shown in figure 2-11, is designed to activate when transmissions are received from radar-type speed detection equipment.

Note

Because some states have ruled radar detection equipment illegal, it is the responsibility of the driver or owner to obey the appropriate laws. (There are quick-disconnect features provided which allow for easy removal of the unit.)

CONTROLS AND INDICATORS — Operating controls and indicators are listed below:

VOLUME ON-OFF CONTROL — Adjusts volume of beeper alarm and controls **ON-OFF** operation.

POWER Indicator — Red LED that lights when power is on.

SIGNAL STRENGTH METER — Displays signal strength of the detected radar signals. Operates in conjunction with the 1,000-cycle beep tones from the built-in speaker so that high readings and rapid beeping indicate a radar in close proximity; while low signal strength readings and spaced beeps indicate the reverse. Learn to interpret the readings correctly. (Note that lowering the beep volume level will not affect the operation of the signal strength meter.)

CITY-HIGHWAY CONTROL — Set to **HIGHWAY** position for maximum sensitivity on both **X**- and **K**-bands. Set to **CITY** position for reduced sensitivity on **X**-band (usually used for highway and rural applications, but also commonly encoun-



tered in city driving by unit sensing **stray** radar transmissions) and continued high sensitivity on **K-band** (urban-type radars).

ALERT Indicator and Dimmer — In addition to its radar-detecting capability, the unit also includes a photoelectric ambient-light monitor to control the illumination intensity of the radar-warning **ALERT** indicator in proportion to coach interior lighting conditions.

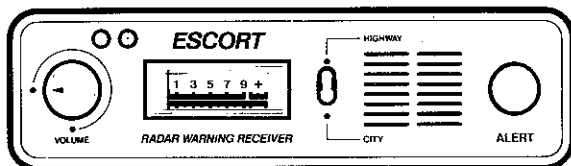

Figure 2-11. Radar Detector.

Note

The radar detector is designed to be removed and disconnected quickly and easily. Note that the electrical quick-disconnect connector also includes a low-amperage power line fuse to protect the unit. In the event that the unit is completely inoperative, check for a defective line fuse by disassembling the connector and replacing the fuse.

Radar Operation

Although the detector is designed to prevent reception of false alarms, microwave tele-communications towers can sometimes cause a false alarm. The extreme sensitivity of the unit makes it most important for the driver to heed **all** warnings. Reflected radar scatter from a moving radar, going in the same direction ahead of you, or behind you, can be detected by your unit at a greater range than the effective distance of police radar!

Operate the radar detector as follows:

1. Turn on radar detector by turning the **VOLUME** control clockwise. A four-second tone will sound so that volume can be set and the operation of the **ALERT** indicator and signal strength meter can be checked. **ALERT** blinks in conjunction with the beep sounds; meter displays average signal strength.
2. Set **CITY-HIGHWAY** switch to appropriate position and unit is ready for operation.

Note

The intensity of the **ALERT** lamp will vary in accordance with the ambient coach interior lighting level, as monitored by the photoelectric detector on the unit. Bright coach interior increases **ALERT** lamp intensity; dim interior lighting results in lowered lamp intensity.

Interpreting Radar Alerts

When a radar is detected, the **ALERT** indicator flashes and a beep tone is heard. The rate at which these indications are given are a measure of the proximity of the radar to the detector: the closer the radar, the faster the beeping/flashing rate; the more distant the sound also indicates which type of radar is being picked up by the detector.

X-band radars will cause the unit to emit single beeps; while **K-band** radar transmissions will be identified by rapid dual beeps. The meter also indicates the proximity of the radar transmitter in terms of signal strength on a 1 to 9 scale. Generally, the detector will not sound the alarm alert until the signal strength is greater than a 5 reading on the meter. However, all indications should be heeded.

Use the **CITY-HIGHWAY** switch in **CITY** position to reduce the sensitivity of the detector when traveling in densely-populated areas to diminish detector responses to other types of microwave sources such as door openers, burglar alarms, etc. Leave this switch in **HIGHWAY** position for maximum sensitivity for most driving situations.

Seat Controls

Electrically and air-operated six-way seat adjustments are built into the pilot's and co-pilot's seats. A typical control panel is shown in figure 2-12.

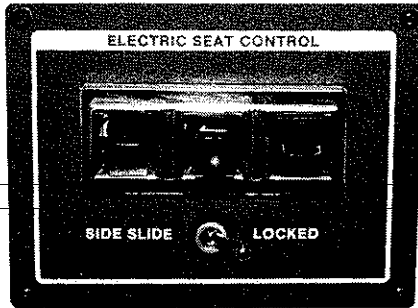

Figure 2-12. Seat Controls

Three electric **SEAT CONTROLS** are used to control seat bench tilt, up-down and front-back seat movement, and seat back tilt. The **SIDE SLIDE** switch operates an air cylinder which locks the position of the slide mechanism beneath the seat. Set switch to **SIDE SLIDE** to disengage the seat slide lock, adjust side-to-side position, then set to **LOCKED** to re-engage lock mechanism. This switch must be kept **LOCKED** to secure the seat during travel.

These seats may be rotated by releasing the lever underneath the seat base on the right side.

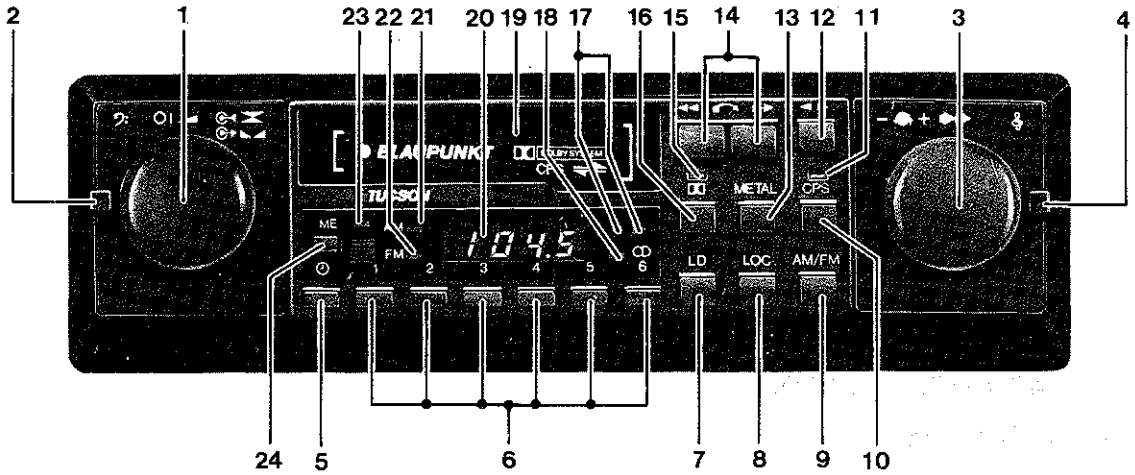

Figure 2-13. AM/FM Stereo Tuner/Cassette Player.

**AM/FM Stereo
Tuner/Cassette Player
Operating Controls
Figure 2-13**

- ① On/Off, volume (turn), balance (pull & turn), fader (push & turn)
- ② Bass
- ③ Manual Tuning momentary or hold (turn), signal seeking (push in)
- ④ Treble
- ⑤ Clock on and reset
- ⑥ 6 electronic station-presets on each band (1AM and 1 FM on each preset)
- ⑦ Loudness
- ⑧ Local/distant
- ⑨ AM/FM selector
- ⑩ Cassette program selector on/off
- ⑪ CPS light
- ⑫ Cassette side change
- ⑬ Metal tape
- ⑭ Fast forward (FF) rewind (REW) cassette eject (push both buttons)
- ⑮ Dolby light
- ⑯ Dolby on/off
- ⑰ Tape travel lights
- ⑱ FM Stereo light

- ⑲ Cassette slot
- ⑳ Digital frequency/clock display
- ㉑ AM light
- ㉒ FM light
- ㉓ Memory entry, light
- ㉔ Memory entry, station preset or clock reset

Cassette Deck Operation

Caution

The Tucson is designed for high quality C30, C45, C60 and C90 cassette tapes. Use only such high quality tapes. Inferior quality tapes or cassette housings can seriously damage the precision tape decks. **Do not use bargain, non-brand name tapes. Do not use C120 tapes.**

Cassette Handling

Before inserting a cassette into the tape deck slot, make sure there is no excess slack (several loose turns) in the tape reels. Insert a pencil in the loose reel hub and turn it until snug while holding the other hub.

Store cassettes in their plastic boxes. They have retainers which prevent tape unwinding through handling or movement and protect the tape from moisture, dust and direct sunlight.

Do **not** leave cassettes on such exposed areas as the dash or rear deck.



Do **not** otherwise expose cassettes to extreme heat (over 122°F or 50°C) or direct sunlight. They will cause warpage that can seriously affect the sound quality.

Do **not** leave any cassettes in the vehicle in cold weather (14°F or -10°C).

Use cassettes and the tape deck only after the vehicle has been warmed to between 64° and 68°F (18° to 20°C) or normal room temperature.

Do **not** use a screw driver or other metal object near the tape head.

Clean all tape contact surfaces periodically with a soft lint-free cloth and a head cleaner solvent to remove dust or accumulated oxide.

1. **To Start a Cassette** — Turn left inner **ON/OFF** knob to right (clockwise) to turn power **ON** in radio mode.

Insert cassette, with tape opening on right, and desired side up, into the **BLAUPUNKT**-label slot (19). It will open inward and receive the cassette until it seats inside. The radio mode will then shut off automatically and the cassette will start.

One of the two arrows, (17) (top right on glass dial) will light up to show direction of tape travel. The direction depends on the side that is being played.

2. **To Control Volume** — The same **ON/OFF** knob (1) (step 1) will increase the volume as you turn it clockwise, decrease it as you turn left (counter-clockwise).

3. **To Balance Stereo** — pull the same **ON/OFF** knob (1) **outward** and while holding outward pressure, turn it right or left for the desired balance. A click at the mid-point position indicates equal balance of right and left channels.

4. **To Control Fader (Front and Rear Speaker Volume)** — Press same **ON/OFF** knob (1) **inward** and while holding it in, turn it left or right for the desired speaker balance. The click position provides equal balance of front and rear speakers.

5. **For Bass and Treble Tone Control** — To control the bass, turn **outer** knob (2) on same **ON/OFF** knob shaft, to right or left for desired bass sound.

To control the treble, turn **outer** knob (4) on **right** shaft to the right or left for the desired treble sound. Both knobs have mid-point click positions where sound is equally bass and treble; knob handles will be horizontal.

6. **Automatic and Manual Reverse** — When one side of the cassette is completed, the auto-reverse starts the second side automatically. If the tape is left on, it will continue to change sides as each side is completed, until shut off or ejected.

To change sides manually, press button (12) (See Figure 1).

The tape-travel light (17) will indicate the direction of travel. There is no need to eject the cassette to play the reverse side.

7. **Fast Forward or Rewind** — To **advance** the tape rapidly, press one of the two top protruding buttons (14) that **corresponds** to the direction indicated by the lit tape-travel arrow (17) it will lock, until released by lightly pressing the button still protruding. Both will pop out.

To **rewind** the tape, press one of the same two buttons that is **opposite** to the travel light arrow. Release with the other button.

8. **To Eject the Cassette** — Press both buttons (14). Radio mode will resume.

9. **To Play Dolby Cassettes** — Press the Dolby button (16). Play non-Dolby cassettes with button (16) **out**. Press to release button.

10. **To Play Metal or Chrome Dioxide Tapes** — Press the Metal button (13). In the **IN** position, this **tape equalization** switch selects playback equalization of 70 us. The **out** position is 120 us. Press to release.

11. **Loudness Switch** — To overcome the acoustic character of human ears which do not hear low or high notes when the volume is low, press the LD button (7). It boosts the low and high sound frequencies to compensate, producing a rich sound quality at low volume. Press to release.

12. **Cassette Program Selection (CPS)** — Press the CPS button (10) and then the FF or RW button to get to the start of the next or previous musical division (symphony movement



or program piece) CPS automatically seeks a pause of more than 3 seconds. The CPS indicator (11) above the button will light. After pressing the CPS button:

To play the next piece — press one of the two FF/RW buttons (14) (see paragraph 7) that corresponds to the lit tape direction arrow (17) (paragraph 1). The tape will advance rapidly as the applicable direction arrow blinks, until the start is located and the next piece plays.

The CPS pause-searching mechanism must traverse a tape length equivalent to at least 8 seconds worth of playing time, before stopping at a pause. In other words, if actuated at a point **less** than 8 seconds before the next pause, it will skip that pause and continue to wind up, through the next piece, stopping only at the pause that follows the latter.

The **8-second minimum** holds, regardless of the direction of tape travel (FF or RW). Thus, you can only use CPS (10) to replay a specific piece you are playing. If you are at least 8 seconds into that piece (or, by the same token, **less** than 8 seconds into the **next** piece).

Examples — If **B** is playing, the next piece **C** will be located if the search started: more than 8 seconds before the end of the piece **B** that is playing; or within 8 seconds before the end of the piece **A** that preceded it; or during the pause between **A** and **B**.

To replay A, the completed piece — or the one that is playing, press the appropriate button (14) opposite to the direction arrow (17) that is lit. The tape will rewind as the direction arrow blinks, until it locates the start, and the A piece will replay. You can make that replay choice for **A** any time between a point 8 seconds after **A** started until 8 seconds after the next (**B**) piece starts.

If you want to leap-frog past more than one piece, leave the **CPS** button **in**. Then press the appropriate button (14) and press each time it starts a new piece until (winding forward or backward) you reach the piece you want. To return to normal play, press the **CPS** button (10); it will pop out.

Note

Because CPS searches for a 3-second or longer pause in the program it may restart at such undesirable places as a pause in conversation or song, or a low-level point in music of comparatively higher sound levels. CPS may also skip over pauses of less than 3 seconds duration, or those with excessive background hum or noise.

Radio Operation

- 1. Power and Sound Controls** — These controls, shown in figure 2-13 and described in the Cassette Deck section, are used in the radio mode as well. (See preceding section on Controls, paragraphs 2 through 5, for power **ON/OFF**, volume balance, fader, bass and treble controls, and paragraph 11 for the loudness LD control. The FM/Stereo light (18) will go **ON** when stereo radio is **ON**.)
- 2. To Select waveband** — Press **IN** the AM/FM button (9) to get FM, and press to release for AM (button **out**). The appropriate AM or FM light (21 or 22) on the left side of the glass dial will indicate the selected waveband.
- 3. To Tune in a Station: 3 Methods**
 - I. Manually** — **Turn** the tuning knob (3) to left or right and **release**, to change frequency by steps. To scan frequencies, **turn** the knob to left or right and **hold**. It starts slowly, then increases speed of scan. In either method, the clock dial will indicate the frequency.

The frequency ranges are:

AM: 530 KHz to 1620 KHz in 10 KHz intervals

FM: 87.9 MHz to 107.9 MHz in 0.2 MHz intervals

- II. Automatic Station Seeking** — **Push in** the same knob and release. The automatic seeking scanner, a built-in microprocessor, will find and lock in on the nearest station. Press again to get the next station and repeat as necessary. If the knob is pushed in **while** the scanner is seeking the station, it will stop seeking.

To prevent error in station-seeking caused by the influence of a very strong station, keep the local/distant button, **LOC** (8), pushed **in** in



the local position (refer to paragraph 6). It reduces overloading.

III. Station Memory Storage(6 Numbered Buttons.) — For pushbutton tuning of frequently used stations (one AM and one FM for each button):

(a) Tune in desired station as described above, manually or automatically.

(b) Press and release the memory entry. **ME** button (24) (left side). The adjacent **ME** light (23) indicates you have 5 seconds to press one of the six numbered preset buttons below the dial; after 5 seconds the light goes off.

(c) Press the numbered button before the light goes off and your station is preset. (The light will go off when you press the button).

(d) Similarly, press **ME** plus another numbered button, for each station you tune in for memory storage on the same waveband (AM or FM).

(e) Press the FM button (9) to change the waveband. Again, tune-in in turn each desired station on the other waveband, and press the **ME** plus one of the numbered preset buttons, to enter the station in memory for pushbutton tuning. As stated, each button holds one AM and one FM station.

(f) When you select a station by pushing its numbered preset button, its frequency is shown on the clock dial.

(g) To change a preset station to another, just tune in the newly-selected station and enter it as described above.

(h) If you press the **ME** button and do not press any preset button before the **ME** light goes off in 5 seconds, the station will not be preset. Try again.

(i) Memory is not erased when power is **OFF** because of the direct connection to the battery.

4. Frequency and Clock Display — The digital display in the center of the glass dial indicates KHz frequencies on AM, or MHz on FM, when unit power is **ON**. To get the hours and minutes display, press the clock button (5) on the left bottom of the dial.

5. To Reset Digital Clock —

(a) With ignition and power **ON**, press the clock button (5) to get the time display.

(b) To correct the **HOUR**, press the **ME** button (24) on the left of the glass dial, and press in and turn the tuning knob (on the right) **counter-clockwise** (3). Release the knob when the display has advanced to the correct **HOUR**.

(c) To correct the **MINUTES**, press the **ME** button, and press in and turn the tuning knob **clockwise**. Release the knob when the display has advanced to the correct **MINUTE**.

6. Local/Distant Switch — When the **LOC** button (8) is pressed **IN** for AM or FM reception, the radio receives only local, strong stations. Press again for the **out** position to tune in all stations including weak and distant signals. The automatic signal-seeking (previous paragraph 3) will lock in on a strong station in **LOC** position **IN**.

7. Dolby Broadcasts — To get best reception from FM stations that broadcast in Dolby, press the Dolby button (16) (the light (15) will go on). It excludes more background noise and improves dynamic frequency range.

8. ARI (Automatic Radio Information) — This system permits reception of current traffic information in several operating modes. Although only recently introduced to North America, it has been in wide use in Western Europe. The TUCSON has a built-in connection for addition of an ARI adapter unit to receive the ARI traffic reports when broadcasts are started in your area. The media and advertisements will publicly announce the implementation of this ARI system. Within the next several years, ARI will help improve traffic flow and reduce jams during rush hours in many urban centers in North America.

Closed Circuit TV Monitor System

System Components

Besides the TV receiver on the upper panel, the CCTV Monitor receiver system also includes:

- CCTV camera, located in the rear of the coach, figure 2-14.
- Picture brightness and ON/OFF switch on pilot's left overhead control panel, figure 2-6.

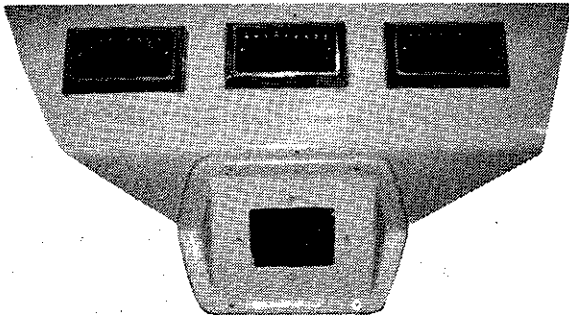

Figure 2-14. CCTV Camera Port

CCTV Operation

The rear-facing CCTV camera transmits images directly to the monitor via coach cabling.

Note that the system requires a brief warmup period before achieving full resolution. CCTV camera controls are preset and the standard lens supplied with the unit is designed to focus from about two feet to infinity.

TV Operation

The UHF/VHF television receiver, figure 2-4, item 2, is a standard TV. Operation is covered in the owner's manual supplied with the set.

TV Antenna and Rotator System

The control components of the antenna and rotator are a hand-held switch-operated rotator, radome-type TV roof antenna, coupler-switcher for the antenna or cable inputs and a switch for raising and lowering the antenna.

The **A-C** switch on the coupler antenna **A** or cable **C** input via connections in shoreline compartment at the rear of the coach. Additional switches on the coupler route the antenna/cable inputs to the TV receiver.

The antenna rotator controls the position of the TV antenna within the radome. The three-position momentary switch (center **OFF**) provides right/left antenna rotation, with antenna position displayed on the control unit. The rotator power supply is also located in the radome, which, in addition to the antenna, also includes an amplifier and rotator mechanism. The remote power supply is designed to operate from either 120 volts ac or 12 volts dc.

Low-loss coaxial cable and three-wire rotator control cable interconnect the antenna and power supply.



Figure 2-15. Extendable TV Antenna Radome

Note that a .8 ampere fuse is connected in the 12-volt dc supply line to the unit. In the event that the TV set exhibits problems relating to low antenna input (**ghosts, etc.**) check this fuse before servicing the TV set.

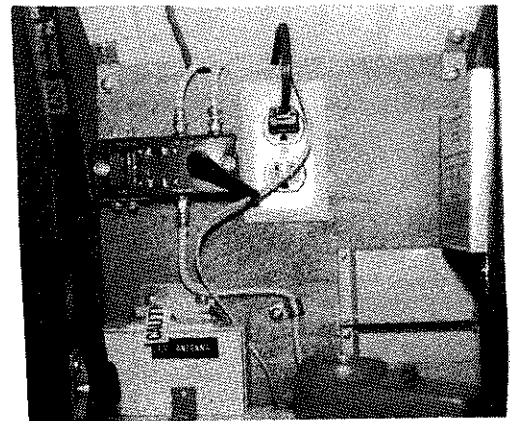

Figure 2-16. Antenna Control Panel

Antenna Operation

With the TV on and a station tuned in, rotate the antenna by pressing the rocker switch located on the control unit. Press the right side of the switch to turn the antenna clockwise; press the left side to turn the antenna counter-clockwise. Although the actual antenna movement is not visible, the indicator arrow on the control unit lights and shows the direction of the antenna. When the antenna has made one full turn (360 degrees), the End of



Rotation light comes on. Observe the picture while rotating the antenna, first in one direction, then the other, to obtain best picture quality.

The switches for raising or lowering the antenna are located in the Pilot's Area Overhead Dash and Radio Panel, figure 2-4, item 4.

CB Transceiver Unit

The CB transceiver has all the functions in the mike, figure 2-17, while the electronic parts are in the **black box** module mounted in the dash area.

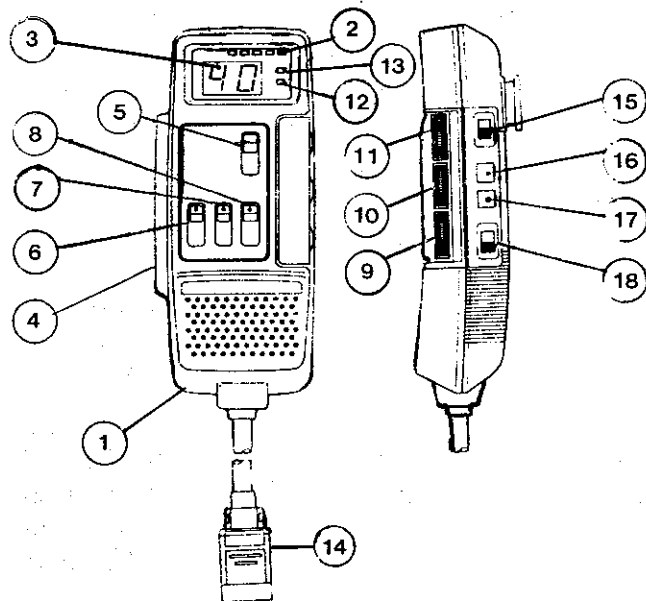

Figure 2-17. CB Transceiver Unit

Controls and Indicators

The functions of the controls and indicators shown in figure 2-17 are described in the following paragraphs:

- ① **MICROPHONE** —
- ② **LED S/MOD LEVEL INDICATOR** — The microphone is equipped with a combination S/MOD LEVEL INDICATOR. In the receive mode, some or all of the LED's will light up indicating the strength of the incoming signals by the number of LEDs. In the transmit mode, it indicates the relative modulation level.
- ③ **CB CHANNEL DISPLAY** — The selected channel is shown by the LED digital read-out CB CHANNEL DISPLAY on the microphone.

④ **PUSH TO TALK (PTT) SWITCH** — The CB transceiver and receiver are controlled by this PTT switch. Press this switch to activate the transmitter. Release this switch to receive CB signals.

⑤ **EMERGENCY CHANNEL (CH.9) SWITCH** — You can transmit or receive at the emergency channel (CH.9) at any time by setting this switch.

⑥ **PA SWITCH** — The unit is converted to a public address system when the PA switch is set to the PA position and a PA speaker is plugged into the PA JACK. In the PA mode, the CB channel display reads PA.

⑦ **NB (NOISE BLANKER)/ANL (AUTOMATIC NOISE LIMITER) SWITCH** — Set this switch to the NB/ANL position to reduce noise caused by electric motors, ignition, lighting, etc., normally, leave the switch in the OFF position.

⑧ **AUTO/MANUAL SCAN SELECT SWITCH** —
AUTO position — The channels are scanned until a channel being used (busy) is obtained, with the flick of a finger onto the UP SCAN button (16).
MANUAL position — You can select your desired channel by pressing UP (16) or DOWN (17) SCAN button manually.

⑨ **RF GAIN CONTROL** — In the receive mode, RF gain can be reduced by this control. It is recommendable to adjust this control when incoming signals are too strong and distorted. Usually, set this control to the maximum RF gain (fully CW position).

⑩ **SQUELCH CONTROL** — This control silences the CB receiving noise when signals are not being received. It functions only in the receive mode and does not affect the CB receiver volume during signal reception.

⑪ **VOLUME CONTROL** — Adjust the receiver's sound level by this control.

⑫ **RX INDICATOR** — Lights up in green when the unit is in the receive mode.

⑬ **TX INDICATOR** — Lights up in red when the unit is in the transmit mode.

⑭ **MICROPHONE PLUG** — This plug is to be connected to the microphone receptacle.

⑮ **POWER ON-OFF SWITCH** — To provide power to the module unit, it is necessary to move this switch upward (ON position).



Note

The scanning circuit of the unit is designed to continue to memorize a previously used CB channel, even though you turned off the ON-OFF switch on the microphone.

⑩ UP SCAN BUTTON

⑪ DOWN SCAN BUTTON

⑫ SCAN LOCK SWITCH — CB channels will be changed either up or down by continuing to press (more than 1 second) the UP or DOWN button. In addition, channels can be selected **channel by channel** by pressing the UP or DOWN button at brief intervals.

It is recommended that the SCAN LOCK SWITCH be set after selecting the desired channel in order to avoid the channel change by mis-pressing the UP or DOWN button.

Note

In the transmit mode, the channel is automatically fixed and will not be changed irrespective of the SCAN LOCK switch.

CB Operation

Caution

Never use CB without Antenna.

1. Set the **SQUELCH** control to the minimum squelch position. (Turn the knob fully C.C.W.)
2. Turn the **RF GAIN** control to the maximum (fully C.W.).
3. Turn the **VOLUME** control to the desired level.
4. Select the desired channel by pressing **UP** or **DOWN** button. If you desire, you may lock the channel by setting the **SCAN LOCK** switch.
5. Adjust the **SQUELCH** controls as follows. When no signal is present (noise only), turn the **SQUELCH** control **C.W.** until the CB receiver is silenced. Incoming CB signals will automatically release the squelch enabling you to receive normally. Careful adjustment is necessary because setting too far C.W. will not allow weaker signals to be received through the squelch. S/MOD LEVEL INDICATOR reads the strength of the incoming signals.

6. To transmit, press the **PTT** switch on the microphone. The **TX INDICATOR** comes on and **S/MOD LEVEL INDICATOR** will be flashing when you speak into the microphone. Hold the microphone 1-2 inches away from your mouth and speak in a normal voice. Release the **PTT** switch to receive CB signals.

Note

It may be beneficial to turn the radio/player off when transmitting to avoid the possibility of acoustical feed back.

AUTO/MANUAL SCAN SELECT SWITCH — You have two methods of selecting the channel. One is by Manual Scan and the other is by Auto Scan.

MANUAL SCAN — Set the switch to Manual Position. Then press the UP or DOWN button as desired. If you continue to press the UP or DOWN button more than one second, the channel will be changed upward or downward at high speed. If you press the UP or DOWN button at brief intervals, selection will be **channel by channel**.

AUTO SCAN — Set the switch to AUTO position, and press the UP button. Scanning begins and stops at the first busy (used channel). If the squelch control is set to minimum (C.C.W.) or near the minimum position, the receiver reacts as if all channels are busy. If the squelch control is set to the maximum (C.W.) or near the maximum position, the receiver reacts as if all channels are vacant. In this case, cycling of channel numbers will continue until you set the switch to the **MANUAL SCAN** mode.

Note

Be sure that setting of the **RF GAIN CONTROL** affects the squelch level.

How to Use the Emergency Channel Switch

This switch selects Channel (27.065 MHz) with a top priority to the other function (except PA switch).

Set this switch to CH9 position to receive or transmit the emergency call. Channel 9 has been set aside for emergency communications involving the immediate safety of people or property, or for communications necessary to render assistance to a motorist. When this switch is released,



the channel reverts back to the original channel.

Note

On the air operating technique and allowable communications are prescribed in the FCC rules. We strongly recommend that you do not unknowingly violate these rules.

The scanning circuit is designed to continue to memorize a previously used CB channel number, even though you turn the ignition switch off.

Digitell Monitor

Although the Digitell Monitor is part of the Systems Monitor Panel located on the dinette wall, several of its warning functions are related to features which concern the driving of the motorhome. This unit provides speech-synthesized warnings of the following driving alarm conditions:

- Low on fuel
- Water in fuel

Alarm announcements for these conditions will be repeated every 45 seconds, providing that the alarm condition exists for at least 30 seconds.

Refer to Section 3 for additional information on Digitell operation.

Diesel Engine/Transmission Operation

Proper operation and maintenance are key factors in determining the useful life and operating economy of a diesel engine. Follow these directions for trouble-free, economical operation.

To Start Engine

Caterpillar 3208 Engines will start at temperatures above 10 degrees F (-12 degrees C) without using a starting aid. However, for colder temperatures it may be necessary to activate the engine block heater (120 volt ac-operated). The **ENGINE BLOCK HEATER** switch is located in the toe board in front of the co-pilot seat. Remember to turn switch **OFF** after starting.

1. Place transmission in **NEUTRAL**.
2. Turn ignition switch to **START**. Engine should start within 5 seconds. If engine fails to start within 30 seconds, release the starter switch and wait two minutes to allow the starter motor to cool before trying again.

3. As soon as the engine starts, reduce engine speed to low idle. After normal oil pressure is indicated, speed may be increased to build up air pressure more rapidly.

4. Do not apply a load to the engine or increase engine speed until oil pressure gauge indicates normal.

5. Operate the engine at low load and low rpm until the temperature gauge starts to move. Check all gauges during warmup period.

To Stop Engine

Caution

Before stopping the engine, operate at low idle for a minute or so. This will allow hot areas in the engine to cool gradually and extend engine life.

With the vehicle stopped, apply the parking brake and place the transmission shift lever in **NEUTRAL**. Turn the ignition switch to the **OFF** position. This shuts off the fuel supply to the engine.

Using the Jacobs Drive Line Retarder

Your motorhome is equipped with a Jacobs drive line retarder system which provides electrical braking action. The system is electrically controlled by operation of the lever on the retarder hand control located on the Transmission Gear Selector Console, figure 2-10.

Turn on **RETARDER** Switch. (item 54, figure 2-2) and select desired amount of braking action by moving lever from **OFF** to positions 1-4 for progressively increasing braking action. Any selected setting is on full time. When acceleration is desired move lever to **OFF**.

Trailer Hitch

Hitch capacity is 7,500 pounds tow and 750 pounds tongue weight.

Note

Trailer hitch ball capacity is 6,000 pounds, torque nut to 200 ft.-lb.

Towing

Two towing eyes are provided behind the front bumper.



Caution

Do not tow a vehicle equipped with Allison automatic transmission unless the drive shaft has been removed, or the rear wheels raised from the ground. Do not attempt to tow unit by front axle or cross-member. Damage to wiring and/or air lines can result because of proximity of these items to front cross-member. Do not tow by the bumpers.

Transmission Operation

The Detroit Diesel Allison transmission provides four forward ranges and one in reverse. Speed selection is provided through the transmission shift lever located on the side wall.

The selector lever must be in **N** (neutral) position when the engine is started. If the engine can start in any other position, the neutral start switch deficiency should be corrected as soon as possible. Use **D** position for all normal driving conditions so that the coach begins moving in first gear and upshifts automatically into 2nd, 3rd, and 4th gears. As the coach slows, the transmission automatically downshifts to the correct gear. Use a low gear **2** or **3** when road, load or traffic conditions make it desirable to restrict automatic shifting to a lower range; or use the Jacobs brake drive line retarder, as previously described. Use **1** or **2** when pulling through mud and snow or driving up steep grades. The vehicle should be completely stopped before shifting into reverse.

Driving Tips

Accelerator Control

Foot pressure on the accelerator pedal influences the automatic upshifting or downshifting within each driving range. When the pedal is fully depressed against the floor pedal stop, the transmission automatically upshifts near the recommended governed speed of the engine. A partially-depressed position of the pedal causes the upshifts to occur sooner at a lower engine speed. Shift timing is accomplished by using a cam and cable from the throttle. This throttle-modulation method provides the accurate shift spacing and control necessary for maximum performance.

Downshift Control

The transmission can be downshifted or upshifted, even at full throttle, and, although there is no speed limitation on upshifting, there is a limitation on downshifting and reverse. Good driving practices indicate that downshifting should be avoided when the vehicle is over the maximum speed attainable in the next lower gear. Allison transmission incorporates downshift inhibitors within the valve body to prevent harmful shifts when the vehicle is traveling too fast for the next lower gear. If downshifts are attempted at excessive speeds, the inhibitors prevent the selected downshift until the vehicle reaches an acceptable speed.

Transmission Oil Temperature

Extended operation at low vehicle speeds, with the engine at full throttle, can cause excessively high temperature in the transmission. These temperatures may tend to overheat the engine cooling system as well as cause possible damage to the transmission. If excessive temperature is indicated by the engine coolant temperature gauge, stop the vehicle and determine the cause. If the cooling system appears to be functioning properly, the transmission is probably overheated. Shift to **N** and accelerate the engine to 1,200 to 1,500 RPM. This should reduce the oil sump temperature to operating level within a short time. If high temperatures persist, stop the engine and have the overheating condition investigated by service personnel.

Caution

Do not operate the engine for more than 30 seconds at full throttle with the transmission in gear and the unit stationary. Prolonged operation of this type will cause the transmission oil temperature to become excessively high and may result in severe overheating damage to transmission components.

If the transmission overheats during normal operation, check transmission oil level.



**General Information —
Caterpillar 3208 Engines**

a water sensor, which lights a dash indicator when the water level in the filter bowl is high enough to require drainage.

Caution

Cooling fan operation is controlled electrically by a thermostat which senses engine coolant temperature. Any time the engine is running the fan may engage and start to run without warning. The engine must be shut off and the fan stopped before servicing.

Check crankcase oil level before starting and when refueling. Always check oil level with engine stopped. The dipstick has 2 markings, **FULL** and **ADD**. Maintain oil level between these marks. Do not overfill. Refer to table 8-2 for recommended oil.

- Check (with engine stopped) drive belts for cracks, breaks and frayed edges. While checking belts, look for oil, water or fuel leaks.
- Check (with engine stopped) for water in the fuel. Drain a cupful of fuel from the bottom of the tank to remove water or sediment. Fill fuel tanks after completing a run. Partially-filled tanks will collect moisture if the coach is allowed to sit for an appreciable length of time. Use number 2-D diesel fuel (with a minimum Cetane number of 40). Keep fuel clean. Inspect Racor filter bowl periodically and observe **WATER-IN-FUEL** indications on the dash gauge. Remove and clean filter bowl as necessary.

Number 1-D diesel fuel may be used in cold temperatures or when operating in altitudes above 5,000 feet.

- Check coolant level (with engine cool and off). Fill to the proper level with water and permanent-type anti-freeze, adding one quart of Nalcool 2000 cooling System Conditioner with replenisher coolant. Use clean water that is low in scale-forming minerals, not softened water. Leave space for expansion. (Note that Nalcool 2000 is compatible only with ethylene-glycol base coolants.)

Racor Fuel Filter

A Racor fuel filter/preheater is incorporated in the diesel fuel supply line and processes the fuel supply for maximum purity.

The fuel filter also includes a built-in preheater, which operates from the 12-volt battery supply and



Faint, illegible text at the top left of the page.

First block of faint, illegible text in the upper right section.

Second block of faint, illegible text in the upper right section.

Third block of faint, illegible text in the upper right section.

Fourth block of faint, illegible text in the upper right section.

Fifth block of faint, illegible text in the upper right section.

Sixth block of faint, illegible text in the upper right section.





Section III

Living Area Facilities

This section provides information on operation of the appliances and systems which contribute to comfortable living within your motorhome.

Sofa

Your **Wanderlodge®** sofa converts into a double bed sleeper. To convert the sofa you must first release 2 latches under the front edge of the sofa seat. Then pull out on the seat until the sofa is fully extended and the back of the sofa is lying in the flat position. To fold the sofa back up into the sitting position pull up on the sofa back with the pull strap provided and at the same time push in on the sofa seat with your knees until the sofa latches **click** into the locked position.

Vacuum Cleaner

The vacuum cleaner system, located in the closet in front of the stepwell, figure 3-1, is completely self-contained and supplied with a long flexible hose and wand, carpet, upholstery and crevice tools.

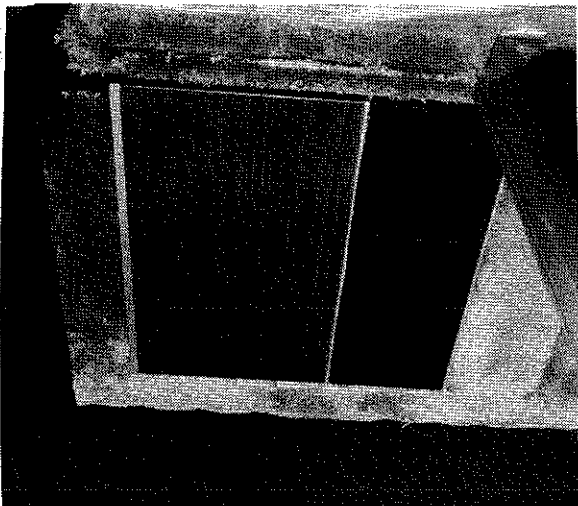

Figure 3-1. Vacuum Cleaner System

Install the flexible hose end-fitting into the corresponding intake hole, accessible when the spring-loaded door is swung aside. The disposable paper bag, located in the compartment to the right of the intake, is easily removed and replaced

when the compartment door is opened (vacuum cleaner should be off when changing bags). A new bag is installed by sliding the cardboard ring on the bag over the intake tube. Clean or replace foam filter periodically to keep system operating efficiently. A power **on-off** switch is located near the closet door opening. Set this switch to **on** and the vacuum will operate whenever the hose is inserted.

Dinette Area

The dinette area, figure 3-2 includes the area thermostat and door chime.

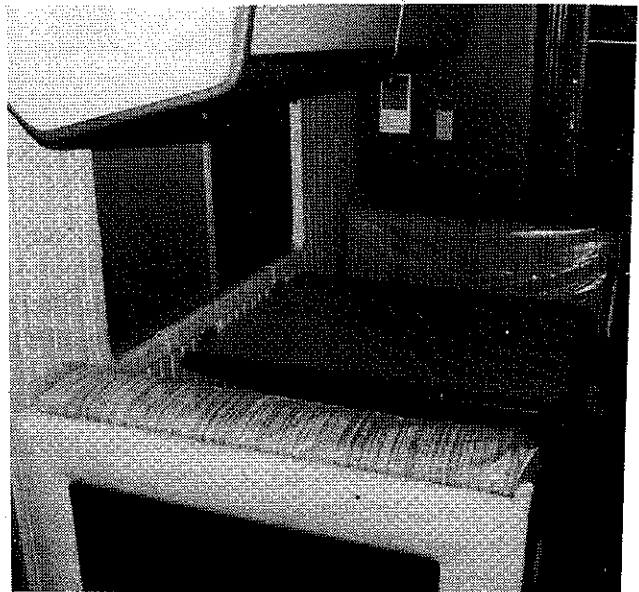

Figure 3-2. Dinette Area

Galley Facilities

The galley, figure 3-3, includes a double sink, food center, toaster, refrigerator/freezer, gas range and oven, and systems monitoring/control panel. The refrigerator operates from the LP gas supply, from the 120 volts ac supply, or from 12 volt alternator output while in transit. The range and oven also operate from the LP gas supply. Operating procedures for these appliances given in the following paragraphs assume that the main LPG valve is on. An LPG leak detector, located below the refrigerator door, continuously monitors the area for LPG leakage, shutting off the LPG supply and sounding an alarm if leaks are detected.



Figure 3-3. Galley Facilities

Refrigerator

Understanding just how the refrigeration process operates will help to explain one of the important reasons why it is necessary to level a parked motorhome. The gas-fired (or electrically-heated) boiler converts the ammonia-water solution to distilled ammonia vapor, which is carried to the finned condenser, where it liquifies. The liquid flows to the evaporator, where it creates a cooling effect by evaporating into a circulating flow of hydrogen gas. If the evaporator coil is not level, the liquid accumulates, forming pockets which do not readily evaporate and impair or block gas circulation, inhibiting the cooling process.

When the coach is parked, it must be leveled to assure comfortable living accommodations. The refrigerator will then also perform well. Place a bubble level (furnished with unit) on the freezer shelf. When the vehicle is moving, the continuous rolling and pitching movement will not affect the refrigerator as long as the movement passes either side of level; but when the coach is parked, the refrigerator must be level (within 6 degrees).

The operation of a thermostatically-controlled fan in the refrigerator compartment is controlled by the **Refrig Fan On-Off** switch located on the systems monitoring and control panel on rear dinette wall. Refer to figure 3-4 for location of refrigerator controls.

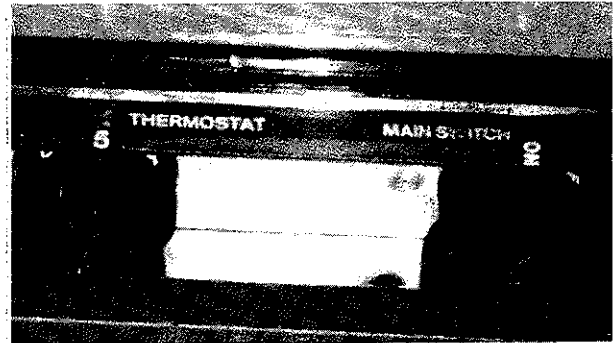

Figure 3-4. Refrigerator Operating Controls

Operation:

Before starting the refrigerator, turn on the gas valves (align arrow and handle with tubing) in the back of refrigerator

1. To start the refrigerator turn knob A to position **On**. Lamp E shall now be green.
2. Turn the thermostat knob B to a suitable setting; try 4.
3. The unit is shut off by turning knob A to position **Off**.

This refrigerator is equipped with an automatic energy selector system. The control system selects the most suitable available energy source. The selection will be made with highest priority to 120 volt. Second priority is to 12 volt from the alternator (when so connected), and lowest priority is gas operation. No manual operation is necessary for change of energy. If the unit does not succeed in lighting the gas the lamp E will change from continuous green into red flashing light. Further information is given below under the heading **red flashing light**. If the battery voltage drops, the control system will start continuous gas operation. The lamp will not be lit. The thermostat will not be in operation. When the voltage increases, normal operation will start up again.

During normal operation, the control system shuts off the gas when correct temperature is obtained. The gas flame will be lit by the control system when the temperature increases above the preset one.



Delay for Gas Start Up

In order to avoid a gas-flame at gasoline stations the refrigerator is programmed to delay gas start up for about 30 minutes after 12 volt operation. Please observe that this delay occurs even after only 1 minute of 12 volt operation from your engine in order to cover events when you have to wait in line for a gasoline pump. If you want a quick gas start up after 12 volt operation you can switch **Off** the refrigerator for a few seconds and then switch back to **On**.

Note

This operation is only available when the refrigerator is connected for three-way use.

Red Flashing Light

If the lamp E begins to flash with a red light, the refrigerator control system has tried to light the gas flame but did not succeed in doing so. We recommend the following operations:

1. Turn knob A to position **Off** and back to **On** again. The lamp shall now be green as the control system makes a new starting attempt. If the refrigerator has not been in operation for a while, or you have just refilled with gas, this operation may have to be repeated several times. Each start attempt will last for up to three minutes. If the starting is not successful the lamp will turn red again.
2. If operation 1. is not successful, check your gas supply.
3. If you have gas – make sure that all valves in the gas pipe are opened.
4. If none of these operations are successful contact a service center.

Selection of electric operation is not blocked during display of red flashing light. Provide electrical power (120 volt ac or alternator) to maintain cooling when LPG operation is unavailable.

Food Storage Compartment

To maintain required low temperatures for food storage, the food storage compartment is completely closed and unventilated. Consequently, foods having a strong odor, or foods liable to absorb odors, should always be covered. Cover veg-

etables and salads to retain crispness. The coldest locations within the refrigerator are beneath the cooling evaporator and on the lowest shelves; the least cold locations are on the upper door shelves. Consider this when storing different types of food.

Defrosting

Shut off the refrigerator.

Empty the refrigerator leaving the drip tray under the finned evaporator and the cabinet and freezer doors open. If desired, defrosting may be speeded up by filling the ice trays with hot water and replacing in the freezer.

When all frost is melted, dry the interior of the refrigerator with a clean cloth. Empty the drip cup at the back of the refrigerator which is reached through the lower side vent.

Replace the drip cup and ice trays. Replace all food stuffs and turn on the refrigerator.

Frozen Food Compartment

Quick-frozen soft fruits and ice cream should be placed in the coldest part of the compartment, on or just below the shelf. Frozen vegetables may be stored in any part of the compartment.

The freezer compartment is not designed for deep or quick freezing of foodstuffs. Meat or fish foods, whether raw or prepared, provided they are pre-cooled in the refrigerator, can be stored in the frozen food storage compartment about three times as long as in the normal temperature compartment. To prevent dehydration, keep food in covered dishes, in plastic bags or wrapped tightly in aluminum foil.

Ice Making

Place ice trays in direct contact with freezer shelf for fastest ice making. Fill trays with water to within 1/4 inch from the top. To release ice cubes grasp the tray with both hands and twist. Return unused cubes to the tray. Refill tray with water, dry outside, replace in frozen storage compartment. Clean compartment with dry cloth.

Refrigerator Shutdown

To shut off the refrigerator turn the knob A to **Off** position. If the cabinet is not in operation over a period of weeks, it should be emptied and cleaned and the door left ajar. The ice trays should also be dried and kept outside the cabinet.



Cleaning

Clean cabinet interior lining with a lukewarm weak soda solution. Clean evaporator, ice trays and shelves with warm water only. **Do Not** use strong chemicals or abrasives to clean these parts or protective surfaces may be damaged. Always keep cabinet clean.

Gas Range and Oven

The gas supply for the range burners and oven, figure 3-5, is provided from the LPG tank. Make sure that the main valve (on tank) is turned **On** before lighting pilots. The appliance valve, marked **Range**, in the refrigerator vent compartment must be turned **On** as well as the valve at the range top connection.

Caution

It is a good safety practice to leave oven control in **Off** position (maximum clockwise) when oven is not in use or while unit is in motion.



Figure 3-5. Gas Range and Oven

Lighting Pilots

To light range and oven pilots, set oven control to **Oven Pilot On** position then hold a match to oven pilot (located above and to the right of oven main burner). Range top must be raised for access to valve for range pilot.

Lighting Range Burner

Once the range pilot is lit, light the desired range burner by pushing in and turning the respective burner control knob counter-clockwise.

Lighting Oven Burner

Once the oven pilot light is lit, turn oven control to desired temperature setting and oven burner will light automatically and maintain correct temperature.

Note

There will usually be a short delay (30 to 40 seconds) after the oven is turned on before the burners will light. This is a normal condition and is not a sign of an oven malfunction.

Shut Off Range and Oven Burner

Turn oven control to **Off** position (maximum clockwise). Turn range pilot off.

Galley Sink

The heavy-gauge stainless steel sink provides maximum durability with minimum care. After use, rinse sink thoroughly with warm water and wipe dry with a cloth to avoid streaks and spots. For stubborn stains, a mild abrasive cleaner can be used with care. Be sure to wipe in the direction of the steel finish to help maintain the original appearance. Always wash counter surfaces before applying a complete wax coating; regular cleaning prevents wax buildup.

Boiling water will not harm stainless steel; however, salt, mustard, ketchup and other similar food acids can cause pitting. If any of these are spilled on the surface, clean off immediately.

Food Center

A built-in variable-speed motor-driven counter unit, figure 3-6, may be used with mixing and blending attachments for a large variety of food preparation tasks. The food center is designed for



ac operation and is operable only when the generator is on; or when coach systems are connected to an external shoreline hookup.

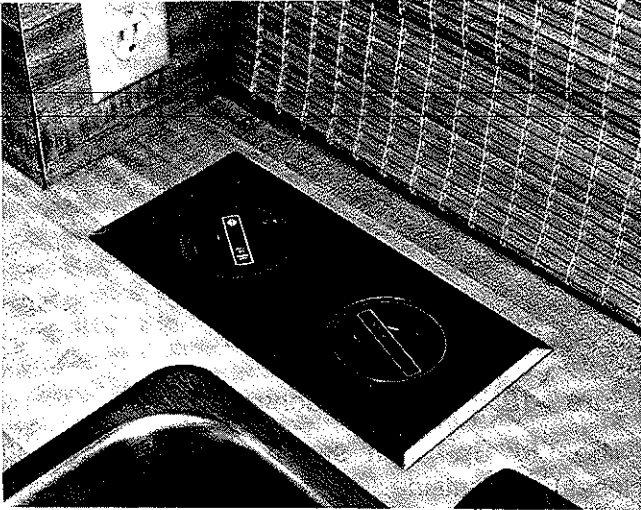

Figure 3-6. Food Center

Toaster

A two slice toaster is built in directly to the rear of the food center. After opening the door, the toaster can be run forward on its track by momentarily pushing the handle to the rear.

Bathroom

Water Pump Switch

Two **Water Pump On-Off** switch/indicators are provided for separate control of water pump operation. One switch is located on the control panel in the galley area; the second is located in the bathroom. The pump may be operated **On** or **Off** from either location. The associated indicator is lit whenever power is being supplied to the pump. Setting either switch **On** pressurizes the water system, with the pump operating on demand to maintain constant pressure. Continuous or erratic pump operation can indicate an empty water tank, system leakage, or air lock in hot or cold water lines. (Air locks are normally caused by movement of water in the tanks during pump operation.) Since tank water level and water pressure can vary with road movement, leave water pump switch **Off** while the coach is moving. The water pump and air accumulator are located in the bed base cabinet.

Tub/Shower Unit

The combination tub/shower unit, figure 3-7, includes a pressure-balancing single mixing valve, tub water spout with shower head diverter button, shower head and drain lever.

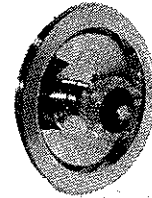

Figure 3-7. Shower Stall

Toilet

The toilet, figure 3-8, operates from the fresh water supply, flushing wastes directly into the sewage holding tank. The double-flush foot pedal located at the bottom of the bowl controls the amount of water delivered into the bowl and opens the sliding valve to the tank. After use, depress bowl drain pedal until water swirls, draining wastes into tank, then release pedal. A water-saver feature, consisting of a manually-operated spray hose, is located at the side of the bowl. To raise the level of water in the bowl, press on the small foot pedal.

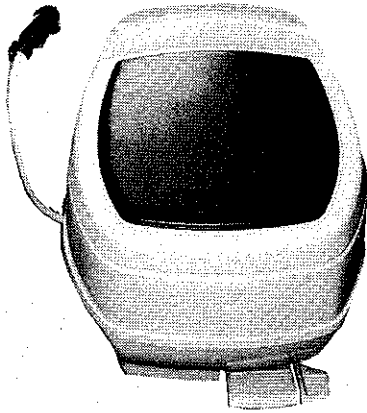

Figure 3-8. Toilet

Roof Vents and Exhaust Fans

Lighted exhaust fans in the living room and bath, figure 3-9, are controlled by respective switch panels. A typical panel, shown in figure 3-10, includes switches for **lid**, **light**, and **fan** control.

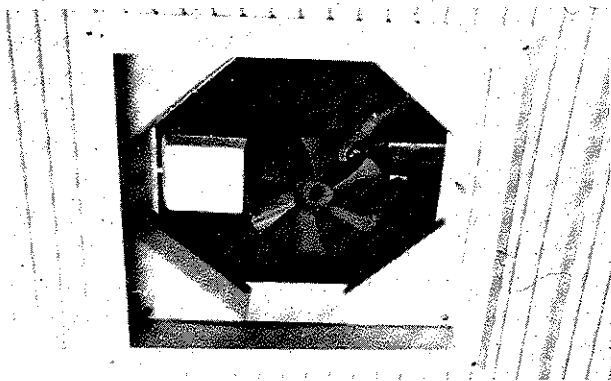

Figure 3-9. Lighted Vent/Exhaust Fan

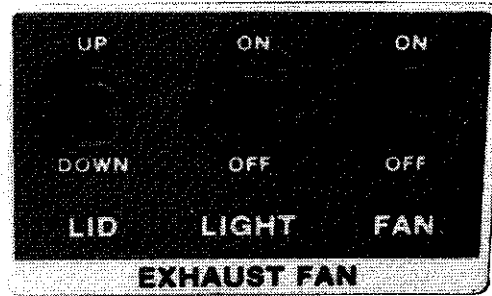

Figure 3-10. Exhaust Fan Control Panel

The **Lid Up-Down** switch raises or lowers (closes) the outside lid, the **Fan On-Off** switch controls fan operation; and the **Light On-Off** switch controls the operation of the built-in ceiling light.

Bathroom

In addition to the exhaust fan previously described, with control panel above the lavatory, a combination vent/exhaust fan is included in the ceiling above the tub/shower. To operate the vent/exhaust fan, figure 3-11, push up on handle to open roof vent, then press switch to turn on fan motor.

Kitchen

Another combination vent/exhaust fan (figure 3-11) is installed in the ceiling above the range. Operation is the same as the fan in the shower.

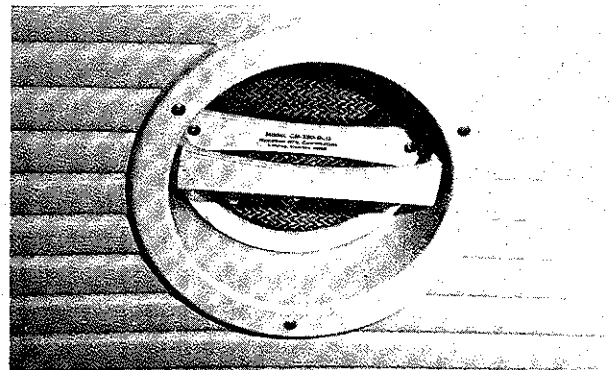

Figure 3-11. Bathroom Shower and Kitchen Vent/Exhaust Fan



Heating Systems

Three types of comfort heating systems are used in your motorhome: gas/hot air heat; electric heat; and engine hot water circulating heaters.

Three gas/hot air furnaces are used in the coach. Each unit has a separate zone thermostat, figure 3-12.



Figure 3-12. Heater Thermostat

One furnace is located in the living room, another is in the galley area, and the third in the bedroom. The living room furnace is also used to supply hot air to the bathroom via a separate duct booster fan controlled by a thermostat in the bathroom.

Separate heating can also be provided by circulating hot-water heaters (chassis heaters) which function through engine coolant heat exchange when the engine is operating and the **Winter-Summer Heat Selector** switch (located on the upper left auxiliary dash) is in **Winter** position. These heaters share the area thermostat with the L.P.G. furnace.

Four electric convection heaters (120 volt) are located in the bedroom, bathroom, galley area, and living area. **On-Off** thermostat switches are located on each heater. Two freeze-protection heaters (120 volt) are installed to protect plumbing and water supply tanks.

Note

Bathroom electric heater is standard; others are optional.

Gas/Hot Air Furnaces

To operate the furnaces, **L.P. HEAT** switch on dash must be **ON**. Proceed as follows:

1. Turn manual gas valve (at furnace front) to **Off** position.
2. Set thermostat above room temperature. A 10 second delay will occur before the blower starts.
3. Allow blower to run for five (5) minutes for combustion chamber purge cycle.
4. After five (5) minutes, set thermostat to the **OFF** position.
5. Turn manual gas valve to **ON**.
6. Set thermostat on desired temperature.
7. Allow 24 seconds for ignition to occur.
8. If burner does not light, set thermostat on **OFF** and repeat steps 1 through 7..
9. If after three (3) attempts with no ignition, go to shutdown and contact a qualified service agency. Do not continue to cycle furnace through thermostat in an attempt to get ignition.

When coach temperature drops below the thermostat setting, the internal relay contacts close to operate the main burner. The air flow created by the blower closes an air-actuated switch that, in turn, energizes the main burner gas line solenoid valve which then lights from the electronic ignition.

Caution

Do not store items in or near the burner compartment.

When the coach temperature exceeds the thermostat setting, the relay contacts open. This shuts off the burner gas supply but the blower continues to operate until residual heat within the furnace is dissipated, when a thermostatically-controlled relay turns off the blower. Air for the sealed combustion chamber is pulled in from outside the coach, routed around the heat exchanger, then exhausted through the outside vent. Recirculated fan-forced air blowing across the heat exchanger is used to heat the coach interior.

Switch at bottom of thermostat must be **Off** (to left) if operation of furnace at lower temperatures is not desired.



Hot-Water Heating Systems

Four sources of hot water heating are provided which depend on heat generated from engine operation. One heater (90,000 BTU), which serves the pilot's and co-pilot's area, is controlled by the **Front Heat** switch on the dash. Three chassis heaters, (50,000 BTU) under the dinette seat, living room sofa, and in the bedroom are controlled by the thermostat in that area.

The bathroom chassis heater (15,000 BTU) is controlled by the bathroom thermostat.

The engine coolant is normally routed through the engine cooling system and the water heater, which also can be heated electrically, to provide the hot water supply for the coach. However, by operating the **Winter-Summer Heat Selector** switch, the engine coolant can also be diverted through the previously-mentioned area heaters, via a solenoid valve. The coolant level in the engine radiator should be checked after these valves are opened. A pump is used to circulate hot water through the coolant lines. It is controlled by the **Aux. Pump** switch (located on the upper left auxiliary dash).

Chassis heater blower motors (dinette seat, front sofa and bedroom), are controlled by **On-Off Heat** switches adjacent to the heater louvers. **Hi-Lo** blower speed switches are also provided. The front heater is equipped with three squirrel-cage dual-speed blowers, operated from separate dash controls. One blower provides defroster air; one provides air to the pilot's side; the third provides air to the co-pilot's side. Use **Defrost Hi-Off-Low** switch for setting the defroster blower speed; use the left and right **Hi-Off-Low Heat** switches to control air flow to the pilot's and co-pilot's sides, respectively. To supply heat, the dash **Front Heat** switch must be **On**.

Note

If additional defrosting action is needed, turn auto air conditioning temperature control to the warmest position and turn auto air conditioning fans to highspeed. This will circulate additional warm air about the windshield area.

Engine heat is picked up by the engine coolant which is pumped through the heaters inside the

coach and back into the engine. A typical heater consists of a heat exchanger, or core, and a fan which moves the air across the core, transferring heat from the engine coolant into the room.

Heating System Operation

Satisfactory performance of the hot-water circulating type of heating system depends on the following conditions:

1. Engine Coolant Temperature — Coolant temperatures vary between 180 and 195 degrees F, during normal engine operation.
2. Coolant Flow — Coolant flow varies with the engine speed. Setting the **Aux. Pump** switch (located on the upper left auxiliary dash) to **On** turns on the auxiliary pump to increase the coolant flow through the system.
3. Proper Fan Operation — All fan motors are two-speed and can easily be checked for proper operation by listening to the motor speed change as the switch is operated.

More heat will be generated by the engine when it is also used to move the coach. Be sure that the engine radiator is full and that all coolant flow valves are open. Warm engine to operating temperature and set heating system switches as follows:

- 1) **Winter-Summer Heat Selector** to **Winter** position;
- 2) **Aux. Pump** to **On**;
- 3) **Front Heat** switch to **On**;
- 4) Left and right **Heat** blower switches to **Hi** or **Low**;
- 5) Thermostats to desired temperature.

Duct Booster

The duct booster system, installed in the hot air duct between the living room furnace and bathroom, is controlled by a separate thermostat in the bathroom. The hot air vent is located at floor level, below the bath tub seat. Note that the living room furnace must be running for the duct booster to operate.

Electric Heaters

Optional electric forced-air heaters (120 volts) are located in the bedroom, bath (standard), galley and living room areas. Each heater is controlled by a combination **On-Off** switch/thermostat. Heater



operating voltage is provided from the same switches which control the air conditioners. Air conditioner **On-Off** toggle switches, on the TV control panel above the pilot, must be in **On** position and individual **A/C** switches **Off**.

Freeze Protection Heaters and Heat Tape

Optional freeze protection heaters (120 volts) are thermostatically-operated to turn on and protect the water supply tanks and associated plumbing in the event that temperatures drop below 40°. Two heaters are used; under the kitchen sink and within the bed base cabinet.

Two thermostatically controlled heat tapes (120 volts) are run on the copper water tubing and then wrapped with insulation. The heat tape for the kitchen/bathroom is plugged into the refrigerator receptacle as is that for the bedroom. Heat tapes start to heat at 36°F and stop at 43°F.

Note

This freeze protection will greatly decrease the chances of frozen water lines provided the coach is plugged into outside power (one 50A. or two 30A. power cords) or the generator is run continuously during cold weather periods.

Hot Water Supply Heater

The electrical hot water supply heater has a 10-gallon capacity and the heater core is also a part of the engine cooling system loop. When the engine is operating, the heat exchanger ensures a constant supply of hot water at about 150 degrees F. In addition, the water supply can be electrically heated by electric coils in the heater unit. The 120 volt, ac-operated, heater is controlled by an **On-Off** pilot switch in the bed base front. This heater can be operated only when the shoreline is connected, or when the generator is running.

Caution

Be sure that the electric heater element is turned Off if there is insufficient water in the tank.

Dry Tank Switch – Water Heater

In order to preclude the possibility of water heater element burn-out, a dry tank sensor circuit has been added in 1984 model coaches

This circuit consists of a sensor in the outlet of the hot water tank which sends a signal through a printed circuit board to energize a relay whenever the tank is not full.

When the 12 volt coil of the relay is energized, it breaks the 120 volt ac circuit to the heater element.

Central Air Conditioning Systems (Standard 35 foot Coaches)

Conditioned air is maintained throughout the coach by three interior 14,000 BTU air conditioner units. Each unit provides variable-speed fan cooling operation for high velocity air movement though individually-controlled outlets. Air conditioning cool-down occurs faster if all windows, doors, and vents are closed after initial purge of warm air.

Maximum air conditioning efficiency also depends on the outside temperature and operating voltage level. Because the air conditioners represent the largest load for the electrical system, never start more than one unit simultaneously. (Air conditioner starting current can be much greater than the normal operating current.)

Caution

To ensure the full efficiency of the air conditioning units, periodic removal and washing of the air conditioner filters is recommended. This is easily done by removing the filters from the retaining screens, washing in a warm soapy solution, rinsing and drying with paper toweling, then replacing filters and screens.

If an external ac hookup is being used, and the system is not operating efficiently, this may be caused by low shoreline supply voltage or a low-amperage-rated supply. (Check power line voltage monitors.) Starting the generator and switching over to generator operation will supply enough power to ensure correct air conditioner operation.

Before starting the generator, check that each



air conditioner is off to prevent the generator from starting under load. Allow generator to warm up to the proper voltage and frequency before turning on the air conditioner(s).

The ac power supply to each air conditioner control panel can be remotely switched **On** or **Off** from the driver's compartment by the **Front A/C**, **Center A/C** or **Rear A/C** toggle switches located in the control panel above and to the left of the driver. These toggle switches operate 12-volt dc relays which, in turn, control the 120 volt ac supply to the respective central air conditioner units. Once the remote switches are **On**, each air conditioner can be controlled locally from its own control panel. Note that the individual heater switches throughout the coach must be in **Off** position before operating the air conditioners.

Control Panel

A typical control panel for a central air conditioning unit is shown in figure 3-13. Operation is as follows:

Off-Start-Run Switch — Applies power to system for fan operation (**Start** position); and next activates compressor (**Run** position).

Note

Do not turn the compressor off and on without allowing a few minutes delay between switching. This will prevent overloading the compressor motor.

Fan Switch — Variable-speed fan motor control. Set as desired for normal operation; set between mid-range and **High** for higher cooling capacity.

Thermostat Control — Clockwise rotation provides greater cooling; set as desired.

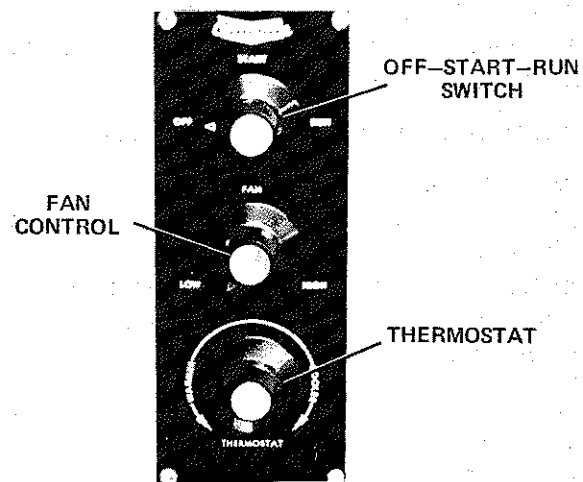

Figure 3-13. Air Conditioner Controls

Systems Monitoring and Control Panel

The systems monitoring and control panel, figure 3-14, is located on the rear galley wall. This one panel provides a convenient means of displaying inside and outside temperature, time, level of potable water supply, holding tanks, and LPG supply, as well as other monitoring and alarm functions discussed in the following paragraphs.

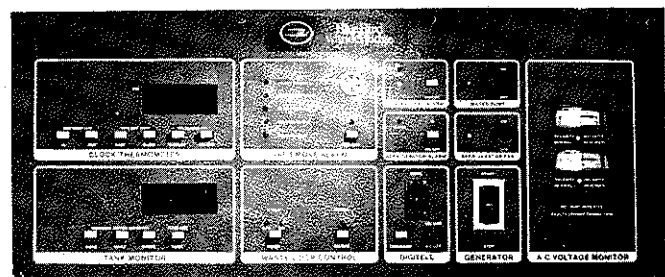

Figure 3-14. Systems Monitoring and Control Panel

Clock/Thermometer

The clock/thermometer, figure 3-15, provides, on demand, a digital display of inside and outside temperature, digital time display, and an alarm function. Operate the panel controls as follows:

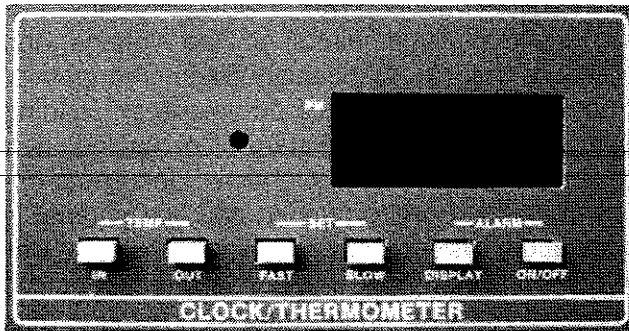

Figure 3-15. The Thermometer and The Clock

1. Monitor inside or outside temperature ($^{\circ}\text{F}$) by pressing the **Temp In** or **Temp Out** buttons. There is an internal adjustment, at the rear of the unit, which may be used to calibrate the temperature readings. (Calibration of this unit is described in Section VIII.)
2. Set the clock by depressing the **Fast** or **Slow Set** button until the correct time is shown. **PM** is indicated by lighted dot in the upper left corner. The dot in the center of the display marks the seconds.
3. Set alarm as follows: depress **Alarm Display** button then depress the **Fast** or **Slow** button to set the alarm time. Dot in upper left corner will light when alarm is set for **PM**. After setting the alarm, release **Alarm Display** button to return to the normal time mode. To activate the alarm feature, depress **Alarm On/Off** button to **On**; to shut off the alarm, depress **Alarm On/Off** button and release so it pops out to **Off**.

Note

When 12 V. power has been interrupted (batteries disconnected or Electronic Master switch turned off) clock display will flash "12:00". Reset clock to eliminate flashing. Alarm will also have to be reset.

Tank Monitor

The Tank Monitor panel, figure 3-16, provides an illuminated readout of the content level of the pure water, gray and waste water tanks, and the LPG tank level. When full, each of these tanks has the following capacity: pure water supply, 96 gallons (See Table 8-4); gray water holding tank, 56

gallons ; body waste tank, 50 gallons (40 gallons for 31 and 33 foot coaches); and LPG tank, 43.5 gallons (148 lb.). Use the features of this panel as follows:



Figure 3-16. Tank Monitor Panel

1. Monitor **Pure**, **Gray** or **Waste Tank** levels by depressing the respective button. The content level remaining in the tank is indicated by five sets of lit readings. The E lamp, at the left of the display, is lit all the time; if the next indicator is lit, the level is approximately 1/4 tank; if the center indicator is lit, tank level is between 1/2 and 3/4 full; if the 3/4 indicator is lit, tank level is between 3/4 and full; and if the F indicator is lit, tank level is full. If only the E indicator is lit, the tank level is between empty and 1/4.
2. LPG tank level can be monitored in the same manner as the water tank level by depressing the **Propane Tank** button. Note that this display is pre-calibrated. However, if it is necessary to recalibrate the display, this can be done when the tank is full by setting a rear-panel adjustment. Note that the display will read **Full** when the LPG tank float reads 80% because the remaining 20% volume is needed for expansion.

Gas/Smoke Alarm

The gas/smoke alarm, figure 3-17, is a gas leak detector designed to sense dangerous concentrations of LP gas or carbon monoxide within the coach. There are four (4) sensors mounted at floor level (LP gas is heavier than air) for the three furnaces and the refrigerator. One sensor is located above the 120 volt ac distribution panel (load center) to monitor carbon monoxide. Carbon monoxide, of course, is the most deadly of the



products of combustion. It will provide an alert in the event of a short circuit, at the load center, causing an electrical fire.

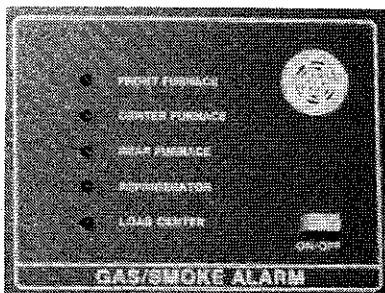

Figure 3-17. Gas/Smoke Alarm

The alarm has been factory-calibrated to an alarm point of 2,000 PPM propane for standard conditions (temperature, 20 degrees C \pm 2 degrees; relative humidity 65% \pm 5%). This provides for a minimum of false alarms consistent with providing reasonable safety.

The sensors have a long life and high reliability. In normal use, recalibration or replacement will not be necessary for 5 years or longer.

To turn on the unit, set **On-Off** switch to **On** and observe that **Power On** indicator is lit. Excessive propane PPM conditions are indicated by the sounding of the audible alarm and lighting of an indicator associated with the danger area. The alarm, if left turned off for a period of time, has a warmup period of about one minute. During this time, the alarm may sound. This is a normal response and should stop once the unit is warm.

A/C Voltage Monitor

The dual-channel power line monitor, figure 3-18, continuously monitors ac line voltage and shoreline hookup(s) polarity. Each channel includes an expanded-scale ac voltmeter, reading from 90 to 130 volt ac, a **Polarity Normal** indicator (green), lit whenever the shoreline hookup is properly connected and grounded and line polarity is compatible with coach wiring and a **Polarity Reversed** indicator (red) which lights when hookup is reversed. Note that shaded area on the meter face indicates normal voltage range.

A faulty ground connection is indicated if none of the LEDs is lighted.

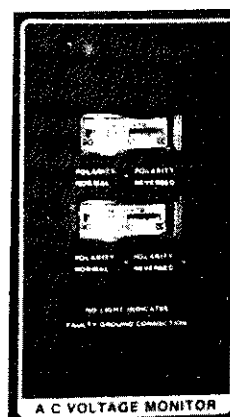

Figure 3-18. A/C Voltage Monitor

Waste Odor Control Panel

This panel, figure 3-19, controls the cycling and electrolysis action of two pairs of stainless steel electrodes contained within the body waste holding tank. A 12-volt current is passed between each pair of electrodes for a 16-minute **On** period (green LED); and switched off for a 48-minute **Off** period (red LED). For each cycle, the current is reversed so that the electrolytic action does not excessively erode the steel electrodes.

As current flows through the waste liquid, it oxidizes the organics and eliminates associated odor. To increase odor control effectiveness, a tablespoonful or two of salt may be added through the toilet if desired.

The electrodes (probes) are replaceable.

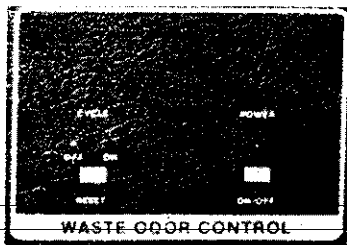

Figure 3-19. Waste Odor Control Panel

Digitell Monitor

The Digitell is a verbal information system that supplements a number of informational and warning indicator components.

In addition to the main control center at the dinette, Figure 3-20, command stations are located near the pilot and co-pilot, in the bathroom and in the bedroom overhead panel.



Figure 3-20. Digitell Control Center

Operating features are selected by a ten-position thumbwheel with functions as follows:

Switch

Position / Function

- 0 / Set Hours for Time
- 1 / Set Minutes for Time
- 2 / Set Hours for Alarm
- 3 / Set Minutes for Alarm
- 4 / Time on Command
- 5 / Time on Command with Alarm
- 6 / System Functions/Time on Command
- 7 / System Functions/Time on Command/with Alarm
- 8 / Elapsed Time
- 9-F / Not used

Note that positions 1 through 5 apply to time-keeping functions which operate continuously and are independent of the remaining functions.

Set in **Time** in hours by setting the thumbwheel

switch to 0 position, then press the pushbutton until the correct hour is announced. Repeat for minutes (switch position 1), alarm hours (switch position 2) and for alarm minutes (switch Position 3). Announce **Time** by setting the thumbwheel switch to position 4 and press the pushbutton. Announce **Time** and **Alarm Time** by setting the thumbwheel switch to position 5 and press the pushbutton.

Count Elapsed Time by setting the thumbwheel switch to position 8. Press pushbutton once to start time operation, press it a second time to announce the elapsed time. The timer will continue to measure elapsed time from zero (first time pushbutton is pressed) until the pushbutton is pressed twice in sequence. The total elapsed time will be announced and the timer will stop counting.

Systems Monitor Functions are accomplished when the thumbwheel switch is in position 6 or 7. The Digitell will continuously announce an alarm if any of the following conditions exist when the ignition is turned on:

1. Generator door is unlocked.
2. Leveling jacks are still down.
3. TV antenna has not been fully retracted.
4. Shoreline is still connected.
5. Headlights ("driving lights") left on (after ignition is off).

The following conditions are monitored while driving and announced at 45-second intervals:

1. Low fuel level.
2. Water in fuel.

To discontinue an alarm condition, push the command switch at any Digitell speaker command location during the announcement. (Digitell speakers are recessed behind overhead cabinetwork.)

Generator Switch

The generator **Start-Stop** switch, figure 3-21, provides the same features as the generator switch located above the driver. Press switch to **Start** position and hold until generator starts as shown by the switch indicator light. Press switch to **Stop** to shut-down the generator (light extinguished). Press switch to **Stop** (and hold) for engine pre-heat.



Figure 3-21. Generator Switch
Switch and Monitor Panel

The switch and monitor panel, figure 3-22, monitors the battery voltage level, activating an audible alarm if a low-voltage condition is present (**Low Battery Alarm**). It also monitors the refrigerator temperature when the **Refrig. Alarm** switch is **On**. Normally, the **On** indicator is lit; if the refrigerator temperature increases to an unsafe level, the **Warm** indicator lights with an accompanying audible alarm. The thermostatic refrigerator fan is controlled by the **Refrig. Fan On-Off** switch. The indicator above the switch is lit when power is being supplied to the fan. However, the fan will not operate until vent column temperature reaches approximately 100 degrees F.

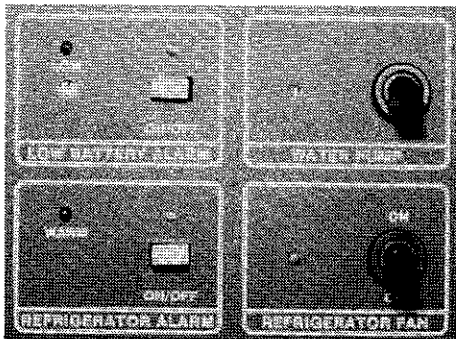

Figure 3-22. Switch and Monitor Panel

Water pump operation may also be controlled from this panel with the **Water Pump** switch; the **On** indicator will be lit when power is being supplied to the pump.

LP Gas Leakage Detector

The gas leakage detector, figure 3-23, is located below the refrigerator door. In the event of an LP leak, the unit sounds an alarm and closes down the main LPG supply by activating the leak detector

solenoid shutoff valve located in the gas line just after the low pressure regulator. If it is necessary to reset the solenoid (red band is visible inside clear plastic valve housing), open the outside refrigerator vent compartment door, remove plastic housing by gripping locking levers and lifting upward, push valve plunger down until it remains down, then replace the cover. For continuous operation of the leak detector, set **Off-On** switch **On**; to test alarm operation, press the test switch located on top of the detector unit. Alarm must sound for at least 15 seconds before the shutoff valve will be activated.

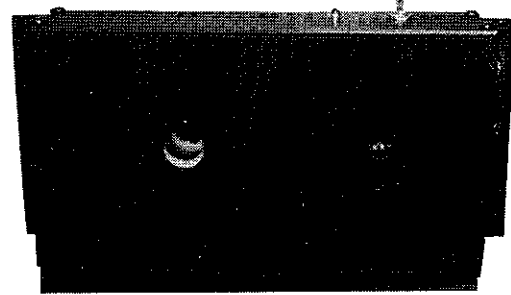

Figure 3-23. LP Gas Leakage Detector

Electronic Door Chime

The door chime, figure 3-24, is located on the rear dinette wall.

The door chime can be preset to play any one of 60 different tunes when the doorbell button is pressed. As shown, all controls for tune selection, volume, tone and tempo are easily accessible. Tunes may be selected as follows:

1. Refer to tune index, at bottom of chime, and note the code number for the desired tune. For example, "William Tell Overture" is identified by D8.
2. Press in the left-hand tune selector button and move it to position D.
3. Press in right-hand button and move it to position 8.
4. Press test button to play selected tune and adjust volume, tone and tempo as desired. Note that tunes identified with an asterisk (*) will play longer if the button remains depressed.



Caution

Do not use a lighted door button with this chime or chime may be inadvertently activated.

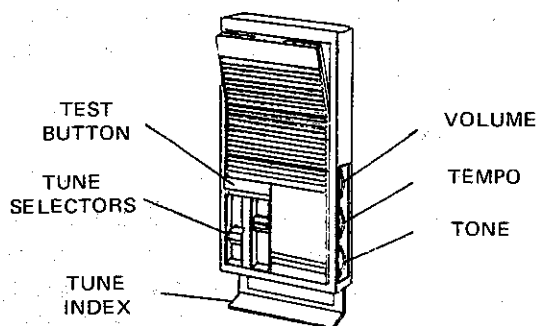

Figure 3-24. Electronic Door Chime

Portable Fan

The portable oscillating fan is shown in figure 3-25. The 12-volt hookup cable is coiled within the base section when the fan is not in use. This will supply air circulation within the coach when it is too cool for air conditioning.

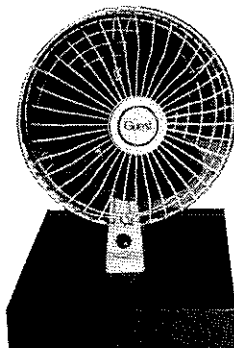

Figure 3-25. Portable Oscillating Fan

Security Timer

The **Watchdog** security timer, figure 3-26, is a randomly-switched electrical timer which can be used to control the on-off operation of an appliance, light, etc., to give your coach that 'lived-in' look when it is unoccupied. The three-position switch may be set to **Off**, to shut off the controlled appliance; to **On**, for manual control; or to **Security**, for random operation.

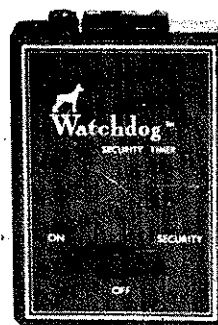

Figure 3-26. Security Timer

Burglar Alarm/Anti-Theft Features

The security of your motorhome and contents are assured by an intruder alarm system which protects windows and entry door. Each window is protected by a magnetic proximity switch which triggers an alarm if the window is opened. The entry door uses a door jamb switch which operates when the door is opened. When the system is **secured** it may be activated from outside the coach by a key-switch adjacent to the entry door. From inside the coach, a master burglar alarm switch may be operated at the front instrument panel.

In addition to the alarm system, an anti-theft switch for the ignition circuits (A/T switch on dash) can be operated so that the unit cannot be started. Lastly, the 12 volt **Master** switch (hidden behind the right side of the dash) can be operated to turn off all but essential 12 volt circuits.

Bedroom Overhead Panel

The bedroom panel is directly above the head of the bed.

It contains two stereo jacks and a volume control, security light switch (illuminates front and rear landing lights, driving lights in front bumper, and rear Halogen parking lights), night (aisle) light



switch, alarm clock, Digitell command station, and entrance door lock.

Most of these are duplicates of previously described controls and are added for your comfort and convenience.

Alarm Clock

The setting procedure for this clock is identical to that on the Systems Monitoring Panel. This clock has a dimming feature and the lighted dot, marking seconds, has been eliminated.

Fire Extinguisher

A portable, multi-purpose dry chemical fire extinguisher is located under the aisle end of the front dinette seat. A second fire extinguisher is located in an outside compartment. To use, release the clamp and remove the fire extinguisher from the bracket, pull safety pin from handle, squeeze handle and apply chemical under flame.

Intercom System

The optional intercom system used in your motorhome, figure 3-27, is a master-to-master system so that any station can originate calls to any other station. Just lift the handset, push in the button corresponding to the called station, and carry on your conversation. Intercom stations are located on the floor to the left of the driver, in the bathroom, dinette, and on the rear bedroom wall.



Figure 3-27. Intercom System

Stepwell Area

The stepwell cover is hand operated and is retained in the upright (stowed) position by two latches.

The **Step** and **Step Light** switches are accessible after opening the door of the stepwell compartment, figure 4-3.

The **Step Light** switch makes it possible to turn off the step lights if the step is to remain in the extended position for a time.

If it is desirable for the step to be left in the extended position, for repeated trips into the coach, the **Step** switch may be used.

Smoke Detector

A smoke detector (now code mandated) is installed in a ceiling location just outside the entrance to the bedroom area. Operator instructions are attached inside the overhead cabinet where the warning label is displayed on the exterior door trim.

It is possible for the smoke detector to be activated by the cold air coming from an Air Conditioner outlet. Slight downward rotation of the outlet louvre is all that is necessary to discontinue activation.



Section IV

Electrical Systems

There are actually two interrelated electrical systems used in your motorhome: the 12 volt dc supply system; and the 120 volt ac supply system. The 12 volt dc supply system is divided into several branches, or zones, each functioning from the common 12-volt battery source. One branch provides the 12 volts required for the automotive starting, ignition and lighting systems; remaining branches supply those motorhome circuits and appliances which require 12 volts dc for operation.

The 120 volt ac system includes those motorhome appliances which require 120 volts for their operation, supplied from either the internal generator; or from the external 120 volt ac (or a split 240 volt ac) supply, via the shoreline hookup; or from the battery-powered 120 volt motor generator unit.

12-Volt DC Supply System

Wiring diagrams of the 12-volt supply and distribution system are included in Section X.

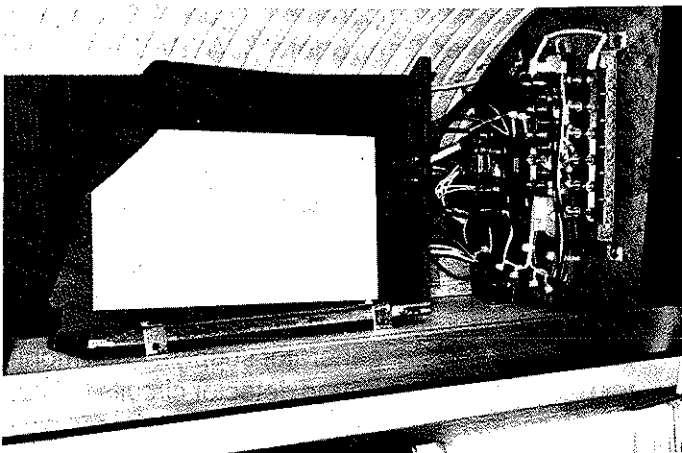

Figure 4-1. Typical Load Center

The 12 volts supplied to all motorhome appliances, outlets and accessories is routed from the batteries through a main 12 volt master switch and routed through busses to the individual branches, or zones, that are serviced from this supply. Circuit breakers are located behind the access panel at the top front left side of the coach, lower front load

center (behind left headlight panel) and at each of the zones. The circuits supplied and fuse or circuit breaker protection at each zone are shown on a diagram attached to each zone panel. Copies of these diagrams are included in Section X for reference purposes. A typical load center is shown in figure 4-1.

Battery Heaters

120 volt ac battery heater pads provide faster engine starts during cold weather conditions by increasing the available cold cranking power. Heaters operate only from the ac supply line via the **Battery Heater** switch located on the living room sofa front (behind pilot's seat).

Note

To avoid premature deterioration of the batteries, heaters should be used only when the temperature is below 32°F.

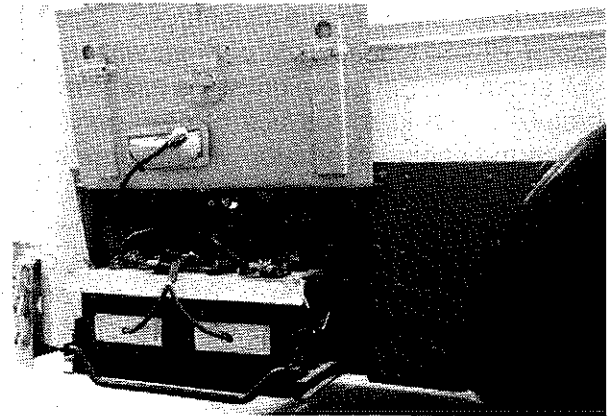

Figure 4-2. Battery Compartment

Battery Chargers

The 12 volt engine battery supply, figure 4-2, (four in this compartment plus two in curb side front compartment, for a total of six) and the generator battery are maintained fully-charged by either the engine alternator (when engine operates); or by two 75 ampere battery charger/converters. These automatic electronic battery chargers operate whenever a source of 120 volts ac is supplied to



the coach circuits. The two chargers furnish a total of 100 amperes of service to the 12v. d.c. motorhome circuits. Chargers are in left (road) side compartment in front of rear wheels.

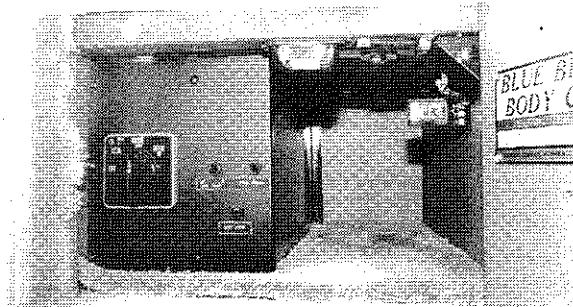

Figure 4-3. Stepwell Compartment

Batteries can become discharged because of coach 12 volt loads, while parked, without a 120 volt ac source. For overnight stops this presents no problem, with judicious use of 12v. service, because the engine alternator will recharge the batteries rapidly during the next day's travel. When operating from shoreline or generator power, the batteries obtain the major portion of the charge during "sleeping" time, while coach loads are low, so that the battery chargers can "top off" the batteries.

If it is planned to leave the coach parked without exterior power for a week or longer turn off the **Electronic Master** switch in overhead cabinet adjacent to left front load center. This will ensure that there is no drain from the circuits which remain on when the **Master** (under dash) switch is **Off** (clock, memory and LPG leak detector).

DC Supply Monitors

The **ENG. AMP. METER**, located on the lower dash, indicates the total current flow from the charging source (engine alternator or battery chargers).

The **CHARGE** ammeter, located on the upper

right auxiliary dash, shows the current flow into the coach batteries.

The **DISCHARGE** ammeter, also located on the upper right auxiliary dash, shows the load drawn by coach circuits.

ENG. VOLT METER, located on lower dash, shows voltage at **Master** switch behind lower dash.

While in transit, this should reflect an alternator regulated setting of 14v. When parked, with 120v. source supplied, this should read between 12.5 and 14.0v. depending upon load. When parked, without 120v. source, do not permit voltage to drop below 11.5.

After a trip, **CHARGE** ammeter will show some discharge reading, even when 120v. source is supplied, if there is a load on the 12v. coach circuits. The **Float** type battery chargers allow a voltage of 12.5-13 when there is a load.

AC Supply System

Motorhome ac-operated appliances are supplied from either an external shoreline hookup or from the on-board generator. Selection of shoreline or generator power source is determined by a four-position ac power selector switch located in the stepwell compartment, figure 4-3. Set this switch to either **Gen**, **Shore 50A**, **Shore 30A** or **Off**, depending on the power source availability. Leave this switch in **Off** position to completely disconnect the motorhome 120-volt ac circuits normally supplied by these inputs.

Power Line Monitors

A dual power line monitor is located on the galley wall to monitor the voltage in both legs of the ac shoreline supply (or generator supply). Each monitor has polarity and ground detector circuits to indicate possible electrical hazards due to incorrect hookups.

In 1985 and 1986 model coaches, a second dual power line monitor is located in the Utility Box (figure 5-1). Now you will know immediately if there is reversed polarity or an unsatisfactory ground in the shoreline source.

AC Circuit Breaker Panel (Distribution Panel)

The main ac circuit breaker panel, figure 4-4, is located in the curb-side closet area.

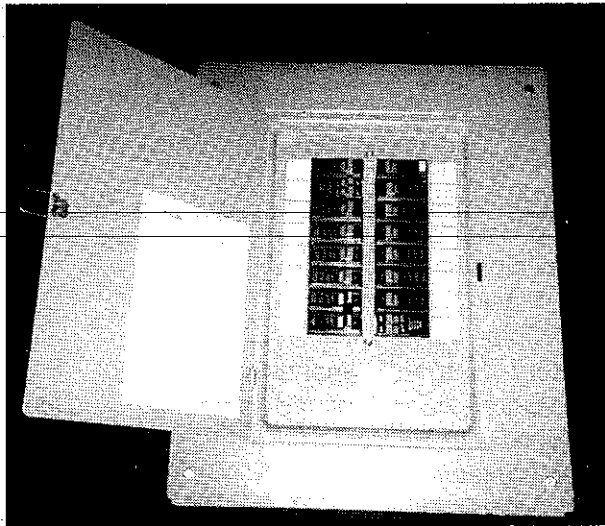

Figure 4-4. Load Center Circuit Breakers

Generator Operation

The generator plant has its own 12-volt starting battery so that it can be started independently of the coach 12-volt batteries.

The generator can be started and stopped from either of two locations within the coach: at the driver's instrument panel; or at the systems Monitor Panel. In addition, the generator can also be started in the generator compartment.

To start the generator, push the **Generator** switch to the **Start** position and hold until the generator starts, as indicated by the generator **On** indicator light. **Do not hold switch on for longer than 5 seconds at a time!** If the generator does not start the first time, wait a minute and try again. Release the switch when the indicator light in the switch glows. The generator may be stopped at any time, from either of the two locations in the coach, or with the **Start-Stop** switch in the generator compartment, figure 4-5, by holding the switch to the **Stop** position until the generator stops (light in switch extinguishes).

In cold weather, it is necessary to activate the cylinder glow plugs before starting. Push **Start-Stop** switch to **Stop** position and hold for 14 to 20 seconds.

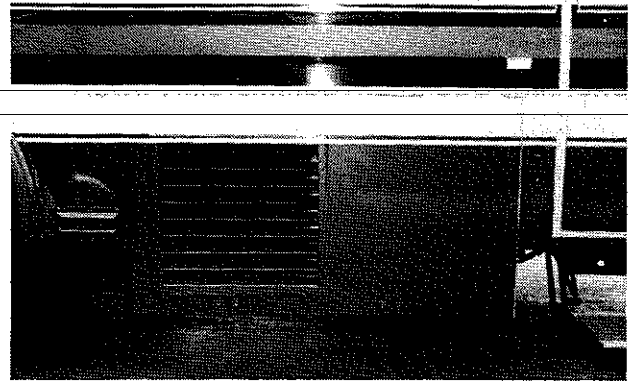

Figure 4-5. Generator Tray

It is not advisable to start the generator under a heavy load, especially with the high current demands made by the air conditioners. This may cause hard starting and possible damage to the generator electrical system. It is a good practice to remember to set the **Main Selector** switch to **Off** (figure 4-3) before turning on the generator so there will be no electrical load on the line. Also, remember to set the selector switch to **Gen** position when the generator is being used; and to reset the switch to either **Off** or **Shore** position, as appropriate.

The generator is housed within an air operated extendable tray which is normally locked into place by a hand-latch located underside, figure 4-5. To open, unlock the latch by moving forward and extend the tray outward by operating the **Out-In Gen. Tray** switch in the stepwell compartment, figure 4-3. **Note: Latch handle for 7.5 K.W. generator is on door exterior and upward movement will unlatch.**

If the ignition switch is turned **On** while the generator tray is still in the extended position, or if the tray is not locked properly, a warning indicator on the dash will light (figure 2-2, item 38), and the Digitell unit will continuously announce — **Secure door on APU.**



Caution

The generator tray is **heavy** and moves in and out with a great deal of force. **Keep Hands Off Tray When Operating Switch!**

Shoreline Operation (Commercial Power)

Set the power selector switch, figure 4-3, to **Off** position **before** the motorhome electrical system and external supply are joined.

Caution

Your motorhome has been wired in accordance with the National Electrical Code. All 120 volt ac wiring is two-wire service with ground; all 240 volt wiring is three-wire service with ground. If the motorhome is connected to an external hookup which has only a two-wire circuit, ground the third wire on the adapter to the external supply metal junction box or conduit. For personal safety, check the polarity detector indicators on the power line monitors to be sure that lines are properly connected and grounded.

For purposes of safety, observe all precautions when making these connections. First, connect the shoreline to the coach (**rotate plug clockwise to assure firm connections**). The coach receptacles are located in the same compartment as the water hookup, in the rear pilot's side, figure 5-1. Connect the other end of the shoreline to the power source. Set the power selector switch to the appropriate **Shore** position. Poor grounding or incorrectly-wired receptacles can cause personal harm as well as equipment damage or fire hazards. Check power line monitors on Systems Monitor Panel to verify correct supply voltage, polarity and grounding of hookup.

In many instances, the shoreline hookups will not be rated to operate all electrical appliances in your coach. Check with facility personnel to determine the maximum current capability of the hookup. Sometimes, only one air conditioner may be operated. The current ratings for appliances designated for standard or optional usage in your coach are listed in table 4-1.

Table 4-1. Electrical Ratings for Motorhome Appliances

Item	Current Rating (Amperes)
Air Conditioners	
14,500 BTU	(Start) 19.0
Water Heater	10.0
Television Receivers	
Black-and-white	.5
Color	1.0
Battery Chargers (depends on battery condition/load)	0 to 12.0
Engine Block Heater	10.0
Electric Heaters	
* "Cheater Heater"	12.5
Battery Heaters	1.2
Heat Tapes	3 watts/ft
* Microwave Oven	14.0
Food Center	4.0
Vacuum Cleaner System	9.0
Refrigerator	2.7
* Ice-Maker	Start 15 Run 2.5
* Washing Machine/Dryer	25.0
* Instant Hot Water	6.5
* Optional Item	

Shoreline Operation — Troubleshooting

Your coach is designed and tested to make sure the 120v. ac **Neutral** (white) wire and the **Ground** (bare copper or green) are not tied together (no continuity). This will prevent any danger of a "hot skin" if the source of power has reversed polarity (red LED lit).

Problem

— Probable Cause

— Corrective Action

Green LEDs lit - Normal (desired)

Red LEDs lit

— Reversed Polarity at power source.

— Convince park management to correct or change lot assignment.

Neither red or green LED lights

— No ground connection with park service

— Use jumper lead from ground pin on shore cord to service box.



Power source (park) circuit breaker trips.

- Reversed polarity in park (or incorrect connections in power cord) along with coach neutral and ground tied together.
- Use on-board generator until qualified electrician can correct coach problem. (Generator polarity is correct).

Green LED's lit plus Red LED's glow when additional load is turned on (Air Conditioner or Water Heater).

- Poor ground connection at park (floating ground).
- Make sure shoreline plug is fully engaged twist locked (clockwise) at coach.

Safeline Alarm

Your coach is equipped with a shoreline disconnect alarm, which is located on the upper left auxiliary dash. This device will provide an audible or visual alarm whenever the shoreline is left connected to the coach at the same time that the ignition switch is turned **On**. This assures that the coach is not inadvertently driven away while still connected to the shoreline hookup. In addition to the Safeline-originated alarm, the Digitell unit will announce continuously that the shoreline is still connected.

Audio System Wiring

Low-voltage audio system wiring is run throughout the coach between the stereo radio, speakers, headphone jacks, volume controls and "booster" amplifiers. These interconnections are shown on wiring diagrams provided in section X.

Electronic Filter

12v. d.c. power for electronic equipment is supplied directly from the coach batteries through an electronic filter (located under the road side living room sofa) to the audio-video systems and monitoring panel. This eliminates electrical noise interference.

Electronic Master Switch

Most of the electronic circuits are de-energized when the main **Master** switch (behind dash) is turned **Off** (relay action). Circuits that still receive power when the **Master** switch is off serve the monitor panel, clocks, radio memory, and LPG

leakage detector. If coach is to be stored for a week or more without external power, the **Electronic Master** switch in overhead adjacent to left front load center should be turned off.

Battery Jumper Terminals

For your convenience and safety when jump starting (usually someone else's vehicle), terminal posts are provided at the top front of the battery compartment, figure 4-2. Utilization of these terminal posts is described in Section VIII.

Battery Storage in Freezing Weather

Batteries that are not kept full-charged must be given protection against freezing. Partially-charged batteries will freeze at low temperatures, so batteries must either be left charged or removed from the vehicle and stored in a warm location.

The motorhome can be left connected to the shoreline ac supply and the coach battery chargers will keep all batteries charged. Note that even in a warm location it is advisable to keep the batteries charged to prevent deterioration. The six main coach batteries should be checked for proper electrolyte level: add water, as required. The battery used for the generator is a sealed battery.



Faint, illegible text in the upper left quadrant.

Faint, illegible text in the upper right quadrant.

Faint, illegible text in the middle left quadrant.

Faint, illegible text in the middle right quadrant.

Faint, illegible text in the lower middle left quadrant.

Faint, illegible text in the lower middle right quadrant.

Faint, illegible text in the lower left quadrant.

Faint, illegible text in the lower right quadrant.

Faint, illegible text in the bottom left quadrant.

Faint, illegible text in the bottom right quadrant.

Faint, illegible text in the bottom left quadrant.

Faint, illegible text in the bottom right quadrant.



Section V

Water Distribution and Drainage Systems

Note

The **Tank Fill** switch should be **On** only when the water tank is being filled. This switch must be in **Off** position at all other times.

Your motorhome is equipped with a completely self-contained water system which includes piping, heating and drainage facilities similar to those used in home installations. The water supply and distribution system includes three networks: (1) a potable water supply system, which includes the water tanks, pump, air accumulator, pressure switch, water purifier and input supply lines; (2) water heater and interior hot water heating systems; and (3) waste, winterizing, quick drain and sewage drainage systems. Refer to Section X for potable water system and plumbing drainage system piping diagrams.

Water Supply and Distribution System

As shown in figure 5-1, the dual purpose **Tank Water Fill/Commercial Water** inlet connection is located in the rear utility compartment. The **Tank Fill On-Off** switch controls a solenoid-actuated water valve to divert the commercial water input to fill the pure water storage tank(s). Located beneath the rear bed(s), the tank(s) are non-pressurized types so that system water pressure is developed by pumping action directly into the supply lines, rather than by tank pressurization. A bacteriostatic water purifier system purifies the cold-water supply to the cold-water taps in the galley sink and bathroom lavatory, ice-maker and Konstant Hot water tap.

Commercial Water Hookup

When facilities are available, the **Commercial Water** hookup can be used to supply all coach water system requirements. In this manner, the coach water tank and pump system is automatically bypassed by the supply line check valve and water pressure is developed by the external connection. Water input pressure is regulated to 40 psi by a valve which is part of the combination city (commercial) water fill, check valve, and regulator shown in figure 5-1.

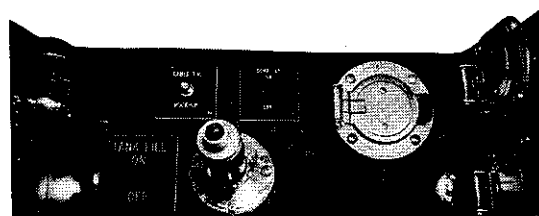

Figure 5-1. Location of Commercial Water Hookup

Filling and Sanitizing

Filling the Tanks — To fill the water supply tanks, connect the water hose to the commercial water inlet, set **Tank Fill** switch to **On**, then turn on the water supply. When the tank is full, as indicated by water overflow beneath the coach, set the **Tank Fill** switch to **Off** position, shut off the water supply and disconnect the hose. At this time, check that the Monitor panel readout on the galley wall indicates a full water tank. To check, press the **Pure** tank switch and observe that the **E** through **F** indicator segments are lit.

Sanitizing the Water System — Water sanitizing procedures should be followed before the system is used for the first time, after long idle periods, where water may become stagnant; or after any suspected contamination of the water supply. Whenever possible, use a commercially-approved tank sanitizer and follow the procedures on the product package. If it is not possible to use a commercial product, prepare your own mixture and sanitize the tank in accordance with the following procedures:

1. **Empty the Water Tank(s)** — To drain tank(s), set the **Water Tank Drain** control (on the control panel in the bed base cabinet) to **Open**, figure 5-2. After tank(s) is completely drained turn **Water Tank Drain** control to **Closed**.

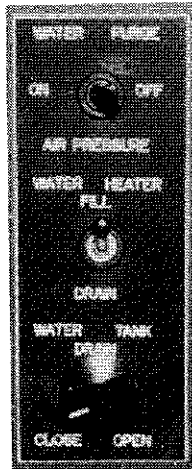

Figure 5-2. Water Purge Air Pressure, Water Heater Drain and Water Tank Drain Controls

2. Prepare the sanitizing solution using $\frac{1}{4}$ cup of household bleach (sodium hypochlorite solution) for each gallon of water. Use one gallon of the solution for each 15 gallons of tank capacity. This procedure will result in a residual chlorine concentration of 50 ppm in the water system. If a 100 ppm concentration is required use $\frac{1}{2}$ cup of household bleach with one gallon of water to prepare the chlorine solution. Seven gallons of solution will be most adequate for the largest tank(s) (100 gallons).

3. Add sanitizing solution to water tank(s) — Disconnect overflow hose from tank(s) and pour solution into vent fitting. A curved piece of $1\frac{1}{4}$ I.D. hose, clamped to the vent fitting, will facilitate this process. Reconnect overflow hose.

4. Fill tanks to Capacity — Connect the hose to the commercial water inlet, set the **Tank Fill** switch to **On** and fill water tank(s) completely. Shut off hose, and set **Tank Fill** switch to **Off**. Turn on water pump. Open each faucet (hot and cold) and run the water until a distinct odor of chlorine can be detected. Shut off water pump.

5. Allow the system to stand for at least 4 hours when disinfecting with 50 ppm residual chlorine. If a shorter time period is desired, then a 100 ppm chlorine concentration should be permitted to stand in the system for at least 1 hour.

6. Drain Tank(s) — Open the **Water Tank Drain** control and allow the tank(s) to drain completely.

7. Refill Tanks — Close the **Water Tank Drain**

control, and turn on the water supply to the commercial water inlet, set **Tank Fill** switch to **On** and fill tank(s) completely. When the tanks are full, set **Tank Fill** switch to **Off**, shut off water supply and disconnect hose, replace fill cap and turn on water pump. When water flows from opened faucets, close them and open other faucets until water flows. This flushes the system, removing trapped air from the piping and ensures that the fresh water supply is ready for use.

Note

Residual tastes or odors can be removed by again draining and rinsing the system with a vinegar solution mixed to the ratio of one quart of vinegar to five gallons of water.

Potable Water Distribution System

The major components of the potable water distribution system are the water tanks, water pump, air accumulator, water heater, piping and fixtures. In addition, a bacteriostatic water purifier is connected in the cold water supply line to the galley sink, lavatory, Konstant Hot tap and ice-maker (option).

The air accumulator and water pump are located below the kitchen counter as shown in figure 5-3. The water purifier is behind location for optional ice-maker, and water tank drain valve is located under the bed.

Water Pump

The water pump, figure 5-3, is equipped with a factory-calibrated pressure control switch which is preset to turn the pump on when the system pressure falls below 20 psi; and turn the pump off when the pressure reaches 35 psi. If the pump has been out of service for a period of time, it is advisable to open a faucet before turning the pump on. When water flows steadily from the opened faucet, close faucet and observe that pump shuts off when system becomes pressurized. (it may also be necessary to bleed the air from the other faucets as well.) When the potable water supply tank(s) level is low, or empty, shut the pump off to prevent possible damage to the pump motor. In addition to integral motor overload protection, the pump mechanism is also protected from jamming by the presence of an inline filter (pump guard) between the pump and the supply tank.

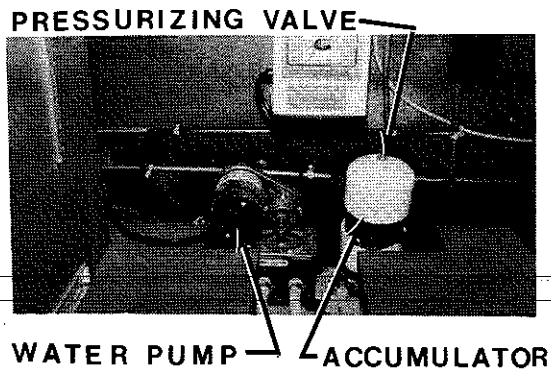

Figure 5-3. Water Pump Location

Water Purifier

The bacteriostatic water purifier filters and purifies potable water to eliminate tastes, odors and coloration produced by chlorine, rust, insecticides, detergents, sediment and other foreign objects. Satisfactory elimination of water-borne disease-carrying bacteria is accomplished by a hygienic filter bed which consists of silver ions absorbed on sponge silver metal which is deposited in a finely divided form on granular activated carbon of high surface area.

An added benefit is that even though the coach is not used for some time, bacteria will not grow in the water distribution system.

The water purifier is a self-contained unit requiring no routine or periodic maintenance.

Each time the filtered water supply is used for drinking or cooking purposes, run the tap for a few seconds to clean out the line prior to using the water. This is particularly important if the water tap is not used on a daily basis. If the water supply has not been in use for extended periods, allow the water to flow for a minute or two before use.

Purifier Replacement — Depending upon the condition of the municipal water used, the filter media will normally process 75,000 gallons of water before the purifier will need to be replaced. For the majority of "Wanderers" this means there will be at least five years of useful life.

The only practical way to determine when replacement is required is to go by the sense of taste. If a faint taste of chlorine is detected, it is time for a change. Even when there is a noticeable taste, the bacteria stopping properties have not been compromised.

Water Heater

The 10 gallon Marine Electric Water Heater has a "motor aid" heat exchanger to ensure a supply of hot water while in transit and upon arrival at your destination. Engine coolant circulates through this heat exchanger as shown in the chassis heater piping diagram in Section X. The electrical heater can be used whenever 120 volts ac is available. The heater switch, located in the bedfront, should be switched **Off** when heated water is not needed.

Outside Faucet

An outside faucet is provided in the L.P.G. tank compartment so it is not necessary to enter coach to wash hands, etc.

The low point drain valve under the bathroom lavatory must be open to supply water to this faucet.

While traveling in freezing weather, this faucet should be left open and the low point drain valve closed.

Drainage System

A diagram of the drainage system is provided in Section X. Separate holding tanks for gray water (56 gallons) and waste (50 gallons - 40 gallons for 31 and 33 foot coaches) are located beneath the coach mid-section. The gray water holding tank is the receiver for the gray water from the kitchen sink and the shower. The waste holding tank stores toilet wastes and waste water from the bathroom lavatory. Each holding tank has a separate drain valve, dumping gray water and wastes through a common single discharge connection on the road (left) side. Separate vents from each holding tank extend through the roof of the coach.



Note

On optional rear bath coaches, the waste holding tank stores toilet wastes and receives water from the kitchen sink while the gray water holding tank is the receiver for the bathroom tub/shower and lavatory.

Draining the Holding Tanks

The waste holding tank is drained first, then the gray water tank. Drain the holding tanks as follows:

1. Check that both drain valves are in a closed position before removing drain cap. Note that the valve handles are turned clockwise to lock the valve.

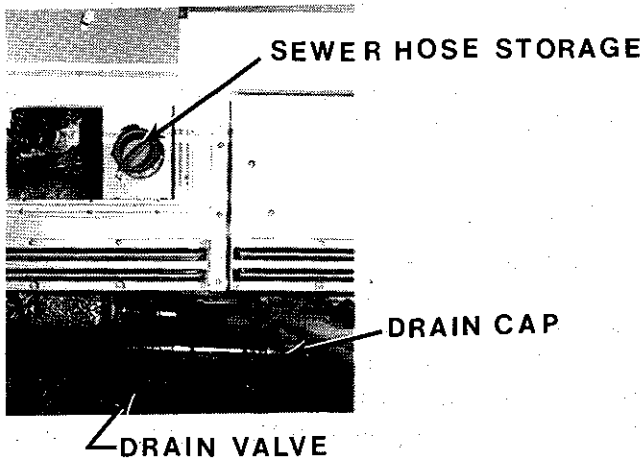

Figure 5-4. Location of Holding Tanks Drain Valve

2. Remove the safety cap from the single discharge connection by turning the locking ring in a counter-clockwise direction and connect the 3-inch sewer hose coupling to the end of the valve. Tighten locking ring securely, in a clockwise direction. The sewer hose is stored within a tube accessible through a compartment door located above the drain cap, figure 5-4. Place the discharge end of the hose into the sewer connection and check that all connections are secure to prevent accidental spillage.

3. Open the drain valves, by turning the handles to the left (counterclockwise) to unlock, then pull the handles straight outward.

4. After contents are emptied, flush out holding tank to dislodge remaining solids.

Note

To clean the holding tank, add a detergent solution into the tank after it is emptied. The agitating action from vehicle movement will clean the tank.

5. Close drain valves by pushing handle inward and turning to the right (clockwise) into the locked position.

6. Disconnect and wash out drain hose, replace hose and replace safety cap securely.

Tank Level Detectors

Each of the holding tanks and the potable water supply tank has a level detector which provides an electrical input to the Systems Monitor panel on the galley side wall. Activate the display to read the level of liquid remaining in each tank by pressing the appropriate pushbutton switch.

Winterizing

To prevent freezing of water supply lines, they are wrapped with heat tapes that operate automatically when the temperature drops below 38 degrees F. The heat tapes are connected to the ac outlets in the rear of the refrigerator compartment and behind the kitchen sink base.

If you are planning on storing your motorhome in an unheated area during cold weather, it will be necessary to winterize the water system to prevent damage from freezing conditions. Winterizing procedures are covered in the following paragraphs.

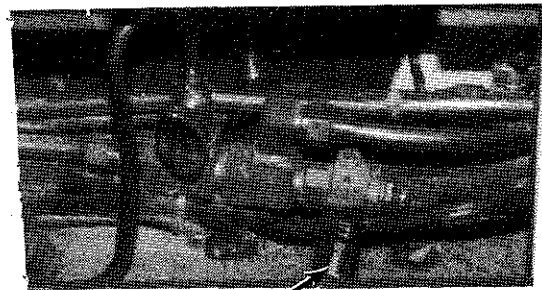

Figure 5-5. Lavatory Plumbing



Draining and Winterizing the Fresh Water Supply System

The following procedures show the use of the various drain valves, controls and pressurized air system to remove the water from the plumbing and appliances in the fresh water supply system. Refer to figures 5-2 through 5-5 for the location of controls and valves.

1. Open the main circuit breaker box, figure 4-4, and set the **Water Heater** and **Konstant Hot** switches to **Off**.

2. Set **Water Pump** switch to **On** and open all faucets (galley sink, lavatory, shower, outside hose connection and toilet water valve — after depressing pedal insert block to maintain position). Note that the outside water hose connection should always be left open when freezing temperatures are expected. Also, remove thumbscrew from bottom of toilet valve, and drain screw at bottom of **Konstant Hot**. If equipped with Ice-Maker refer to **Draining the Ice-Maker** below.

3. Open the low-point drain valve located beneath the lavatory, figure 5-5.

4. Turn the **Water Tank Drain** control to **Open** position, and the **Water Heater** switch to **Drain** position. Both controls are located on a panel in the bed base cabinet, figure 5-2.

5. Allow water to drain completely before proceeding to the next step.

6. Move the **Water Heater** switch to **Fill**.

7. Set **Water Purge Air Pressure** switch, figure 5-2, to **On** to activate the solenoid which applies air pressure to the input water line to purge the water system. Note that it may be necessary to start the engine to build up air pressure. An air hose must be connected momentarily to the valve fitting on top of the accumulator, figure 5-3, to be sure that no water remains.

8. When only air remains in the line, close both low-point drain valves and all faucets except the cold water galley sink faucet. This will ensure that the water purifier is cleared of residual water. Momentarily operate the **Konstant Hot** instant water heater valve to clear the heat exchanger of remaining water.

9. Turn **Water Purge Air Pressure** control to

Off, set **Water Pump** switch off, and shut down engine.

10. Disconnect both hoses from the water pump to prevent residual water from backing up into the pump.

11. Open all faucets slightly, open both lowpoint drain valves and toilet valve.

12. Drain the holding tanks and add RV anti-freeze (several quarts) to each tank through the toilet (into the sewage tank); and through the galley sink (gray water tank).

13. At this point, the only water remaining in the system is contained in the U-traps (P traps) beneath the lavatory and shower drain. To prevent this water from freezing and damaging the traps, pour one pint of RV system anti-freeze into each trap.

Draining the Ice-Maker — If your motorhome is equipped with an ice-maker it will also have to be drained so that no water remains in the line or ice-making mechanism.

1. Remove the cover from the bottom compartment and turn the switch **Off**.

2. Disconnect the water line from the solenoid valve fitting.

3. This line must be blown free of water, and can best be done while clearing the purifier in step 8 above. Do not reconnect the water line at this time.

4. Turn **On** the ice-maker and allow it to operate until all remaining water is drained (approximately one hour). Remove any water remaining in the ice-maker mold, drip tray, or cube compartment.

5. Turn ice-maker **Off**, reconnect water line, and leave door slightly ajar to prevent interior humidity build-up from corroding the ice-making mechanism micro-switches.

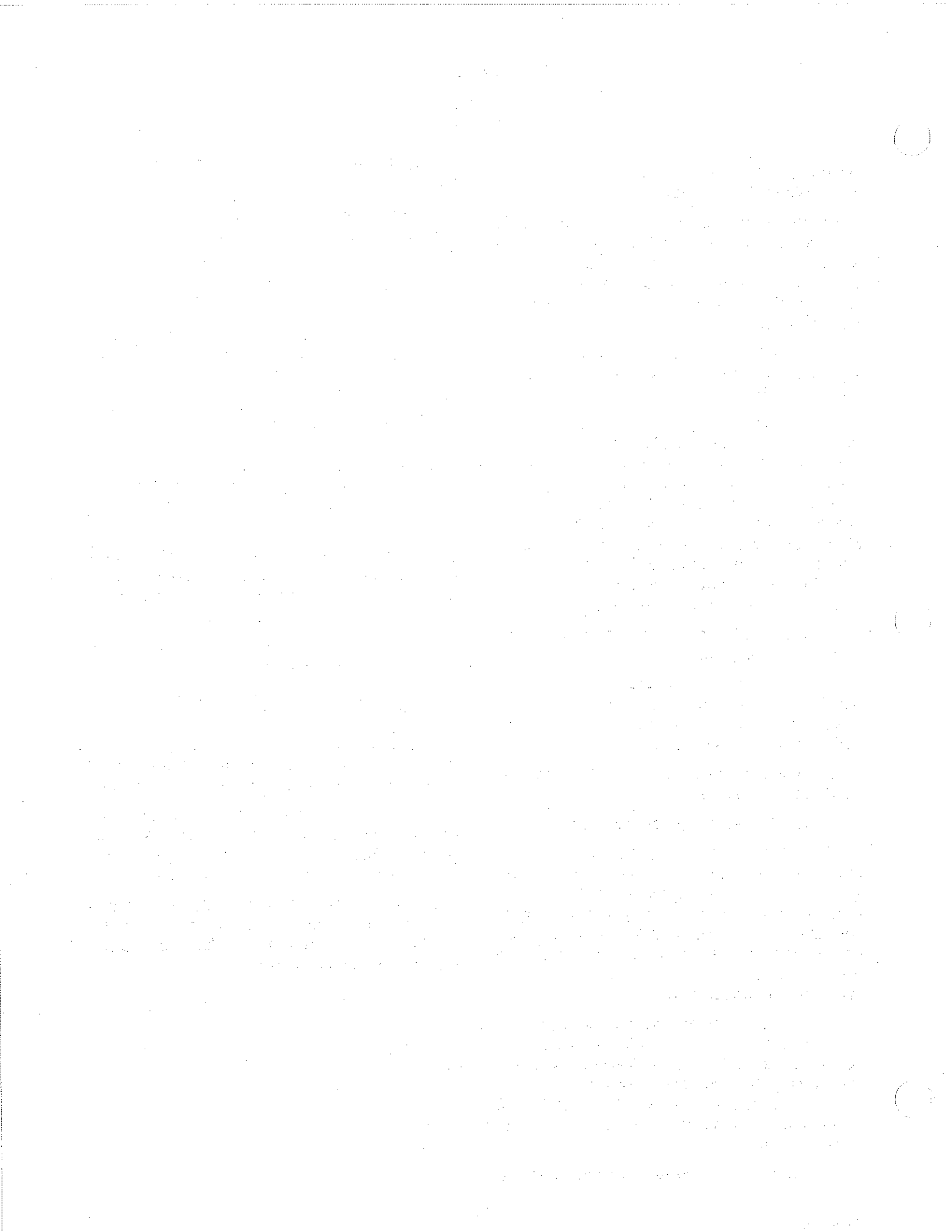



Section VI LPG System

The coach is equipped with a permanently mounted 43.5 gallon (148 pounds of fuel-net) LP gas tank which is the energy source for the range/oven, three gas furnaces and alternate source for the refrigerator. A piping diagram of the LPG system is shown in Section X.

LPG Tank and Controls

The LPG supply tank is located in a curbside compartment, as shown in figure 6-1. LPG system controls include a main gas service valve, high pressure regulator, filler connection with Auto Stop (80%) fill valve, 20% vapor (stop filling when liquid appears) valve, and the pressure relief valve.

A flexible hose from the high pressure regulator connects to tubing which carries the LP gas to the refrigerator vent compartment. Conveniently located in this compartment are the low pressure regulator (set at 11 inch water column), manual shut off valve, electrical solenoid shutoff valve, and manifold to individual appliance shutoff valves shown in figure 6-2.

The solenoid valve is actuated by either a high-pressure condition (caused by a defective regulator), or by the remote LP leak detector, located below the refrigerator door. Tank level can be monitored at the Systems Monitor panel on the galley wall. To read the digital display, press the **Propane Tank** button.

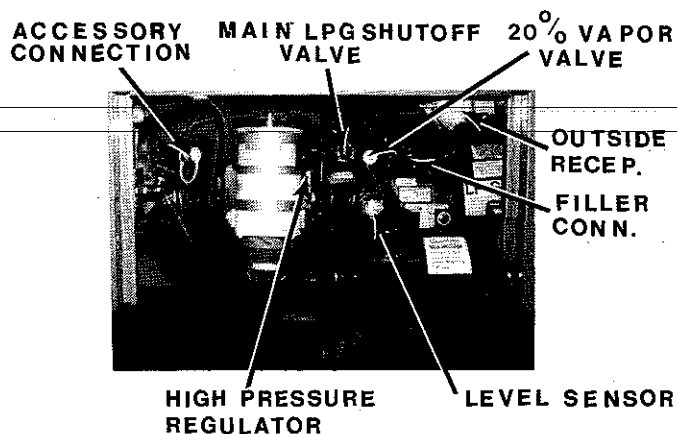

Figure 6-1. LPG Tank Compartment

Caution

Be sure to shut off all gas appliances before filling the LPG tank. Check gas lines and fittings periodically for tightness and leakage.

Fuel Requirements

Liquefied petroleum gas is a material composed of various hydrocarbons such as propane, butane, or a mixture thereof. In its gaseous form (vaporized) it is colorless and has a garlic-scented additive to ensure detection. In addition to being highly inflammable, it is also dangerous to inhale. For ease of transportation and storage, LPG is compressed into a liquid state and stored, in this form, within the LPG tank. As fuel is used, vapor passes from the top of the tank, via the high-pressure regulator, to the low-pressure regulator, and to the various gas appliances.

Appliances will not function if the LP gas does not vaporize. Butane will not vaporize below 32 degrees F. (the freezing point of water), but propane will continue to vaporize down to 44 degrees below zero. Propane has become the main type of LP gas used in RV's in recent years. Your LP supplier will have the correct type or blend for your locale. If your travels will take you into an area where climate differs, ask your LP dealer for his recommendations. The names of LP suppliers can be found in the yellow pages of your telephone directory under "Gas-Liquefied Petroleum - Bottled & Bulk".



Many campgrounds now have LP gas fill facilities, as do some service stations.

Prevent condensation and possible regulator or line freeze-ups, when filling the tank, by requesting the dealer to add a small amount of Methyl Alcohol to the fill-up. A common mixture is one ounce of Methyl Alcohol to each 20 pounds of LPG.

Filling the LP Gas Tank

When the tank is being filled, the Service valve must be **Closed** and the 80% liquid level valve (20% vapor valve) must be **Open**. The 80% **Auto** stop fill valve may close before liquid appears at the 80% liquid level valve, but if liquid does appear, stop filling immediately; the tank is filled to its LP capacity. Close the liquid level valve. Do not use a wrench to tighten this or the **Service** valve; they are designed to be closed leak-tight by hand. If you cannot hand-tighten properly, the valve probably needs repair or replacement.

LP Gas and Vapor Detectors

The Gas/Smoke alarm, on the galley wall, monitors various locations through the coach and sounds an alarm if the safe amount of LP gas or carbon monoxide in air is exceeded. The LP gas leakage detector below the refrigerator door monitors the area near the refrigerator and the range, sounding an alarm and actuating the LP gas solenoid shut-off valve if a leak is sensed.

Regulator Pressure

The low-pressure regulator, located in the refrigerator compartment, figure 6-2, regulates the pressure of the LPG supplied to the appliances. The regulator functions automatically and is factory-preset to provide the correct line pressure. **Do Not** attempt to tamper with or reset the regulator! Even a small variation above the normal gas line pressure can be sufficient to create a dangerous situation and cause possible damage to individual appliance components. If there is any doubt about the regulator setting it can be checked by your Wanderlodge® dealer or LPG supplier. The correct setting is 11 inch water column.

Operation

To operate any LPG appliance, the main gas (Service) valve, figure 6-1, must be **Open** as well as the individual appliance valve in the refrigerator vent compartment. The range also has a shutoff

valve behind the range top. When first used, or after a refill, there may be some air in the gas lines which will escape when you open a range burner or similar LP gas valve. The air may extinguish your match or igniter the first time or two, before you get ignition. Remember, too, that when you close the tank's Service Valve some of the gas will remain in the lines. To completely bleed the lines of gas, **Close** the tank's **Service** valve and light a range burner to use up the excess. When the flame burns out, turn the range burner **Off**.

Checking For Leaks

Periodically check the LPG system for possible leakage. Do not wait for an alarm condition to occur before correcting a leak! Although the entire system and associated appliances undergo extensive factory testing for leakage, road shocks and heavy vibrations may loosen or damage piping or fittings. Leaks will usually become noticeable by the characteristic odor of the garlic-scented gas additive. To check, turn off all burners and pilot lights. Open all doors and windows. Open LPG tank service valve and use an ammonia & chlorine free soap-bubble solution on all connections. Any bubbles are evidence of leakage.

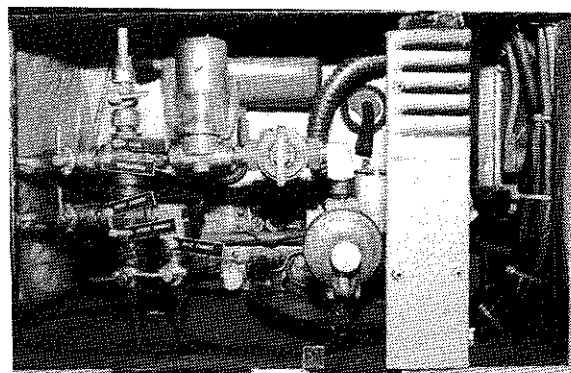

Figure 6-2. LPG Low-Pressure Distribution



Note

The gas leakage detectors may momentarily sound an alarm when the engine is initially started or when a heavy electrical load is placed on the system. Further, the ultrasensitive response of these units may also cause an alarm to be given in the presence of certain pressurized-can sprays or cleaning agents. **Do Not Assume! Always Determine the Reason For This Vital Alarm Being Given!**

LPG Consumption

Most gas appliances are intermittently operated. However, operation during cold weather conditions does cause a heavy use of the gas furnaces. Extensive oven usage also consumes a great deal of fuel. The amount of LPG consumption depends on the total use and manner of use of these appliances.

Note that each gallon (4-1/4) lbs of LPG fuel produces approximately 91,500 BTU's of heat energy. The LPG tank used in your coach will furnish over 3 million BTU's.

For your guidance in estimating your anticipated fuel consumption, the following is a listing of typical appliance consumption ratings when the appliance is operated for one hour:

Refrigerator	1,500 BTU's
Range Oven	10,000 BTU's
Range Top Burners	5,200 BTU's Each
Furnaces (3)	16,000 BTU's Each

LPG System Warnings

Warning

LP gas containers shall not be placed or stored inside the vehicle. LP gas containers are equipped with safety devices which relieve excessive pressure by discharging gas to the atmosphere.

Warning

It is not safe to use cooking appliances for comfort heating.

Cooking appliances need fresh air for safe operation. Before operation:

1. Open overhead vent or turn on exhaust fan.
2. Open Window.

This warning label has been located in the cooking area to remind you to provide an adequate supply of fresh air for combustion. Unlike homes, the amount of oxygen supply is limited due to the size of the recreational vehicle, and proper ventilation when using the cooking appliance(s) will avoid dangers of asphyxiation. It is especially important that cooking appliances not be used for comfort heating as the danger of asphyxiation is greater when the appliance is used for long periods of time.

A warning label has been located near the LP gas container. This label reads.

Do not fill container(s) to more than 80 percent of capacity.

Overfilling the LP gas container can result in uncontrolled gas flow which can cause fire or explosion. A properly filled container will contain approximately 80 percent of its volume as liquid LP gas.

Warning

Portable fuel-burning equipment, including wood and charcoal grills and stoves, shall not be used inside the recreational vehicle. The use of this equipment inside the recreational vehicle may cause fires or asphyxiation.

Warning

Do not bring or store LP gas containers, gasoline or other flammable liquids inside the vehicle because a fire or explosion may result.

The following label has been placed in the vehicle near the range area:

If You Smell Gas:

1. Extinguish any open flames, pilot lights and all smoking materials.
2. Do not touch electrical switches.
3. Shut off the gas supply at the tank valve(s) or gas supply connection.
4. Open doors and other ventilating openings.
5. Leave the area until odor clears
6. Have the gas system checked and leakage source corrected before using again.



LP gas regulators must always be installed with the diaphragm vent facing downward. This will minimize any chances of vent blockage which could result in excessive gas pressure causing fire or explosion.

Warning

Never check for leaks with an open flame. Do not check copper plumbing lines for leaks using ammoniated or chlorinated household-type detergents. These can cause cracks to form on the line and brass fittings. If the leak cannot be located, take the unit to your Wanderlodge® dealer or LPG supplier.



Section VII

Air Brake System

Your motorhome is equipped with dual service air brake systems for front and rear brakes, with integral fail/safe operation; and manual/automatic rear spring (parking) brakes. As shown in the air brakes system diagram in Section X, the service brakes are completely independent systems, each including a reservoir and separate distribution lines and valves. A separate reservoir is also supplied for the rear spring brakes, which function independently of the service brakes. All three reservoirs are pressurized from a single compressor. Both service brake systems are brought into operation each time the brake treadle is depressed to slow or stop the coach. Reservoir pressure for each service brake system is monitored by a respective pressure gauge on the front panel; system failure(s) are indicated by low pressure readings, illumination of the **Low Air** failure lamp, located above the Blue Bird Wanderlodge Logo in the center of the dash, and by sounding of the low air warning buzzer.

Operation

When the coach is parked, and the engine off, the rear spring brakes will normally be set by operating the parking brake. The spring brakes cannot be fully released until the air pressure is above 65 psi. These brakes are in the released position when the control is pushed in. In the event that there is a loss of air pressure, the spring brakes will set automatically, at the brake-applied position, and will not release until the air reserve has again built up to required value. Consequently, there will be a normal delay, after the coach is first started, before the compressor builds up sufficient pressure in the three reservoir tanks, before the brakes can be released and the coach driven. When the brake treadle is depressed, to slow or stop the coach, reservoir air is applied simultaneously to both front and rear service brakes to effect the braking action. The spring brakes are held in a released position by the air pressure supplied from the associated reservoir tank.

Caution

Do not attempt to drive the coach until system pressure is above 90 psi.

Brake Failures

To compensate for normal lining wear, each brake system is individually self-adjusting.

A combination of fail/safe features provide protection against brake system failures. Each service braking system, front and rear, has a backup capability in the event of partial or total system failures. If the front brakes fail, operating the brake treadle activates the rear service brakes normally providing sufficient braking action to effectively stop the coach. If a failure occurs in the rear, the front service brakes and rear spring brakes provide braking action. Under these conditions, the spring brakes do not lock in, as in a normal set position, but instead their application is "modulated" in the same manner as the service brakes, thereby providing a normal braking "feel".

In the unlikely event of a failure where both service braking systems are disabled, the rear spring brakes will apply automatically and bring the vehicle to a stop. As a safety factor, the coach should not be moved until brake failures (any type) are corrected.

Note

With the front brake system service reservoir fully charged, enough air pressure is available to provide four full releases of the rear spring brakes. This will allow the coach to be brought to a safe position until repairs can be accomplished.

Additional Air-Operated Equipment

Besides providing the compressed air supply for the coach braking systems, the compressor also provides the air supply for the entry step, side-slide mechanism on pilot's and co-pilot's seats, front air vents, steering wheel tilt mechanism and air suspension system (air bags) — all via separately-controlled solenoid switches operated from the dash, or at other locations throughout the coach. (This compressed air source is furnished from the front right side reservoir.) A compressed air outlet fitting, tire gauge, and spiral hose are contained in the center storage compartment on the left side of



the coach, convenient for blowing out the water system, inflating tires, and so on. A Schrader valve (air connection) is available at the rear of the front right side air tank to allow the air system to be pressurized from a "shop" source without the necessity of starting the engine.

Compressed Air System Air Dryer

The air dryer unit collects and removes moisture and contaminants from the compressor air output before the air reaches the reservoirs. This unit is different from a reservoir drain or an aftercooler in that it provides dry air for the brake system by eliminating the possible accumulation of condensate in the system reservoirs. Note that each reservoir also has a drain cock on the bottom for draining accumulated moisture. This assures a long maintenance-free life for air brake system components due to the removal of system contaminants.

The air dryer is located between the compressor discharge (output) line and the compressed air reservoirs. A safety valve mounted in the air dryer housing assembly protects against excessive pressure buildup. The desiccant cartridge and pleated paper oil filters are easily removable and replaceable as a complete serviceable unit. The desiccant "beads" which provide the drying action have a large capacity for absorption due to their combined surface area. In addition, an internal thermostatically-controlled heating element prevents freezeups on the purge drain valve when the unit is used during sub-freezing temperatures.

Purging of the dryer is automatic, exhausting combined oil and water residue to the atmosphere. At the same time that the contaminants are purged the reverse air flow across the desiccant material removes the accumulated moisture and reactivates the desiccant. Cartridge replacement should be accomplished at 12-month periods; sooner, if the cartridge has become contaminated.



86 FC

Section VIII Owner Maintenance Data

This section provides general information for use in performing scheduled services as well as preventive and routine maintenance on your Wanderlodge®.

Caution

Cooling fan operation is controlled electrically by a thermostat which senses engine coolant temperature. Any time the engine is running the fan may engage and start to run without warning. The engine must be shut off and the fan stopped before servicing.

Specifications and Data

Table 8-1

Engine and Chassis Specifications

Engine	
Caterpillar 3208T	250 HP
Transmission	Allison MT643 4 speed
Chassis GVWR	34,000 lb.
Front Axle	13,200 lb.
Rear Axle	23,000 lb.
Wheelbase	216.5 in. (35 ft.); 194 in. (33 ft.) 179 in. (31 ft.)
Air Brake System	
Front Axle	Self adjusting 16.5 in. × 5 in. brakes
Rear Axle	Self-adjusting 16.5 in. × 7 in. brakes
Air Reservoirs	Three Air Tanks 4,760 cu. in.
Retarder	Jacobs Drive Line
Wheels & Tires (6)	Aluminum rim, 11R22.5, 16 PR tubeless steel-belted radial
Tire Inflation	See information plate inside stepwell compartment door (figure 4-3)
Axle Ratio	4.88:1
Leveling Jacks (Hydraulic)	
Front (each)	20790 lb. rating
Rear (each)	10990 lb. rating

The 1986 Wanderlodge® Forward Control has a swing-out radiator (with fold down bumper) which facilitates engine accessory belt changes.

Caution

Do not swing out radiator with engine running. Fan could start unexpectedly and cause serious injury.

- Alternator Belt —
W/L P/N 0814038 — Gates 9600 (2)
- Water Pump Belt —
W/L P/N 2106771 — Gates 9490 (2)
- Power Steering Belt —
W/L P/N 0854034 — Gates 9370 (1)
- Air Conditioning Compressor Belt —
W/L P/N 1040005 — Gates 9700 (1)
- Fan Belt — W/L P/N 2106714 — Gates 9430 (1)

Table 8-2

Engine/Chassis Capacities

- Diesel Fuel Tank Capacity
 - 35 ft. side bath 265 gallons
 - 31 & 33 ft. side bath 235 gallons
 - 33 & 35 ft. rear bath 225 gallons
- Lube Oil System
 - Refill Volume with Filter Change . . 20 quarts
 - Crankcase Capacity Low Mark 12 quarts
High Mark 16 quarts
- Cooling System Capacity . 40 quarts (approx. 64 quarts with cockpit & living area heaters)
- Oil Specifications for Engine
 - API CD/SE, CD/SF, CC/SE, or CC/SF
 - 30 degrees to 100 degrees F SAE 40, SAE 30, SAE 15W-40, or 10W-30
 - Below 30 degrees F SAE 10W-30, 15W-40, 5W-20, or SAE 10W
- Frequency of Oil Change
 - Every 300 engine hours with —
CD/SE or CD/SF oil
 - Every 200 engine hours with —
CC/SE or CC/SF oil
- Frequency of Filter Change Every oil change
- Oil Filter W/L p/n 3743481, CAT 9N6007
- Power Steering
 - Specification Dextron II
 - Capacity 4 quarts
- Leveling Jacks
 - Specification Dextron II
 - Capacity 10 quarts
- Transmission



Specification Dexron, Dexron II
Capacity (less external circuits) .. 16 quarts

Table 8-3

Generator Capacities and Specifications

Electrical Rating 12.5KW at 120 Vac
7.5 k.w. in 31 & 33 ft. coaches
Fuel Supply
Diesel: Tee in engine supply line.
Gasoline: 7.5 k.w. has separate 30 gal. tank
located at right rear.
Coolant System Water-cooled
12.5k.w. 10 quarts; 7.5 k.w. 7.5 quarts
Crankcase Capacity 5 quarts w/ filter,
Oil Filter
12.5 k.w. W/L P/N 3759453 Motorcraft FL-1A
7.5 k.w. W/L P/N 2267417 WIX 51764
Oil Specifications for Generator
API CC/SE, CC/SF, CD/SC
CD/SE, or CD/SF
30 degrees to 100 degrees F . SAE 10W-30
0 degrees to 30 degrees F ... SAE 10W-30
Below 0 degrees F SAE 5W-20
Battery 12 volts, 90AH

Table 8-4

**Motorhome Capacities
and Specifications**

Potable Water Tanks 96 gallons
(100 gallons w/rear bath)
Holding Tank, Gray Water 56 gallons
(52 gallons w/rear bath)
Holding Tank, Waste 50 gallons
(40 gallons, 31 & 33 ft. side Bath;
56 gallons w/rear bath)
LPG Tank 148 lbs.-net (43.5 gallons)
Water Pump 3.5 GPM
Water Heater 10 gallons
Batteries .. Six 6-volt batteries, series-parallel
connected to supply 12v at 660 AH
Battery Chargers 75 amperes output each
Air Conditioners*
Automotive 18,000 BTU
Central (3) 14,000 BTU ea.
Roof (std. w/rear bath & 31 & 33 ft. side bath)
13,500 BTU ea.
Hot Water Circulating Heaters**
Living Area (3) 50,000 BTU ea.
Bathroom 15,000 BTU
Cockpit Area 90,000 BTU
Gas/Hot Air Heaters*

Living Area (3) 16,000 BTU ea.
Electric Heaters, 120 volt (4) . 1500 watts ea.
*NEMA Rating
**SBBMA Rating

Table 8-5

Maintenance Schedule Summary

Item

— Frequency

— Type of Service

and Specification

Transmission

- At 5,000 miles, thereafter at normal oil change intervals
 - Replace transmission filter (W/L P/N 0998542, AC25011900)
 - in cooler return line.
- At 25,000 miles, or 12 months, whichever occurs first
 - Replace transmission oil (Dexron or Dexron II)
 - Replace transmission internal filter (Kit DDA P/N 23019201)

See Section X Diagram, Lubrication Guide for service of other Engine/Chassis components

Batteries

- Every 500 miles to 1,000 miles
 - Replenish cells with distilled water to 3/8-inch above plates.
 - Coat Battery terminals with lubricant

Air Cleaner

- 10,000 to 15,000 miles
 - Replace when air cleaner indicator (if so equipped) shows red after high power run. Loss of power and black smoke also indicate need for change. W/L P/N 0819698, DYNACELL T-512 (FARR)



86 FC

Fuel Filters

- 10,000 to 15,000 miles
 - Replace as required
 - W/L P/N 2236677, CAT 1P-2299
Racor Filter and Water Separator
Change when vacuum (Racor)
gauge goes ito red
Element W/L P/N 2254035
(Racor 2040SM)
Gasket (large) W/L P/N
3747359 (2) (Racor 11007)
Gasket (T-handle) W/L P/N
3747342 (Racor 11350)

Air Brakes System

Reservoir Tanks

- Daily or depending on usage (not necessary with air dryer)
 - Drain each reservoir tank of moisture by opening petcock at bottom of tank.

Air Compressor Air Dryer

- 23,000 miles, or every 3 months, or every 900 hours. Refer to Bendix Air Dryer Manual.
 - Check/replace air dryer cartridge W/L P/N 2107753 (Bendix 287313)

Air Suspension System

- 1,000 miles to 3,000 miles, or every month
 - Check air springs for even inflation
 - Check for tightness of nuts, bolts, air connections
 - Check shock absorbers for oil leakage, worn bushings
 - No lubrication is required

Table 8-6
12-Volt Lighting Equipment,
and Fuses, Current Usage

Item	Specification (Qty)/Amperes
Automotive Lighting Marker/Clearance/ Identification, bulb # 1895	(16)/4.5
Stoptlights, bulb upper & lower # 1157	(4)/8.4
Parking Lights bulb # 1157 & # 194 (front inside)	w/tag (9)/4.5
Turn Signal Lights bulb # 1157	(2)/4.2
Cornering Lights, bulb # 1156	

Side Turn Lights, 2/side, 2 # 1895 bulbs/light	
Indicator Light W/L P/N 2271955	
Relay—rear lights, W/L P/N 1077718, located at upper front load center	.14A. ea.
Hazard Warning	(6)/12.6
Tag Light, bulb # 168	(1)/.35
Headlights and Taillights (with park & tag)	
G.E. Halogen Sealed beam units 1C1 & 2C1	
Hi-beam operation	(9)/13.7
Low-beam operation	(7)/8.0
Driving Lights, bulb W/L P/N 2126019	(2)/15.6
Ignition (solenoids)	7.0
Instrument Panel—Electroluminescent (inverters)	(3)/1.0
Instrument Panel—	
Gauges, bulb # 53	(14)/1.7
Spot Light, bulb W/L P/N 2103760	6.8
Stepwell outside, bulb # 53	(1)/.12
Stepwell inside, bulb # 67	(1)/.55
Landing Lights, bulb assy. W/L P/N 2261626	(4)/27.2
Backup Lights, bulb # 1156	(2)/3.8
Rear Parking Halogen	(2)/13.4
Engine Compartment Lights bulb # 1416	(1)/.8
Luggage & Stepwell Compartment Lights bulb # 1416	.8A. ea.
Porch light, bulb # F8T5/CW	(2)/2.2
Interior Lighting	
Reading Spots, bulb # 1383	(15)/1.54 ea.
Front Living, Flush, bulb# F15T8/CW	(8)/14.0
Aisle, Bulb # 53	(3)/.36
Bathroom Mirror bulb # F8T5/CW	(2)/2.2
Bathroom, Flush, bulb# F15T8/CW	(2)/3.5
Shower, bulb # 1141	(1)/1.5
Dinette, Flush, bulb # F15T8/CW	(2)/3.5
Kitchen, Flush, bulb# F15T8/CW	(2)/3.5
Bedroom Flush bulb # F15T8/CW	(4)/7
Ceiling, Flush, bulb # F15T8/CW	(2)/3.5
Vent Fans, bulb # 912 @1.0A.	(3)/4/Vent
Windshield Wipers	(2)/8.0(max.)
Water Pump	(1)/6.2
Blower Motors	
Front Heater (Hi/Lo) Right	(1)9.0/4.5
Defroster (Hi/Lo)	(1)/9.0/4.5
Foot Warmer (Hi/Lo) Left	(1)/9.0/4.5



Chassis Heater (Hi/Lo)	(3)/9.0/4.5 ea.
LPG Furnace	(3)/9.0
Portable Fan	(1)/1.0
Duct Booster	(1)/1.0
Ceiling Vent (Round)	(2)/8.0
Vent Fan (Square)	(3)/6.6
Stereo System	(1)/15
Motor Generator(Optional)	(1)/14.6

Fuses

Electronic equipment fuses are located in left front and left rear 12 volt load centers. Diagrams are inside covers.

Radio Privacy Switch — left front load center, # 72 orange/black wire, AGC3

AM/FM Stereo Tuner/Cassette Player — left front load center, # 3 green/white wire, AGC5

Radio Memory Circuit — left front load center, # 35 pink wire, AGC3

Refrigerator — left front load center, # 14 gray wire, AGC10

Spot Light Rotation — upper front load center (behind rubber flap), red wire, AGC3

Burglar Alarm — under dash right side below master switch, red wire, AGC2

Turn/Hazard Flasher — under dash left side of steering column behind retarder, black wire; fuse below master switch, AGC15

Changing Wheels/Tires

The wheel/tire assemblies used on your motorhome are heavy-duty truck-type. They are **heavy** and may be difficult to handle. If at all possible, changes should be accomplished by a service station equipped to handle truck equipment. However, if a situation arises where no service facilities are available, the following procedures may be used.

1. Drive motorhome out of traffic lane onto a level surface capable of supporting jack.
2. Turn on hazard flasher and apply parking brakes before leaving coach.
3. Turn off ignition and set transmission selector to **Neutral (N)** position.

4. Remove white plastic wheel saver, jack, lug wrench and handles from front curb side storage compartment.
5. Place wheel chocks against front & rear of tires on opposite side.
6. Place jack under axle and raise slightly until securely in place. See figure 8-1 for location of typical jacking point.

Caution

Bumpers are not designed for lifting and/or towing of the vehicle.

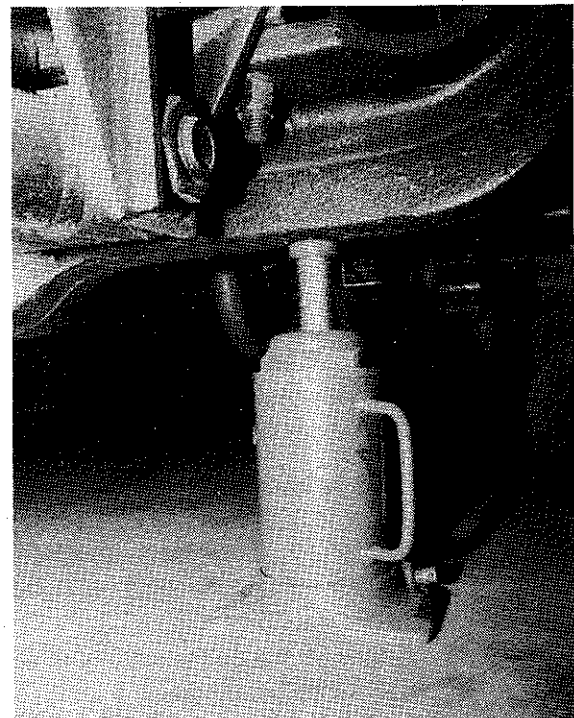

Figure 8-1. Locating Jack

7. Remove spare wheel assembly from mounting and place on ground near work area.
8. Pull off lug nut covers.
9. Install wheel saver.
10. Loosen lug nuts slightly, then jack up coach until tire is clear of ground. Solidly support the vehicle under the main frame rails with jackstands or blocks before working under or around the coach.



Note

Lug nuts on right side of coach are righthand threaded (turn counterclockwise to loosen, clockwise to tighten); lug nuts on driver's side of coach are lefthand threaded (turn clockwise to loosen, counterclockwise to tighten).

11. Remove lug nuts and wheel assembly.
12. Install spare and replace lug nuts. Tighten progressively in the sequence shown in figure 8-2 starting with # 1 and proceeding to # 10. Final torque will be 450 to 500 foot-pounds.

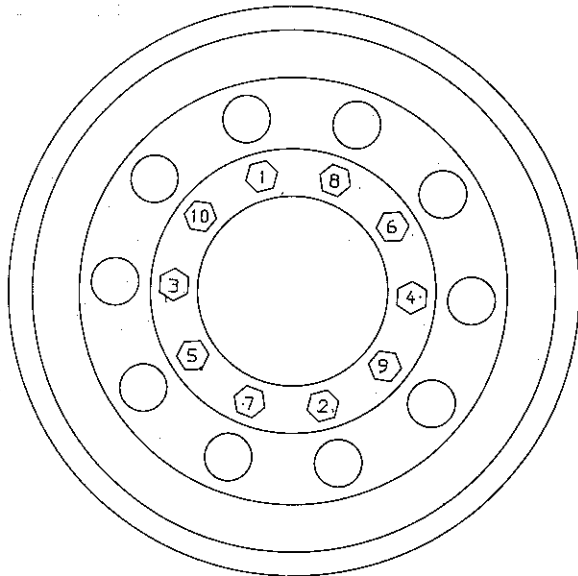

Figure 8-2. Lug Nut Tightening Pattern

13. Snap front hub cover into front wheel opening after front lug nuts have been properly torqued.
14. Install rear inside wheel assembly using inner lug nuts.
15. After rear outside wheel assembly is placed on the inner lug nuts, install outer lug nuts on lug numbers 5,6,7,8,9,10 and torque. Place rear hub cover over lug nuts and install lug nut lock rings (provided with rear hub cover) and lug nuts over lug numbers 1,2,3,4 and torque.

16. Place lug nut covers on all outer lug nuts, front and rear. Make certain that these nut covers fit snugly. This is accomplished by squeezing the dimpled sides together before installing.
17. Lower coach to ground and remove jack and handle.
18. Replace wheel saver, lug wrench, jack and handles in storage compartment and tie down to prevent road noise. Return damaged wheel/tire assembly to holder and have it repaired as soon as possible.
19. Remove and stow wheel chocks.
20. Turn off hazard flasher before returning to traffic.

Caution

Check lug nuts for tightness every 1,000 miles. Lug nuts should be torqued to 450 to 500 foot-pounds.

Using the Optional Mountz Power Wrench

The Mountz Power Wrench, figure 8-3, is a 12-times force multiplier which is designed for easy removal of wheel lug nuts. This tool is supplied as a kit which includes a 1/2-inch square ratchet drive with extension sleeve, a precalibrated ratchet torque wrench, and both hex and square wheel lug nut sockets.

To remove the lug nut, jack up the side of the coach where the defective tire is located, or use the leveling jacks. Select the appropriate lug nut socket, fit the tool over the wheel nut (after installing wheel saver), as shown, attach the 1/2-inch drive reaction bar and remove the nut(s). After the wheel is replaced, replace all nuts finger-tight, remove the reaction bar and use the precalibrated torque wrench to tighten the wheel nuts to the proper torque. Do not use the reaction bar to tighten the lug nuts. When tightening nuts, work opposite sides so that all nuts are equally torqued. Note that the torque wrench is factory calibrated to provide an inner cap nut and lug nut torque of 450 foot-pounds; an audible **click** indicates proper torque. For maximum accuracy, the torque wrench should be recalibrated on a yearly basis.

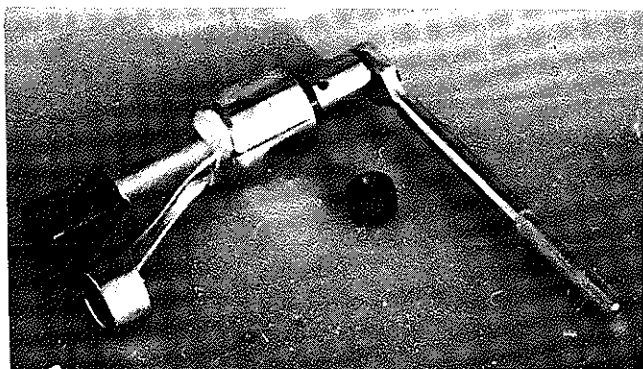

Figure 8-3. Mountz Power Wrench

Battery Maintenance

Your motorhome is equipped with six 6-volt batteries, connected in a series-parallel arrangement to provide 12 volts for engine and motorhome use. This arrangement makes available 660 AH (20 hour rate). Four batteries are located on a slide-out tray in the front compartment on the road side, as shown in figure 4-2 and two are on a similar tray in the curb side front compartment. A separate 12-volt battery is contained in the generator compartment and is used only for the generator. All batteries are charged from either the engine alternator or battery chargers (when 120 volts ac is available). Note that the generator will supply 120 volt ac to the battery chargers.

Periodic Battery Checks and Maintenance

Periodically check electrolyte level in the four six-volt batteries. The generator battery is sealed so it is not necessary to check the level of the electrolyte. Battery condition depends on battery usage and proper utilization of the battery chargers.

Caution

Do not wear metal rings, watches or jewelry when working on or near the batteries, cables, solenoids, or chassis wiring. These can short out electrical wiring and cause injury

To make sure that the batteries are always ready for use, periodically check and charge as necessary. Check batteries at least every two weeks in freezing weather; at least every four weeks in warmer weather. A fully-charged battery will not freeze under normal circumstances, so it is

imperative that the batteries remain charged during winter. A safe level of charge is a specific gravity reading of 1.225 to 1.280. Always use a battery hydrometer which has a temperature correction scale. It is advisable to have the coach shoreline connected to the 120 volt ac supply so that the batteries remain fully charged.

A dirty battery may eventually dissipate its charge through conductive surface contamination. Clean battery top surface with a damp cloth and dry thoroughly. Check that battery terminals and associated battery jumper terminals are tight and free of corrosion. To clean terminals, neutralize corrosive deposits with a solution of baking soda, rinse with clear water, and dry. Note that commercial type spray-on battery cleaners are available at automotive supply stores. Use as directed to keep the batteries clean. Spray-on cable and terminal protective coatings are also available, easy to use, and effective.

Exterior Care

Exterior paint finish life can be extended by periodic cleaning and waxing. This will preserve the paint and allow easier removal of dirt and road tars. Use touch-up paint for small areas to keep the coach finish in like-new condition.

Frequent washing of the coach is necessary to prevent corrosion in areas where heavy salt sprays are evident. A clear acrylic spray may be used, with care, to control corrosive effects of salt spray on metal surfaces.

Caution

Avoid spraying water through the refrigerator vent door.

Interior Care

The interior can be kept in good condition with the use of approved cleaning agents for vinyl walls and ceilings, plastic fixtures, stainless steel, formica and so on. Never use abrasive cleaning agents on interior of refrigerators, or on the lavatory, tub/shower, or toilet, as they can cause permanent scratches. Be sure that the cleaning agent will not damage the material. Note that some plastics are incompatible with certain cleaners. Read the directions on the container before using. For the most part, the cleaners and polishes that would normally be used in your home are equally well-suited for use in your motorhome.



Fluid Level Checks

Crankcase Oil Level

The crankcase oil dipstick is readily available inside the engine cover at the right front corner of the air cleaner.

The oil level must be checked only with the engine off. Maintain oil level at the proper fill line. If checking oil level immediately after engine has been operating, allow a few minutes for the oil to drain back into the crankcase before checking the oil level reading.

The best time to check the oil is before getting underway because the engine is cool and the reading will be most accurate.

Bulk Oil Fill

The bulk oil fill system provides a convenient means of replenishing the oil supply during an oil change and for adding oil between changes. There is no need to use valuable storage space for cans of oil, opener and funnel.

An oil storage tank (with approximate 20 quart capacity) is located in the L.P.G. compartment. When this is pressurized from the air supply, oil can flow through the nozzle (located in the engine compartment) into the engine oil fill. A meter is provided to measure quantity by means of quart and gallon pointers for each individual fill and a totalizer to show all oil added to date. This is a handy way to keep track of oil consumption, etc.

Operation

1. Run engine, if necessary, to build up on board air supply.
2. Shut down engine.

Caution

Do not run engine while bulk oil fill is in use.

3. Zero meter pointers.
4. Turn on dash switch (figure 2-2, item 31).
5. Turn on switch in engine compartment.
6. Bulk oil tank red light should now be on.
7. Push nozzle tab lock out of the way and depress lever enough to eject a few drops of oil onto wiping rag.
8. Remove oil fill cover.

9. Place nozzle in engine oil fill opening and depress nozzle lever until desired amount of oil is shown by meter pointers.
10. Replace nozzle in holder.
11. Turn off bulk oil switches.
12. Replace oil fill cap.
13. Check oil level.

Power Steering Reservoir Fluid Level

Regularly check fluid level in the power steering reservoir. Add Dexron II as necessary to maintain the correct dipstick reading, depending on fluid/engine temperature. (Note that the dipstick is attached to the T-handle plug on top of the reservoir). If the fluid is at normal operating temperature — about 150 degrees, and hot to touch — the dipstick should indicate **FULL** or just below. If engine is cool, fluid level should read about 1/2 way between the **ADD** and **FULL** marks.

Transmission Fluid Level

The transmission dipstick is located just inside the engine cover opening (at the right rear).

Importance of Proper Oil Level

Since the transmission oil cools, lubricates, and transmits power, it is important that the proper oil level be maintained at all times. If it is too low, the converter and clutches will not receive an adequate supply of oil. This can result in poor performance or transmission failure. If the level is too high, the oil will aerate, causing the transmission to overheat. Check the oil level at intervals specified in your vehicle service instructions, or more frequently, if operating conditions indicate.

Oil Check Procedure

Always clean around the end of the fill tube before removing the dipstick. Dirt or foreign matter must not be permitted to enter the oil system. It can cause valves to stick, cause undue wear of transmission parts, or clog passages. Check the oil level by one of the following procedures and report any abnormal oil level to your maintenance personnel. Check for abnormal oil level, milky appearance or any trace of coolant in the oil.



Hot Check

1. Operate the transmission in a drive range until operating temperature (160-200°F; 71-93°C) is reached.

Note

The oil must be hot to ensure an accurate check. The oil level rises as temperature increases.

2. Shift through all drive ranges to fill the clutches and oil passages.
3. Park the vehicle on a level spot, shift to neutral **N** and apply the parking brake. Let the engine run at idle speed.
4. Wipe the dipstick clean and check the oil level. The safe operating level is any level within the **Hot Run** band on the dipstick.
5. If not within this range, add or drain oil as necessary to bring the level to the middle of the **Hot Run** band.

Cold Check

1. A cold check may be made when the sump temperature is 60-120°F (15-40°C).
2. Run the engine for at least one minute to clear the oil system of air.
3. With the engine running at idle, wipe the dipstick clean and check the oil level. Any level within the **Cold Run** band is safe for operating the vehicle. If the level is at or below the bottom of the **Cold Run** band, add oil until it reaches the middle of the **Cold Run** band.
4. Operate the vehicle and make a hot oil check when operating temperature is reached (160-200°F; 71-93°C).

Racor Filter and Water Separator System

Filter/Separator Operation

The three stages of the Racor filter/separator, figure 8-4, work in series to progressively clean the diesel fuel. Because virtually all water and larger particles of solid contamination are removed in the primary and secondary stages, the effective life of the fine micron replaceable element is 2-3 times longer than standard filters.

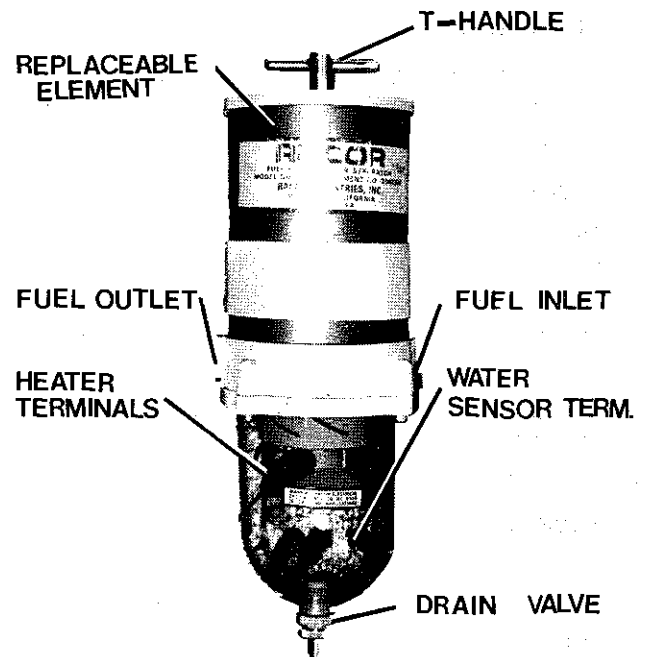

Figure 8-4. Racor Filter/Separator

Primary Stage (Separation) — In the primary stage, liquid and solid contamination down to 30 microns are separated out by centrifugal action created by the turbine centrifuge. There are no moving parts in this highly efficient design. Because the contamination is heavier than the fuel it falls to the bottom of the clear bowl.

Secondary Stage (Coalescing) — This stage functions when minute particles of liquid contaminants (lighter than the fuel) remain in suspension and flow up with the fuel into the lower part of the filter/separator shell. Here the minute particles tend to bead on the inner wall of the shell and the bottom of the replaceable cartridge. As the beads accumulate, they become larger and heavier and will eventually fall to the bottom of the filter/separator bowl.

Final Stage (Filtration) — In this stage the fuel enters the replaceable cartridge where the minute solids are removed.

In-Filter Fuel Heater

Internal automatic thermostats turn on the Racor in-filter fuel heater as the fuel temperature drops below 35°F. (1.7°C.)

The in-filter fuel heater operates from the 12-volt



battery source, supplying heat to the fuel filter just below the replaceable element. This critical placement provides increased fuel temperature as the fuel passes through the fine micron filtering element.

When the engine is not running and the temperature is below 35°F., the heater is operated by turning on the ignition switch for a maximum of 10 minutes prior to starting the engine. With the diesel fuel temperature above 35°F, there is no waxing or icing of the filter element. The in-filter heater is primarily a cold starting aid. Note that the top two terminals imbedded in the glass filter bowl connect to the internal heater.

Water-In-Filter Alarm

The electronic water sensor alerts the operator when liquid contaminants filtered out of the system should be drained from the collector bowl, thereby maintaining maximum filter/separator efficiency.

When water reaches a pre-determined level in the collector bowl, sensing probes activate the **Water-In-Filter** alarm circuit. The light illuminates, warning the operator to drain excessive water contamination collected in the bowl. Shut down engine before draining the bowl to avoid sucking air into the system. Note that the bottom two terminals imbedded in the bowl connect to the water sensors.

Maintenance

Filter Element — Routine maintenance of the Racor unit consists of periodic filter replacement and drainage of the moisture collected at the bottom of the bowl. (Engine is off during maintenance.)

Filter Element Replacement — Replace the element as follows:

1. Loosen handle and remove lid.
2. Inspect lid gaskets and replace, if necessary.
3. Remove filter element by grasping bale and lifting upward while rotating.
4. Replace Racor element by positioning over center return tube and twisting downward into place.
5. Top off by pouring clean diesel fuel into filter cylinder until full.
6. Replace lid and hand-tighten handle.

Draining — Drain bowl of accumulated moisture by opening petcock on bottom of bowl. Allow to flow until clean fuel appears.

Leveling Jacks Reservoir

The leveling jacks oil fill is located beneath the center entry step. Lift up the hinged step top (hinge at door side) and remove the screws attaching the square metal cover plate to gain access to the oil fill to check oil level.

Engine Cooling System Refill

Use of anti-freeze (ethylene glycol type only) is recommended for summer or winter operation because of it's corrosion inhibition and lubrication properties. A 50-50 solution of antifreeze and water is preferred and it gives freeze protection to about 30°F below zero. Ultimate protection is attained at 68% antifreeze (about 92°F below zero); a higher concentration of antifreeze should never be used. The approximate (dry) cooling system capacities are:

Engine, Radiator, & Engine Hoses	10 gallons
Right front heater system	2 gallons
Rear coach heater system	4 gallons
Total	16 gallons (64 quarts)

... so the system would require 8 gallons of anti-freeze for a 50% solution or 11 gallons for a 68% mixture. Final solution should always be tested with a thermo-hydrometer or equivalently reliable testing device to determine actual protection.

If it becomes necessary to completely re-fill the chassis coolant system, the following procedure must be followed (see figure 10-1). Pure antifreeze can be used initially until prescribed amount has been installed, and then water for final filling.

Engine, Radiator, and Engine Hoses

Locate and close the manual gate valves separating the engine from the heater systems. Both pressure and return valves for the coach heaters are under the pilot's floor. The pressure valve for the front (cockpit) heater is electric solenoid operated and the return line has a gate valve at the engine (lower right side front). Close the front heater electric solenoid valve by placing the **FRONT HEAT** switch in the pilot's control area to **OFF**. Remove the radiator cap and fill to the top.



Replace radiator cap and run engine @1500 to 2000 RPM for one minute to purge air from the engine water jacket. Shut off engine, carefully remove the radiator cap, re-fill the radiator, and replace the cap.

NOTE

Use extreme care at all times when removing the radiator cap as hot coolant under pressure can cause injury.

Front (Cockpit) Heater and Coach (Chassis) Rear Heater Systems

Air bleeder valves are located under the pilot's floor (at the return gate valve) for the coach system and over the radiator fill (in black tubing) for the front heater. Leave the return line gate valves closed and open the pressure line valves for front and coach heaters. Place the **FRONT HEAT** switch (item 26, figure 2-2) **ON** and the **HEAT SELECTOR** switch (item 25, figure 2-4) to **WINTER**. Press the **AUX. PUMP** switch (item 24, figure 2-4) **ON**.

Set area thermostats to the maximum high temperature position. Using suitable containers to catch coolant, open the bleeder valves and run the engine slightly over 2,000 RPM until a steady flow of coolant passes through the front heater bleed valve. Close bleed valve and open front heater return gate valve.

To ensure bleeding of the coach (chassis) heaters, the following additional operations should be performed.

1. Again run the engine slightly over 2,000 R.P.M. until steady flow comes from the bleeder valve under the pilot's floor.

Note

The radiator must be filled often during bleeding procedures.

2. Close bleeder valve and open return gate valve (under pilot's floor). Refill radiator using coolant recovered from bleeder valves and additional water as necessary.
3. Start and rev engine to maximum governed R.P.M. 2-3 times. Put **HEAT SELECTOR** switch to **SUMMER** and rev engine to max R.P.M. 3-4 times.
4. Return **HEAT SELECTOR** switch to **WINTER** and test heaters to make sure they are blowing

hot air.

5. Shut down engine and allow to cool.
6. Fill radiator completely.

Cooling System Additives

Automotive cooling systems are subject to various types of corrosion, rust, pitting and cavitation-erosion. These are common factors which prevent efficient cooling and contribute to engine overheating and higher maintenance costs resulting from replacement of hoses, fittings, filters and cracked heads. The manufacturer of the engine used in your motorhome recommends the use of Nalcool 2000 — a chemically buffered liquid additive which effectively neutralizes the formation of acids caused by dissolved exhaust gases, and inhibits the cooling system against corrosion and scale formation. This additive is compatible with most commercial automotive anti-freeze solutions containing ethylene glycol; however, its use is not recommended in cooling systems using Dow Therm 209. When refilling the coolant system, add four pints of Nalcool before topping off with anti-freeze solution. To ensure constant system protection, replenish Nalcool 2000 additive, periodically, in accordance with manufacturer's instructions.

Windshield Washers

Check reservoir fluid level periodically and use a prepared washer solution if possible. (Note that low reservoir levels are indicated by a dash monitor light.) During freezing weather, use a solution additive, or a solution specifically designed for cold weather usage. The washer reservoir is accessible through the front curb side storage compartment.

Battery Jumper Terminals and Jump-Starting

For your convenience and safety when jump-starting, terminal **posts** are provided at the top front and rear of the battery compartment, figure 4-2. Proper procedure for jump-starting is as follows:

1. Turn off all main battery-operated accessories in both vehicles — lights, radio, etc.
2. Connect one end of the positive-coded jumper cable to the positive (red) battery jumper terminal, and the opposite end of the cable to the positive (+) terminal on the other battery.
3. Connect one end of the negative-coded jumper



cable to the negative (–) terminal on the other battery and the opposite end of the cable to the negative (black) battery jumper terminal.

4. Once the engine of the disabled vehicle is started and brought up to idle, reverse the above procedure to remove the jumper cables. Always remove the jumper cable connected to the Wanderlodge® negative (black) battery jumper terminal first to prevent sparks at the other battery.

Caution

Avoid sparks in the vicinity of a charging battery: the gas produced is explosive.

Generator 12.5 k.w.

Keep the generator operating at peak efficiency by following a regular schedule for inspections and servicing, based on operating hours. Keep an accurate logbook record of maintenance, service and hours of operation, following regular schedules for normal operating conditions, and a more frequent service schedule for operation under dusty or dirty conditions. Check condition of crankcase oil and change air filter frequently until the proper service/time periods can be determined based on your usage.

After the first 15 to 30 hours of operation, arrange to have the following performed at an authorized service center.

- Drain and refill engine oil.
- Replace engine oil filter.
- Check external nuts and bolts for tightness.
- Torque cylinder head nuts.
- Check and adjust valve tappets.
- Check for fuel or lubricating oil leaks.
- Check radiator coolant level and inspect cooling system for leaks.
- Check and adjust water pump belt tension.
- Check mounting tray bolts and vibro mounts for tightness.
- Operate generator set at full or rated load, checking for proper output and governor operation.

Maintenance Schedules

Use the generator maintenance schedule in table 8-7 as a guide for routine and periodic maintenance. Neglecting generator maintenance

can result in failures or permanent generator damage. Refer to the generator service manual for detailed repair and maintenance.

**Table 8-7
Generator Maintenance Schedule**

Frequency

— Service

Daily, or before each startup

- Check oil level
- Check coolant level
- Clean radiator intake screen

Every 100 hours, or 6 months, whichever occurs first

- Change lubrication oil
- Change oil filter
- Service air cleaner
- Check engine for oil, water, or fuel leakage
- Check belt tension

Every 200 hours, or 12 months, whichever occurs first

- Check hoses and clamps
- Check and tighten electrical connections
- Check exhaust system for leakage
- Check and tighten mounting bolts
- Check generator brushes, commutator and slip rings
- Replace fuel filter element
- Check electrical system for frayed wires, corroded connections

Every 400 hours or 12 months

- Contact authorized service center for tuneup to include:
 - Injector inspection
 - Check and adjust valve tappets
 - Clean sliprings and inspect brushes
 - Check governor operation and adjust as necessary.

Periodically, perform a complete visual inspection of the generator when operating at full load.



Caution

The generator tray is air operated and extends outward with considerable force. To extend the tray, figure 8-5, unlock the hand-latch, located underside, by moving forward and then operate the Out-In switch in the stepwell compartment. Be sure that there is sufficient clearance in front of the tray and that nobody is in the way! Use extreme caution when observing an operating generator with tray extended.

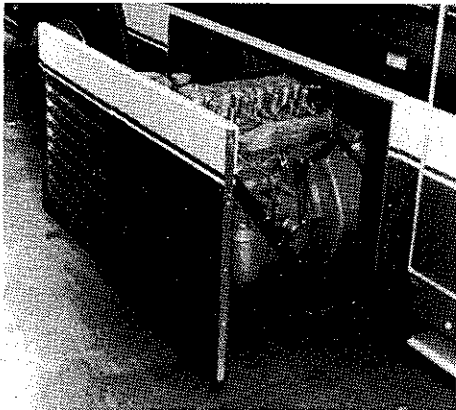

Figure 8-5. Generator Unit, Tray Extended

Battery

Check the condition of the generator battery periodically. See that battery connections are clean and secure. A light coating of nonconductive grease will prevent corrosion at terminals. Refer to Battery Maintenance procedures provided earlier in this section.

Air Cleaner

Proper maintenance of the air cleaner, figure 8-6, is extremely important. Allowing this vital element to become clogged with dirt restricts the flow of intake air into the engine. Operating with an over-rich fuel mixture caused by a poorly serviced or clogged air cleaner leads to formation of harmful carbon/sludge deposits.

This air cleaner should be serviced every 100 hours or six months as follows:

1. Loosen thumbscrew in Marman clamp while holding bowl.
2. Remove bowl.
3. Remove element thumbscrew and element.
4. Wash bowl in non-flammable cleaner. Allow to air dry.
5. Install new element and replace thumbscrew.
6. Replace bowl and tighten Marman clamp thumbscrew. Be sure letters **TOP** are up.

If operating under extremely dusty conditions, use dry compressed air to blow out generator at frequent intervals. Do this with the generator set operating and direct the stream of compressed air in through the cooling louvres at the end of the generator.

Oil Pressure

Always ensure that with the engine running, oil pressure is registering on the upper dash generator oil pressure gauge.

Pressures do vary according to climatic conditions and even between individual engines, but the oil pressure range at normal working speed and temperature will usually vary between 30 to 60 psi. The pressure will drop while the engine is idling and also a slight drop will be experienced when the oil is hot.

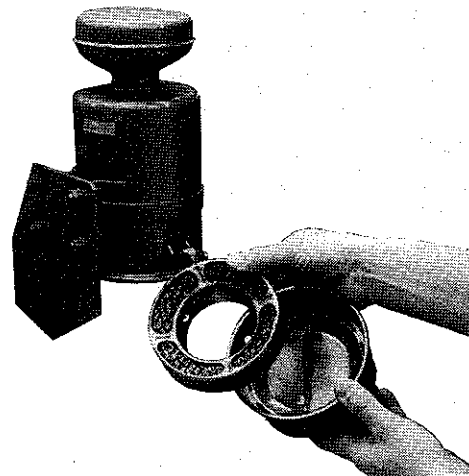

Figure 8-6. Generator Air Cleaner



Oil Filters

To ensure cleanliness of the lubricating oil, a sump strainer and a main full flow type of oil filter are used. The sump strainer consists of a gauze wire container which is fitted over the end of the lubricating oil pump suction pipe. All oil must pass through this strainer before it reaches the oil pump.

The main full flow type oil filter is mounted externally on the side of the cylinder block. All the oil passes through this filter after it leaves the pump, but before it reaches the bearings.

The full flow filter is a spinon cartridge in which the element is an integral part. Filter should be replaced at each oil change.

Replacing Oil Filter Cartridge

1. Unscrew the cartridge from the filter head.
2. Check that the threaded adapter is secure in the filter head and discard the old cartridge. Clean the filter head.
3. Using clean engine lubricating oil, lightly oil the top seal of the new cartridge. Prime filter by filling with new oil to bottom of threaded hole.
4. Screw the new cartridge on to the filter head until the seal just touches the head and then tighten by hand a further half of a turn. If the cartridge is overtightened, it may be difficult to remove later on.
5. Since the filter cartridge will normally be changed at the same time as the engine lubricating oil, refill the sump with oil, run the engine and check for oil leaks. Recheck the oil level after running the engine and add oil as necessary.

By-Pass Valve

If the lubricating oil filter element becomes contaminated to the extent where the lubricating oil has difficulty in passing through the element, a pressure difference will build up between the inlet and outlet sides of the filter assembly. When this pressure exceeds 50 psi (approximately), a ball valve opens in the filter headcasting and allows unfiltered oil to by-pass the filter element to protect the engine from oil starvation.

Oil Check

To be on the safe side, check oil in engine crankcase daily, or before each start, to ensure that the level is in the safe range between the **L** and **F** marks on the dipstick. Do not operate generator if level exceeds **F** mark, or is below **L** mark.

Caution

Do not check oil level while engine is operating. Engine must be stopped to obtain a true reading, as well as for safety reasons!

Oil Change

On a new engine, change the oil after the first five hours of operation and, thereafter, at 100 hour intervals, or every six months, whichever occurs first. Whenever possible, drain the oil while the engine is still warm. To drain, place a container below the unit, open the oil drain and allow sufficient time for the old oil to drain completely. After draining, close drain plug and tighten securely.

Cooling System

To avoid having the inconvenience of the generator shutting down due to overheating, or becoming damaged as a result of an overheat condition, be sure to keep the cooling air inlets to the compartment clean and unobstructed at all times.

Cooling system capacity is about 10 quarts of liquid (12.5 k.w.). When operating in climates subject to freezing temperatures, make sure that enough antifreeze solution is added to the coolant to prevent system freeze-up. (A drain petcock is provided on the underside of the radiator.) When draining the coolant, remove the radiator cap and open the block drain valve near the oil filler cap to prevent air pockets from forming and blocking water in passages in the block.

Check coolant level frequently and add anti-freeze mixture as needed to maintain correct level.

Table 8-8
Anti-Freeze Protection Chart

Anti-Freeze Protects to:	Mixture Proportions (ethylene glycol)
+ 16 degrees F (- 9 degrees C) 20%
+ 3 degrees F (- 16 degrees C) 30%
- 11 degrees F (- 24 degrees C) 40%



– 31 degrees F (– 35 degrees C) 50%

Generator Troubleshooting

Refer to the generator service manual for repair and maintenance data. Generator repairs should be accomplished by a qualified repair agency.

Generator Overloads

If the rated capacity of the generator is exceeded, the safeguard circuit breaker, located in box on rear wall of generator compartment, will trip to protect the generator against damage. This condition could be caused by a short in the coach ac supply circuits, or by operating too many appliances simultaneously, resulting in an overload condition. If the safeguard circuit breaker trips, the generator will continue running but no ac output will be supplied. Before resetting the circuit breakers, turn off some of the coach appliances and lighting to reduce the load to within the operating limits of the generator. If this is done, and the generator breakers still trip, a short circuit is indicated. Turn off the generator, locate and correct the cause of the short circuit.

Generator Battery Charging

Generator battery charging current is supplied through the isolator from either the engine alternator or the battery chargers (when ac power is available).

Storage Procedures

If the generator is to be out of service for a long period of time, perform the following procedures before placing the unit in storage:

1. Drain oil from crankcase (while hot) then flush with clean lightweight oil. Refill crankcase with regular-weight oil after flushing.
2. Clean exterior surfaces of generator set then spread a light film of oil over any unpainted metallic surfaces which could corrode.

Refrigerator

To ensure that your refrigerator will provide trouble-free operation, the following routine maintenance procedures should be performed at least once each year.

1. Inspect all gas connections for leakage, using a solution of soapy water. Tighten, as necessary.

2. Remove and clean the gas burner jet, figure as follows:

- a. Remove burner housing cover screw and cover (removal of drip cup will provide better access to screw).
- b. Unplug 120 volt ac cord.
- c. With refrigerator **on**, observe the burner flame. It should be clear blue over the slots of the burner, encircling the feeler point of the thermostat. If flame is otherwise, proceed as follows:
- d. Shut-off LPG supply and disconnect 12 volt dc leads.
- e. Disconnect lighter cable from electrode.
- f. Remove burner attachment screw and withdraw burner.
- g. Clean burner tube with brush and blow out with air nozzle.
- h. Unscrew burner jet, clean with alcohol and blow out with air nozzle. Inspect jet against light to see that it is clean.

Note

Do not clean jet with pin or sharp object. This will affect the size of the opening.

- i. Reassemble burner jet and replace burner being careful that end of burner fits into slot on bracket with slots of burner centrally located under the boiler tube. Reconnect 12 volt dc leads. Turn LPG supply and refrigerator **on**. Leak test burner jet seat.
- j. Observe burner flame. It should be as described in item 4. If not, take it to an authorized service center for proper adjustment.
- k. Replace burner housing cover and plug in 120 volt ac cord.



Air Conditioning Systems

Central conditioning units require periodic cleaning of the air filters. This is the only user maintenance recommended for these units. Under normal operating conditions, filters should be cleaned at least once each month. More frequent cleaning may be necessary in dusty areas.

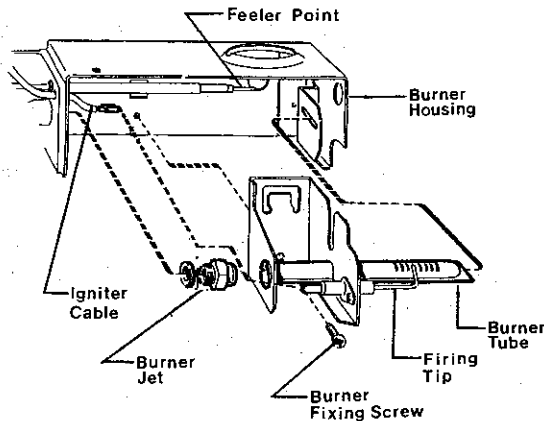

Figure 8-7. Refrigerator Gas Burner

The Electrode

For proper ignition it is necessary to keep the electrode insulation dry and free from dirt. The gap between burner tube and electrode shall be maximum $3/16$ " (5 mm) and minimum $1/8$ " (3 mm).

General

It is important to keep the refrigerator vent area clear and free from combustible materials, gasoline and other flammable vapors and liquids. Check the venting system. The flow of combustion and ventilating air must not be obstructed.

Check that the flue baffle is clean and reasonably free from soot. Heavy soot formation indicates improper functioning of the burner. Clean baffle and flue, cooling unit, and floor under refrigerator.

Check the energy selector system by connecting/disconnecting main voltage, start/stop the engine etc.

Compare and check that the system operates as described in Section III. If in doubt please contact a service center.

1. Turn unit off.
2. The filters (10" x 10") used for the central air conditioning evaporators are located behind aluminum air return grills in the living room and galley areas. In the bedroom, the filter is dropped into a slot on the inlet of the evaporator which is located at the rear of the bedroom over the engine compartment. It is accessible through the curb side closet at the rear of the bed. The filters behind the air return grills are accessible after rotating plastic tabs and pulling outward on grill top.
3. Wash filters in hot soapy water. **Do not use solvents in an alkali solution or allow to soak.**
4. Rinse filters with fresh water and air dry.
5. Replace filters.

Caution

Do not cycle compressor on and off rapidly or compressor damage may result. Once the compressor has been turned off, wait several minutes for system pressure to equalize before restarting unit.

To avoid damaging the air conditioning unit:

1. **Do not** turn the air control knob from a cool position to **Off** and then immediately back to a cool position.
2. **Do not** turn air control knob from any **Cool** position to a **Fan Only** position and then back to **Cool**.
3. **Do not** turn temperature control from a colder setting to a warmer setting and then back again rapidly.

Periodically check for proper drainage in the condensing unit (central air conditioning system) drip tray by rapidly pouring two quarts of water directly into the tray. The water should drain com-



pletely within 30 seconds. If not, clean tray and check drain holes for obstructions.

Toilet

No routine maintenance is required. If the bowl sealing blade fails to operate freely or does not close completely, clean foreign material out of sealing groove with stiff bristle brush.

To clean the toilet, use a high-grade, non-abrasive cleaner. Do not use highly concentrated or high-acid household cleaners. They may damage seals and finish.

Water Pump

Under normal usage, the water pump should require no periodic maintenance other than ensuring that the input water supply is properly filtered of particles that could damage the pump mechanism. Pump failures can generally be tied in to the plumbing system, or to electrical wiring. If the pump fails to operate properly, refer to the general trouble-shooting guide given in table 8-9. Note that detail pump repairs and overhaul should be performed by a qualified repair facility.

A pumpguard filter is provided on the suction side of the water pump. This should be cleaned periodically.

Table 8-9
Water Pump Troubleshooting Guide

Symptom

— Possible Cause

— Corrective Action

Pump operates but no water flows through faucet.

- Low water level in tank.
 - Add water.
- Suction lines or filter clogged.
 - Clear water lines and clean filter.
- Kink in water suction hose.
 - Check water hose connections to tank and straighten or replace, as necessary.
- Air leak in suction line.
 - Replace suction line.

Pump cycles on and off when faucets are closed.

- Water leak in plumbing.
 - Check for signs of leakage and tighten or replace fittings, pipe, etc.
- Defective toilet flush valve.
 - Repair flush valve.

Pump operates roughly and has excessive noise and vibration.

- Intake line is restricted, kink in suction hose or fittings too small.
 - Check input hoses and straighten or replace, as necessary.
- Loosened screws at pulleys and connecting rod.
 - Tighten screws.
- Deformed or collapsed pulsation dampener in pump.
 - Replace dampener.

Pump fails to start when faucet is opened.

- Clogged pressure piping.
 - Blow out water lines with compressed air.
- No voltage to pump.
 - Check input wiring, circuit breaker and switches.

Pump fails to stop when faucets are closed.

- Empty water tank.
 - Add water.
- Insufficient voltage to pump motor.
 - Check battery voltage. If voltage is OK, pump is defective.

Clock/Thermometer Calibration Procedures

The thermometer section of the Clock/Thermometer indicates either the inside temperature or outside temperature, depending on the position of the panel pushbutton. It may be necessary to recalibrate the unit if there are differences between the actual inside or outside temperatures and the corresponding displays.

Thermometer Calibration Procedures

1. Place an accurately calibrated thermometer unit next to the outdoor temperature probe (located under metal shield on outside of lower roof rail near refrigerator vent) while the coach is in a protected environment away from direct sunlight, rain, winds, etc. Note the thermometer



reading.

2. Press in the outdoor panel switch and compare the digital display reading with the actual outside temperature noted previously. If the reading disagrees sufficiently to require calibration, open the monitor panel so that the rear of the thermometer unit is accessible. (If the readings agree, proceed to step 3.) Adjust the outdoor calibration control, located in the extreme left center of the rear panel, as necessary, to make the display agree with the thermometer reading.
3. Place the calibrated thermometer unit next to the indoor temperature probe and note the thermometer reading.
4. Press the **Indoor** panel switch and compare the digital display reading with the actual inside temperature noted previously. If the readings disagree sufficiently to require calibration, open the monitor panel so that the rear of the thermometer unit is accessible. Adjust the indoor calibration control, located on the lower left-hand side of the rear panel, as necessary, to make the display agree with the thermometer reading. Replace the monitor panel.

Motor Generator (Redi-Line)

The optional motor generator is designed for unattended operation. Unlike a dc-to-ac inverter, which electronically changes the dc battery voltage to an ac line voltage, the motor generator includes a dc motor which generates an ac output in the same manner as commercial electricity is produced. Because of this, the ac output is completely isolated from the dc source. The stabilized ac output is used to operate the optional ice-maker. An 18 Amp. resettable circuit breaker (white button) is located next to the 120 volt AC receptacle on the unit panel.

User maintenance of this equipment is not recommended.

Tub/Shower Mixing Valve

The water mixing valve used in the tub/shower contains a pressure balancing spool valve, figure 8-8, to make sure there are no sudden temperature changes. Water mineral deposits which can accumulate in the valve body and spool valve will affect the normal operation of the mixing unit. To gain access to the valve body, remove the screws

which hold the faceplate to the shower wall. (Water supply must be turned off.) Remove the control knob, then lift off the faceplate.

To remove the spool, unscrew the large center screw and carefully withdraw the spool from the valve body. Inspect O-rings for damage and replace, if necessary. Flush out spool of any foreign material, then replace in valve. Replace faceplate and secure with screws. Replace knob.

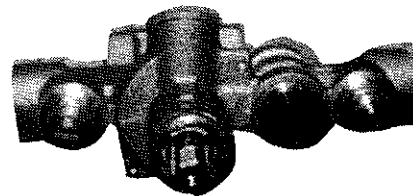

Figure 8-8. Tub/Shower Mixing Valve



Section IX

General Information

Equipment Manufacturers

Equipment

Manufacturer

Model or Type Number

Air Conditioner (Automotive)

Motive Manufacturing Division
3657 10th Avenue, North
Birmingham, AL 35234
Motivair

Awning

Zip-Dee Incorporated
96 Crossen Avenue
Elk Grove, IL 60007
Model BB (specify length)

Bath Vent

Hammond Manufacturing Corp.
P.O. Box 5393
2220 Raymond Drive
Lansing, MI 48905
Model CB-350-B Compact Blower

Burglar Alarm

Kolin Industries, Inc.
Box 357
Bronxville, NY 10708
Cat. No. 120

CB Radio

Audiovox Corporation
150 Marcus Blvd
Hauppauge, NY 11787
MDU-6000A

Central Air Conditioner

Marine Development Corporation
P.O. Box 8570
Richmond, VA 23226
Cruisair Model ACA 14U

Central Vacuum

Central Vac International
3133 East 12th Street
Los Angeles, CA 90023
Model 612 Floor-Recessed

Chime

General Electric Co.
Providence, RI 02940
CE 861

Closed Circuit TV Camera

RCA Corporation
Electronic Components Div.
New Holland Avenue
Lancaster, PA 17604
Monitor Model TC 2055 Camera

Closed Circuit TV Receiver

Audiotronics Co.
7428 Bellair Avenue
P.O. Box 3997
North Hollywood, CA 91609
900938-XX

Digitell System

P.M.M.I. Inc.
Drawer 10
Old Ocean, TX 77463
Digitell

Duct Booster

A and E Systems
3100 Segerstrom
Santa Ana, CA 92704
Mobile Heat

Electric Heaters

FASCO Industries, Inc.
810 Gillespie Street
Fayetteville, NC 28306
Model 2450
Living room, galley & bedroom

Markel Products Co.

726-740 Young
Tonawanda, NY 14150
Model No. E 3125 TE-RP Bathroom

TPI Corporation

P.O. Box T-CRS
Johnson City, TN 37601
Model BCIA05
Freeze Protection

Electric Heat Tapes

Easy Heat, Inc.
31977 U.S. 20 East
New Carlisle, IN 46552
MT Cables



Fan, Exhaust

Jensen Mfg. Co.
Los Angeles, CA 90040
262

Fan, Portable

Guest Corporation
17 Culbro Drive
West Hartford, CT 06110
12-volt Oscillating

Fan, Roof

Kool-O-Matic
1831 Terrace Road
Niles MI 49120
RU-12

Faucets

Stanadyne Moen Division
377 Woodland Avenue
Elyria, OH 44036

Flourescent Lights

Lighting Specialists, Inc.
P.O. Box 610
Marble Springs, TX 78654
NP-IT5-8
Bath Mirror
F-15R
Flush Mount

REC Specialities, Inc.
530 Constitution Avenue
Camarillo, CA 93010
Porch Light

Food Center

Scovill Industries
NuTone Division
Madison and Red Bank Roads
Cincinnati, OH 45277
Power Unit, Model 251
Food Processor Model 256

Fuel Filter - Water Separator

Racor Industries, Inc.
1137 Barium Road
Modesto, CA 95351
Model 1000FG
Detroit Diesel Engine
Model 500 FG
Kohler Power Generator

Furnace

Suburban Manufacturing Co.
P.O. Box 399
Dayton, OH 37321
Dyna-Trail Model NT-16SW

Gas/Smoke Alarm

P.M.M.I., Inc.
Drawer 10
Old Ocean, TX 77463

Ice Maker

U-Line Corporation
8900 North 55th Street
Milwaukee, WI 53223
Model BI-45A

Instant Hot Water

Emerson Electric Co.
4700 21st Street
Racine, WI 53406
STEAMIN' Hot
E-340-4

Intercom System

Newport Engineering
P.O. Box 1306
Newport Beach, CA 92663
Model TP-6S NEW MAR

LPG Alarm/Control

P.M.M.I., Inc.
Drawer 10
Old Ocean, TX 77463

LP Gas Grill

W.C. Bradley Enterprises, Inc.
P.O. Box 12040
Columbus, GA 31993
Charbroil
Model TG110

LPG Tank

Manchester Tank & Equipment Co.
2738 Lithonia Industrial Blvd.
Lithonia, GA 30058
No. 6042

Leveling Jacks

HWH Corporation
R.R. 1
Moscow, IA 52760
AP3179



Microwave/Convection Oven
Sharp Electronics Corp.
P.O. Box 588
Paramus, NJ 07652
Carousel R8340

Shower Hose Kit
Alsons Corporation
42 Union Street
Hillsdale, MI 49242
500 PB59

Motor Generator

Pacific Scientific Motor
and Control Division
P.O. Box 106
4301 Kishwaukee St.
Rockford, IL 61105
Model DA 14-L

Shower Valve

Stanadyne Moen Division
377 Woodland Avenue
Elyria, OH 44036

Mountz Power Wrench

Mountz, Inc.
1080 North 11th Street
San Jose, CA 95112
MP2

Tank, Water

Inca Plastics, Inc.
11555 Packard Drive
Middlebury, IN 46540

TV Antenna

Tandy Distributor Products
Swannanoa, NC 28788
Model 5MS550

Power Generator

Kohler Company
Kohler, WI 53044
12.5 KW

Toilet

Thetford Corporation
P.O. Box 1285
Ann Arbor, MI 48106
Aqua Magic Galaxy Model 08445

Radio (AM/FM Stereo Cassette)

Robert Bosch Sales Corp.
2800 South 25th Avenue
Broadview, IL 60153
Blaupunkt Tucson

Washer/Dryer

Sears Roebuck and Co.
675 Ponce De Leon Ave., N.E.
Atlanta, GA 30308
Washer: 26K4090
Dryer: 26K8090

Range and Oven

Magic Chef, Inc.
P.O. Box 1145
Elkhart, IN 46514
Model BRT 743S-5T

Water Heater

Mor-Flo Industries, Inc.
18450 S. Miles Road
Cleveland, OH 44128
Marine 10

Reading Lights

Wemac
3433 West Harvard
Santa Ana, CA 92904
Model 5019

Water Pump

ITT JABSCO
1485 Daleway
Costa Mesa, CA 92626
Model 36950-1180

Refrigerator

Dometic
P.O. Box 490
Elkhart, IN 46515
RM 1303

Water Purifier

Pure Water Enterprises, Inc.
343 Broad Street
Lake Charles, LA 70607
Model 7550

Safeline Warning Device

Omnifac Corporation
1700 East Whipp Road
Dayton, OH 45440
Model 2

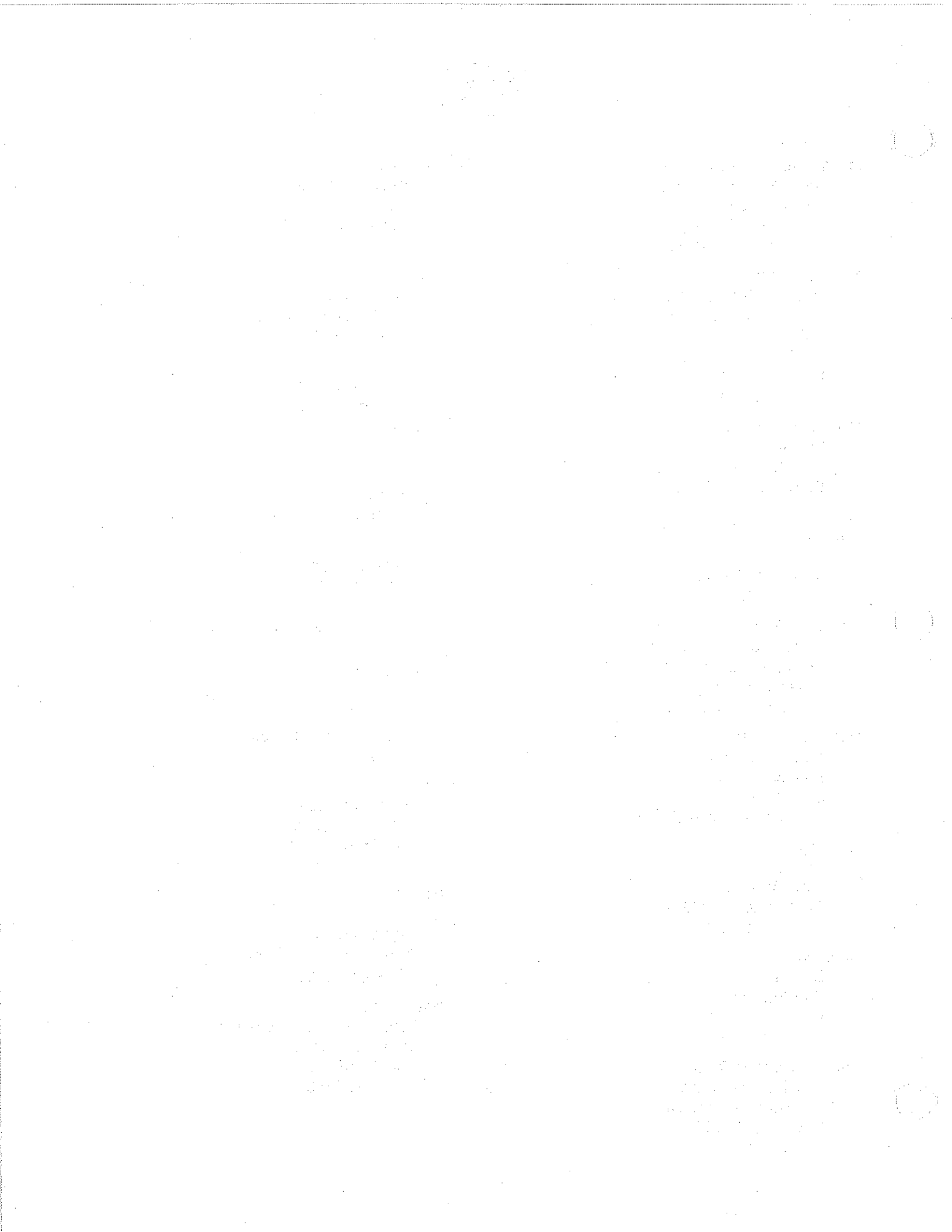

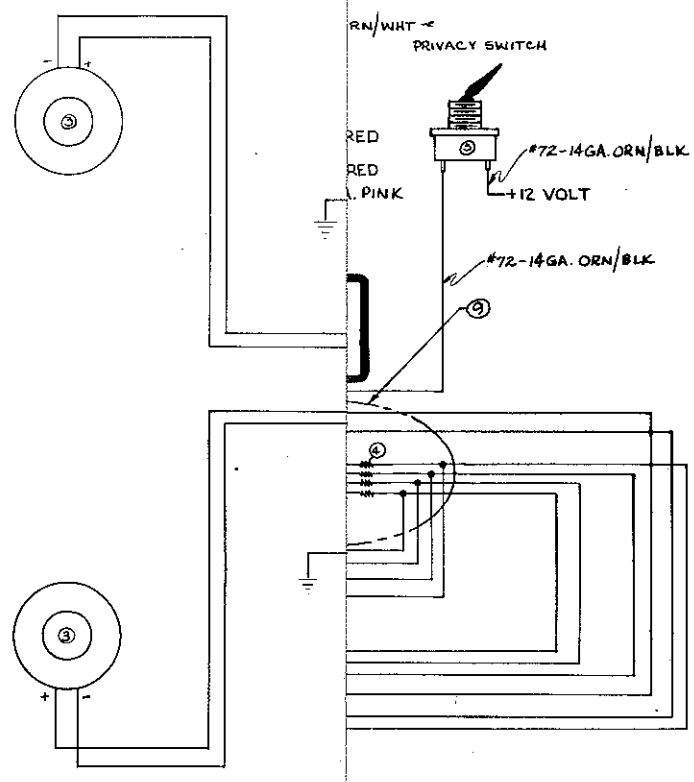
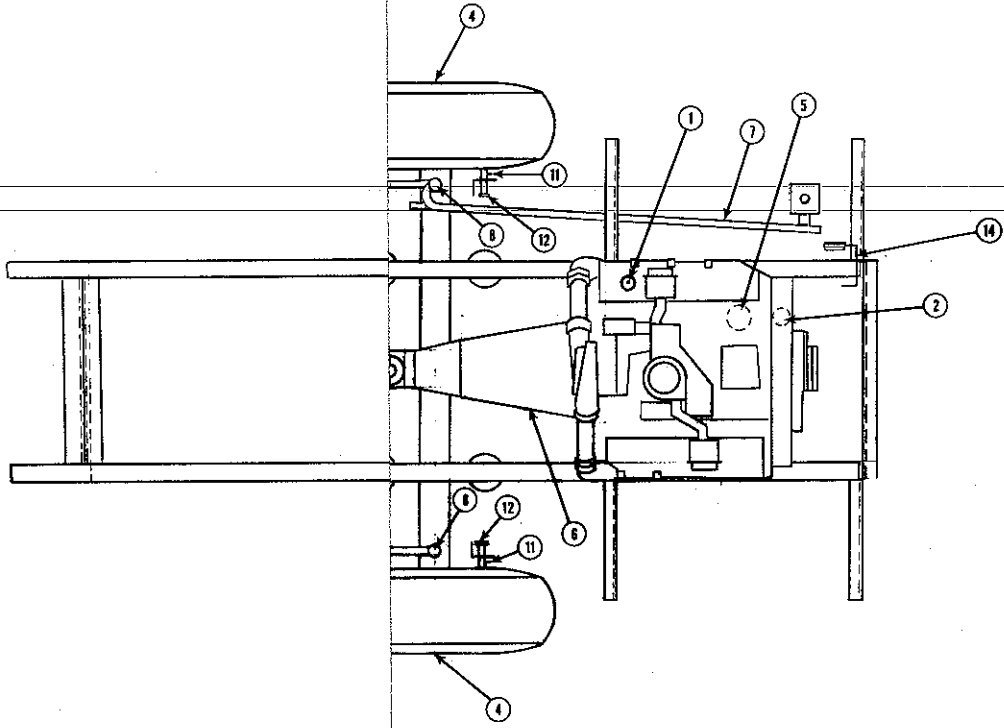

Figure 10-9. Diagram, Wiring Blaupunkt Stereo





KEY	SERVICE PERIOD	CHECK	DESCRIPTION	LUBRICANT
1.	SEE OWNERS MANUAL	DAILY	ENGINE OIL	CHECK LEVEL
2.	SEE OWNERS MANUAL	—	ENGINE OIL FILTER	FOLLOW EX MANUFACTURER'S RECOMMENDATIONS
3.	*25,000 MILES OR 6 MONTHS	1,000 MILES	REAR AXLE	KEEP OIL LEVELS FULL AND REFILL AS NECESSARY AND THEN CHECK LEVELS AT EACH STOPMASTER
4.	ONCE A YEAR	1,000 MILES	WHEEL BEARINGS FRONT AXLE	CHANGE LUBRICANT AND BEARING CAPS REPLACED AT LEAST EVERY 1,000 MILES
5.	NOT REQUIRED	5,000 MILES	HYDRAULIC POWER STEERING PUMP	NO PERIODIC LUBRICATION REQUIRED
6.	SEE GENERAL INSTRUCTIONS	MONTHLY	AUTOMATIC TRANSMISSION (ALLISON)	EXTERNAL LUBRICATION AT NORMAL OPERATING TEMPERATURES INTERNAL LUBRICATION WITH SAE 30 OIL-25,000 MILES
7.	*5,000 MILES OR 6 MONTHS	—	STEERING LINKAGE (DRAG ROD)	5-FITTING WITH POINT

Figure 10-14. Chassis Lubrication Guide

10

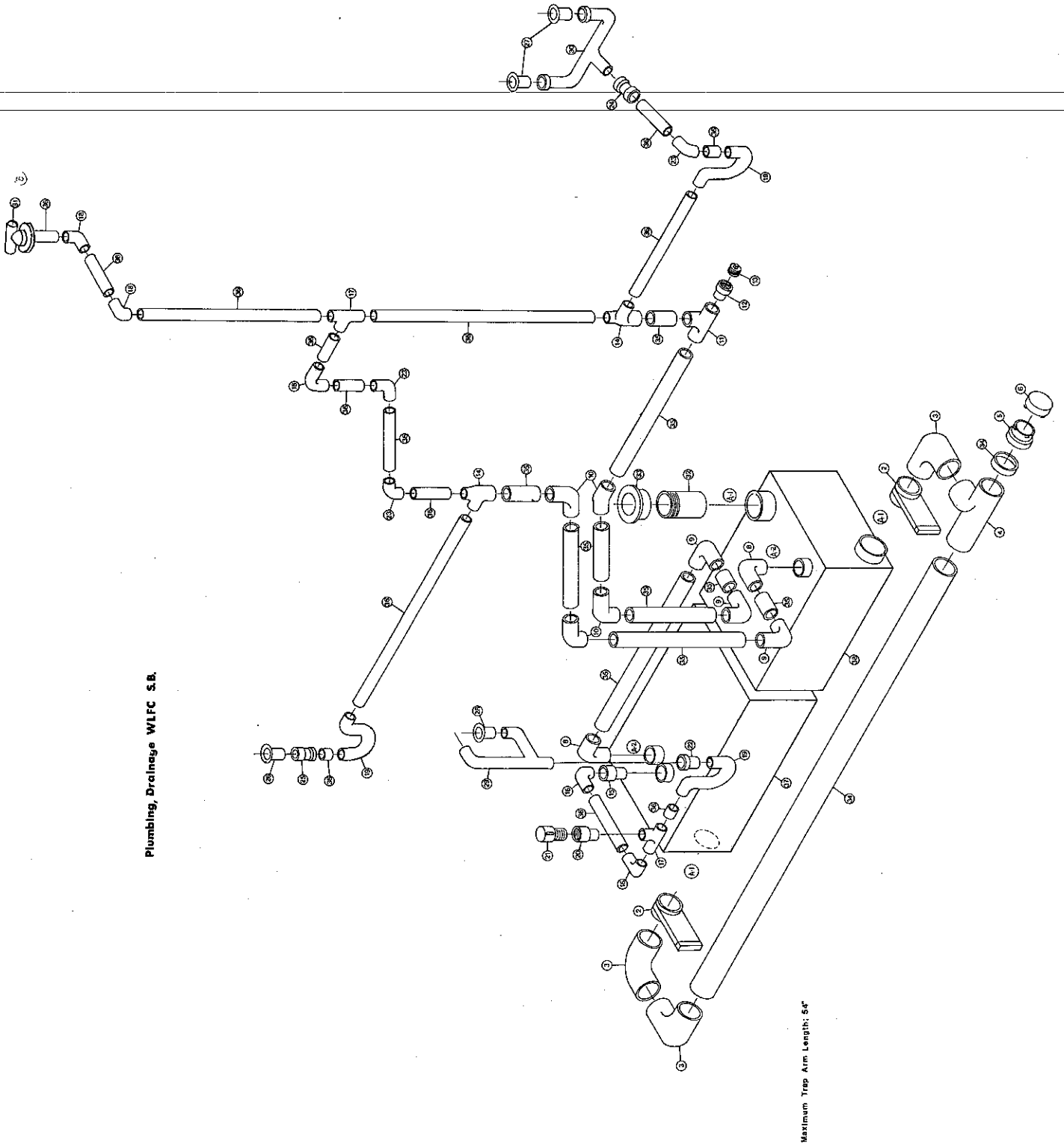

Plumbing, Drainage WLFC S.B.

Maximum Trap Arm Length: 5'

Figure 10-11. Drainage System



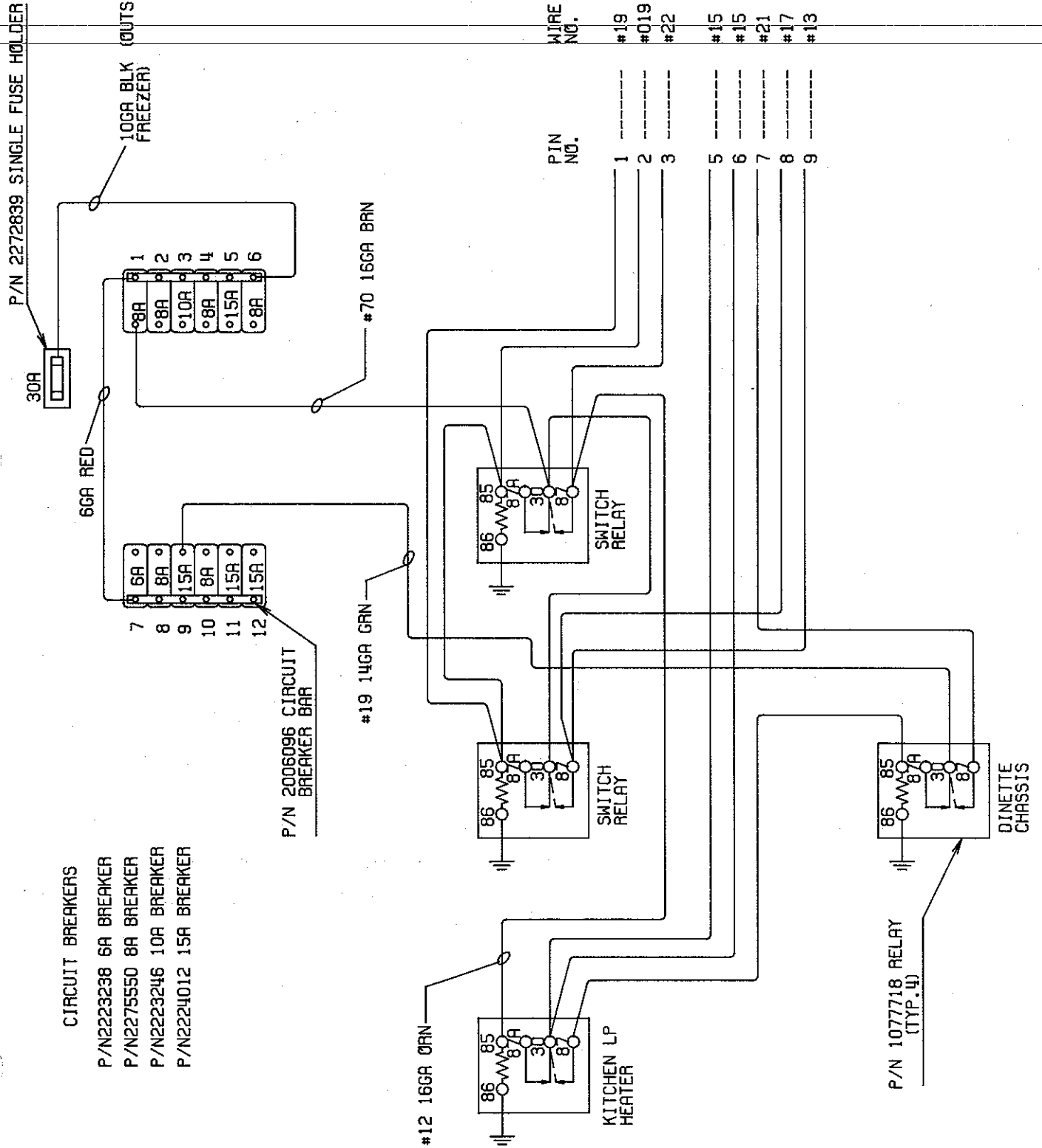

Figure 10-5. 12 Volt Diagram, Right Front Load Center (Sheet 1)



18 PIN AMP MALE PLUG

PIN NO.	CIRCUIT BREAKER		DESCRIPTION
	NØ.	SIZE	
1 -----	1 -----	8A -----	16GA #9 GREY- PORCH LIGHT
2 -----	1 -----	8A -----	16GA #6 GRN- PIN #7 ON STEP RELAY
3 -----	4 -----	8A -----	16GA #23 BLUE- LIVINGROOM READING LIGHTS
4 -----	2 -----	8A -----	16GA #11 TAN- DINETTE READING LIGHTS
5 -----	5 -----	15A -----	14GA #25 YEL- LIVINGROOM FLUØ. LIGHT SWITCH
6 -----	2 -----	8A -----	18GA #15 BLK- HALF-CLOSET LIGHT SWITCH
7 -----	7 -----	6A -----	14GA #9 RED- TV ROTØR & ANTENNA BOOSTER
8 -----	3 -----	10A -----	16GA #13 RED/BLACK- 12VDC OUTLET Ø HALF-CLOSET
9 -----	10 -----	8A -----	16GA #12 RED/BLACK- 12VDC OUTLET (FRONT)
10 -----	6 -----	8A -----	16GA #26 BRN/ØRN- ENTRANCE & DINETTE FLUØ. LGT. SWITCH
11 -----	11 -----	15A -----	14GA #1 RED- ANTENNA LIFT MØTØR
12 -----	6 -----	8A -----	16GA #41 PINK- GENERATØR IN/ØUT SWITCH CHANGE ØVER COMP.
13 -----	6 -----	8A -----	18GA #15 ØRN- DINETTE THERMØSTAT POWER

18 PIN AMP FEMALE PLUG

1 -----	16GA #19 TAN- FROM SUM/WIN SWITCH
2 -----	16GA #019 TAN- TO SUM/WIN RELAY
3 -----	16GA #22 ØRN- DINETTE THERMØSTAT POWER
5 -----	18GA #15 PINK- DINETTE THERMØSTAT TO RELAY
6 -----	18GA #15 PINK- KITCHEN LP HEAT RELAY
7 -----	14GA #21 GREEN- DINETTE CHASSIS HEATER
8 -----	16GA #17 GRN/BLK- BEDROOM THERMØSTAT RELAY
9 -----	16GA #13 BRN/ØRN- BATHROOM THERMØSTAT RELAY

Figure 10-5. 12 Volt Diagram, Right Front Load Center (Sheet 2)

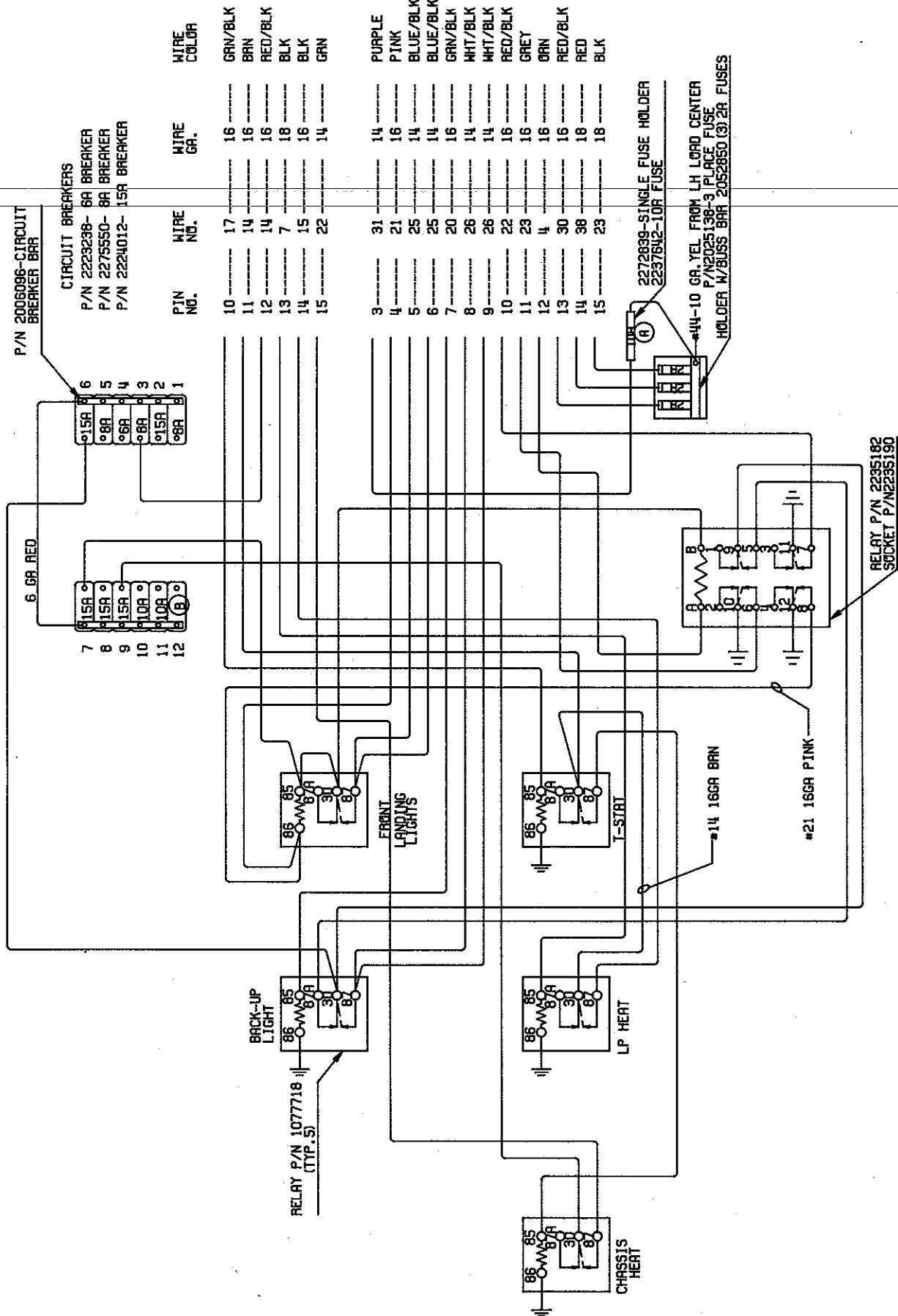

Figure 10-6. 12 Volt Diagram, Left Rear Load Center (Sheet 1)



18 PIN AMP MALE PLUG

PIN NO.	CIRCUIT BREAKER		DESCRIPTION
	NO.	SIZE	
1 -----	1 ----	8A	16GA. #14 GREY- CLOSET LIGHTS
2 -----	11 ----	10A	14GA. #20 BLUE- READING LIGHTS LH BEDROOM
3 -----	11 ----	10A	16GA #43 GRN- ELECTRIC DOOR LOCK SWITCH
4 -----	4 ----	6A	18GA #17 BLK- WATER BLOW-OUT SWITCH
5 -----	4 ----	6A	16GA #16 BRN/ORN- WATER FILL SWITCH
6 -----	5 ----	8A	14GA #1 GRN/WHT- WATER PUMP
7 -----	8 ----	15A	14GA #8 RED- LP HEATER
8 -----	4 ----	6A	18GA #18 BLK- WATER HEAT PROTECTOR SYSTEM
9 -----	10 ----	10A	16GA #10 BRN- TO AISLE LIGHT SWITCH
10 -----	----	----	16GA #17 GRN/BLK- BEDROOM THERMOSTAT RELAY
11 -----	----	----	16GA #14 BRN- FROM BEDROOM THERMOSTAT
12 -----	----	----	16GA #14 RED/BLK- TO BEDROOM THERMOSTAT
13 -----	----	----	18GA #7 BLK- LP SELECTOR SWITCH
14 -----	----	----	16GA #15 BLK- TO THERMOSTAT WIRE • LP HEATER
15 -----	----	----	14GA #22 GRN- CHASSIS HEAT BEDROOM SWITCH
16 -----	----	----	16GA #18 WHT/GRN- REFRIGERATOR VENT FAN

18 PIN AMP FEMALE PLUG

3 -----	(B) 14GA #31 PURPLE- MARSHALL BRASS
4 -----	16GA #21 PINK- LANDING LIGHT SOLENOID, FRONT
5 -----	14GA #25 BLUE/BLK- FRONT LANDING LIGHTS
6 -----	14GA #25 BLUE/BLK- FRONT LANDING LIGHTS
7 -----	16GA #20 GRN/BLK- SECURITY BACKUP RELAY
8 -----	14GA #26 WHT/BLK- SECURITY BACKUP LIGHT
9 -----	14GA #26 WHT/BLK- SECURITY BACKUP LIGHT
10 -----	16GA #22 RED/BLK- SOLENOID, DRIVERS TOE BOARD
11 -----	16GA #23 GREY- REAR LANDING LIGHT SOLENOID, FRONT LH LOAD CENTER
12 -----	16GA #4 ORN- BEDROOM SECURITY LIGHT SWITCH
13 -----	16GA #30 RED/BLK- PMMI PANEL- HOT
14 -----	18GA #38 RED- ALARM CLOCK- BEDROOM
15 -----	18GA #23 BLK- DOOR CHIME

Figure 10-6. 12 Volt Diagram, Left Rear Load Center (Sheet 2)

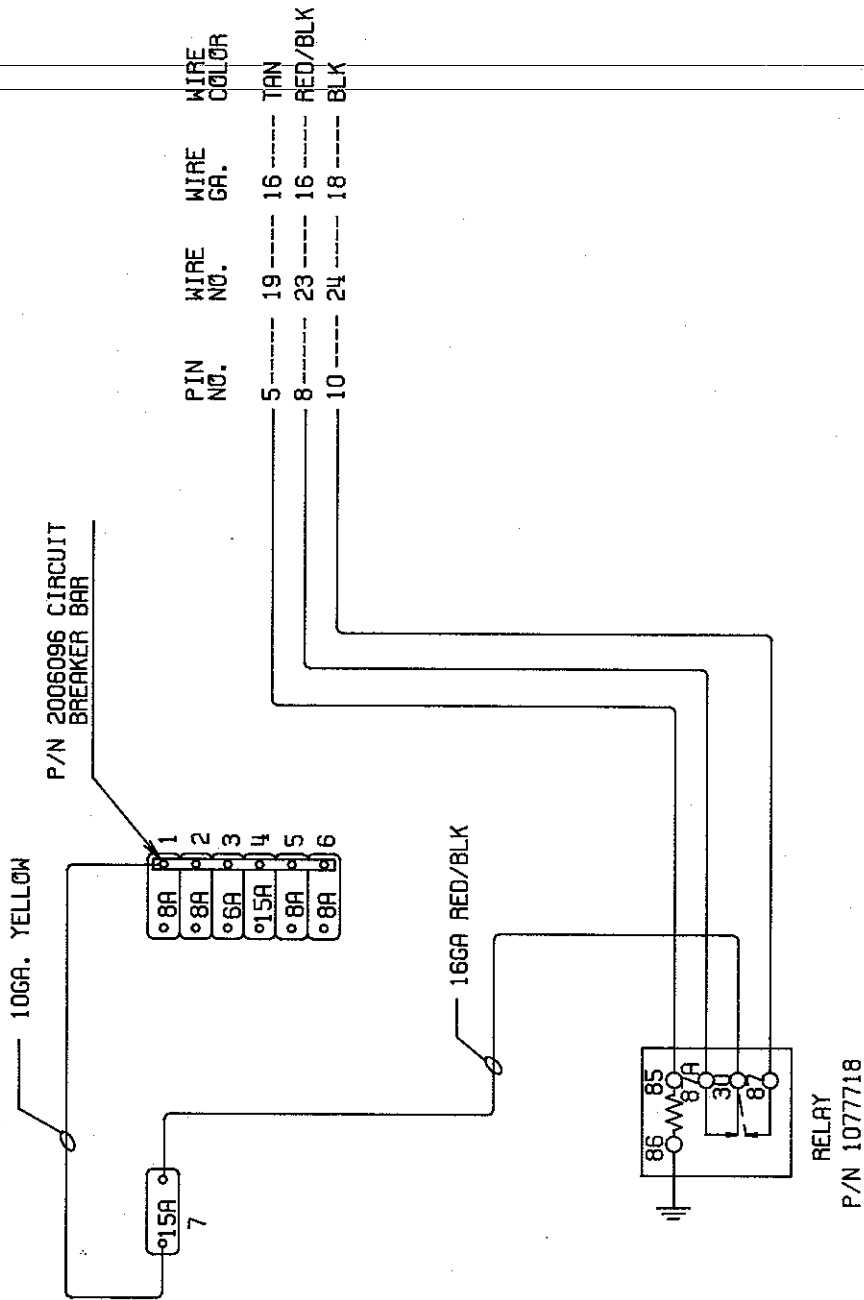

Figure 10-7. 12 Volt Diagram, Right Rear Load Center (Sheet 1)



18 PIN AMP MALE PLUG

PIN NO.	CIRCUIT BREAKER		DESCRIPTION
	NO.	SIZE	
1 -----	1 -----	8A -----	16GA #25 GRN/WHT- KITCHEN FLUØ. CEILING LIGHT
2 -----	2 -----	8A -----	16GA #21 RED/BLK- 12VDC OUTLET, BEDROOM
3 -----	4 -----	15A -----	14GA #27 YEL- BEDROOM FLUØ. LIGHT & HALL FLUØ. CEILING LIGHT
4 -----	5 -----	8A -----	14GA #26 BLUE- READING LIGHTS BEDROOM
5 -----	-----	-----	16GA #19 TAN- TØ SWITCH RELAY RH FRONT LOAD CENTER
6 -----	1 -----	8A -----	16GA #18 ØRN- A/C SWITCH RELAY
7 -----	3 -----	6A -----	16GA #1 GRN/BLK- CLOSET LIGHT SWITCHES RH
8 -----	-----	-----	16GA #23 RED/BLK- WINTER SOLENOID VALVE
9 -----	6 -----	8A -----	16GA #2 GREY- CAMERA DEFØG
10 -----	-----	-----	18GA #24 BLK-SUMMER SOLENOID VALVE

Figure 10-7. 12 Volt Diagram, Right Rear Load Center (Sheet 2)

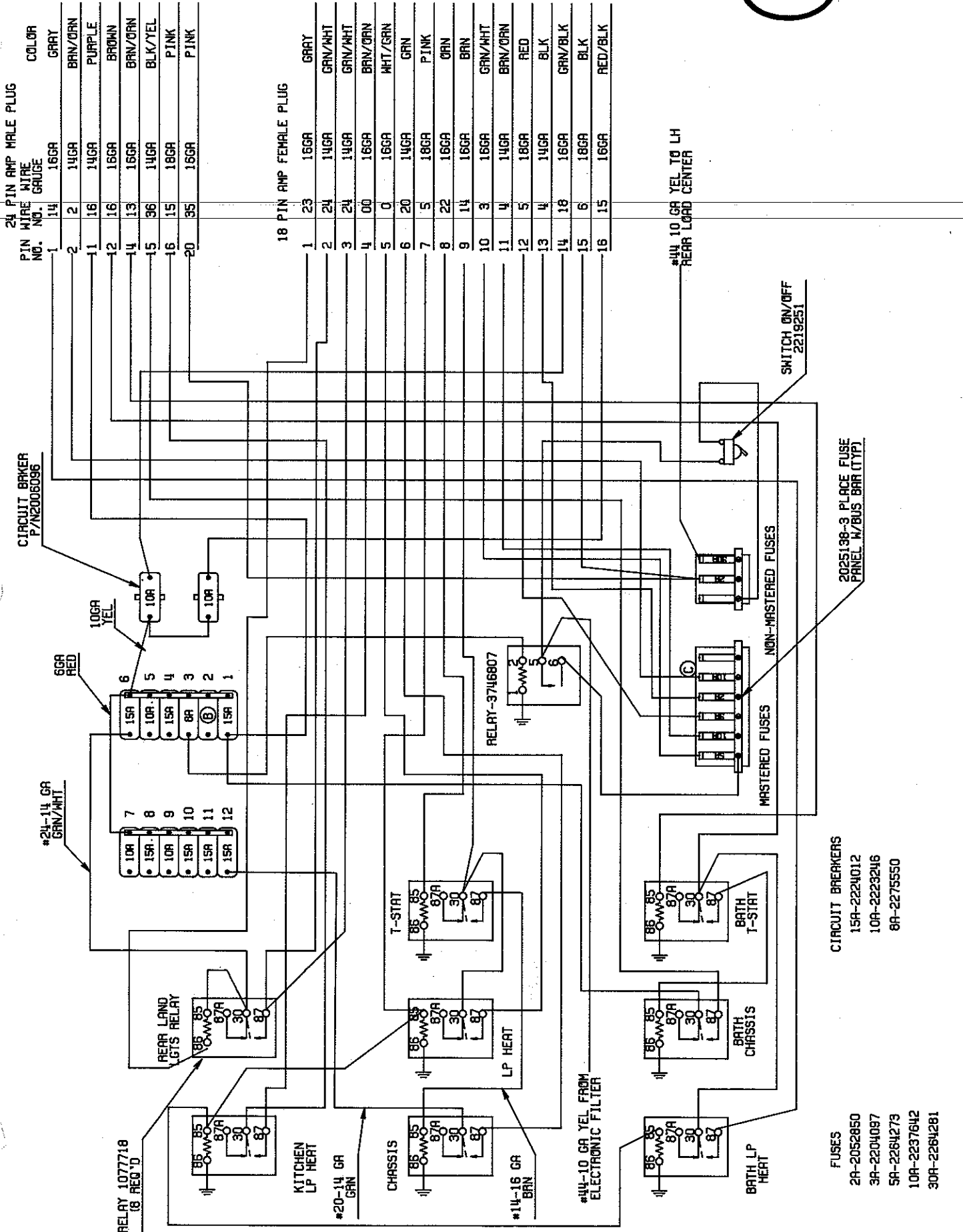

24 PIN AMP MALE PLUG

PIN NO.	WIRE GAUGE	COLOR
1	14	GRAY
2	14GA	BRN/ORN
11	16	PURPLE
12	16	BROWN
14	13	BRN/ORN
15	36	BLK/YEL
16	15	PINK
20	35	PINK

18 PIN AMP FEMALE PLUG

1	23	GRAY
2	14GA	GRN/WHT
3	14GA	GRN/WHT
4	00	BRN/ORN
5	0	WHT/GRN
6	20	GRN
7	5	PINK
8	22	GRN
9	14	BRN
10	3	GRN/WHT
11	4	BRN/ORN
12	5	RED
13	4	BLK
14	18	GRN/BLK
15	6	BLK
16	15	RED/BLK

- CIRCUIT BREAKERS**
- 15A-2224012
 - 10A-2223246
 - 8A-2275550

- FUSES**
- 2A-2052850
 - 3A-2204087
 - 5A-2264273
 - 10A-2237642
 - 30A-2264281

Figure 10-4. 12 Volt Diagram, Left Front Load Center (Sheet 1)



24 PIN MALE PLUG

CIRCUIT BREAKER NO.	PIN NO.	WIRE NO.	WIRE GAUGE	COLOR	DESCRIPTION
	1	14	16 GA.	GRAY	BOOSTER CONTROLLER BOX
	2	2	14 GA.	BRN/ORN	12 VDC INVERTER SWITCH
3	3	25	16 GA.	LGT GREEN	BATH AND KITCHEN VENT FAN
4	4	28	14 GA.	YELLOW	FLUO. LGT KITCHEN AND O.H. CABINETS
5	5	20	16 GA.	BLUE	READING LGTS LIVINGROOM
9	6	38	14 GA.	BLACK	FRONT 12V STEREO AMP
7	7	65	14 GA.	YEL/BLK	REAR 12V STEREO AMP
11	8	10	14 GA.	YEL/BLK	KITCHEN LP HEATER
5	9	72	14 GA.	ORN/BLK	12V STEREO SWITCH AND RELAY
8	10	23	14 GA.	BRN/ORN	VENT FAN LIVINGROOM
	11	16	14 GA.	PURPLE	DUCT BOOSTER
	12	16	16 GA.	BROWN	BATHROOM THERMOSTAT
10	13	12	14 GA.	RED	LIVINGROOM LP HEATER
	14	13	16 GA.	BRN/ORN	SUM/WIN SWITCHING RELAY
	15	36	14 GA.	BLK/YEL	BATHROOM CHASSIS HEAT
	16	15	18 GA.	PINK	KITCHEN THERMOSTAT
3	17	16	16 GA.	RED/BLK	BATHROOM THERMOSTAT POWER
5	18	4	18 GA.	RED	BATHROOM WATER PUMP LIGHT
3	19	14	16 GA.	RED/BRN	LIVINGROOM THERMOSTAT POWER
	20	35	16 GA.	PINK	12V STEREO MEMORY

18 PIN FEMALE PLUG

PIN NO.	WIRE NO.	WIRE GAUGE	COLOR	DESCRIPTION
1	23	16 GA.	GRAY	REAR LAND LGT RELAY
2	24	14 GA.	GRN/WHT	REAR LAND LGT
3	24	14 GA.	GRN/WHT	REAR LAND LGT
4	00	16 GA.	BRN/ORN	T-STAT WIRE AT KIT LP HEAT
5	0	16 GA.	WHT/GRN	T-STAT WIRE AT LP HEAT
6	20	14 GA.	GREEN	LIVINGROOM CHASSIS HEAT SW
7	5	18 GA.	PINK	LIVINGROOM LP HEAT SW
8	22	16 GA.	ORANGE	CHASSIS SUM/WIN RELAY
9	14	16 GA.	BROWN	LIVINGROOM THERMOSTAT
10	3	16 GA.	GRN/WHT	12V STEREO RADIO
11	4	14 GA.	BRN/ORN	PMMI MUSICAL HORN
12	5	18 GA.	RED	CB RADIO
13	4	14 GA.	BLACK	INTERCOM
14	18	16 GA.	GRN/BLK	BATH READING/SHOWER LGT
15	6	18 GA.	BLACK	POWER FOR DASH CLOCK
16	15	16 GA.	RED/BLK	12V OUTLET IN BATH/STOVE LGT

Figure 10-4. 12 Volt Diagram, Left Front Load Center (Sheet 2)

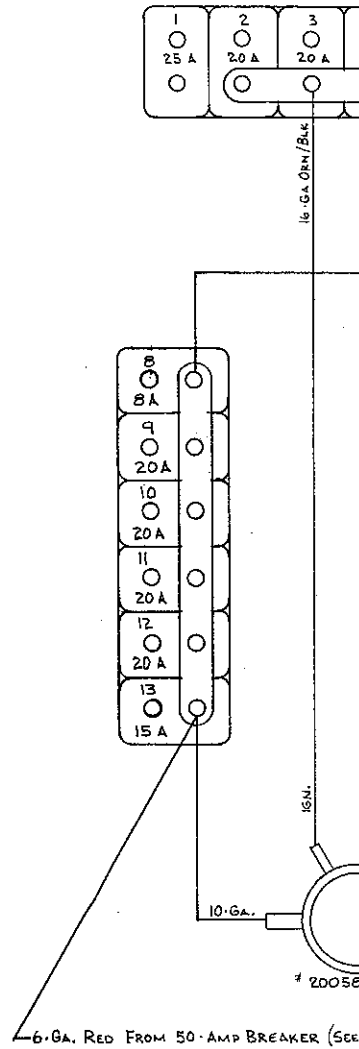

NOTE: Ⓢ DENOTES WIRES TO BE EXTENDED OFF BREAKERS 24" @ THE TOP OF THE BREAKER PANEL.

ALL OTHER WIRES WILL BE CONNECTED AFTER PANEL IS INSTALLED IN THE COACH.

Figure 10-2. 12 Volt Diagram, Lower Front Load Center





N. HOT FROM
NEL

#44-BLUE 14 GA. RH TURN SIGNAL
#43-RED 14 GA. LH TURN SIGNAL
#14-BLUE 14 GA. RH DIR.
#13-RED 14 GA. LH DIR.

#31-GREEN 14 GA. MARKER LIGHTS
#49-BLACK 14 GA. 12 VOLT RECEPT.*
#41 RED 14 GA. SPOTLIGHT. L&R CONT
#42-RED 14 GA. SPOTLIGHT SWITCH*
#1-PURPLE 14 GA. HEAT BARRIER FAN

DIR. RELAY HOT FROM
KER PANEL
- HEADLIGHT WARNING LIGHT
- HEADLIGHT WARNING BUZZER
- AUX WATER PUMP SWITCH*
A. SUM/WINTER SWITCH*
- SUM VALVE/IGN. CHASSIS HTR
- CHASSIS A/C SWITCH LEFT*
A. CHASSIS A/C SWITCH RIGHT*
CHASSIS A/C RELAY*
- REAR CAMERA TRIGGER
- TRIP ODOMETER
RACOR FILTER SENSOR LIGHT
SAFE-LINE
ANT. INDICATOR LIGHT*

2 A

#40-RED 16 GA. SPOTLIGHT SPEED
6 GA. RED (SEE DWG)

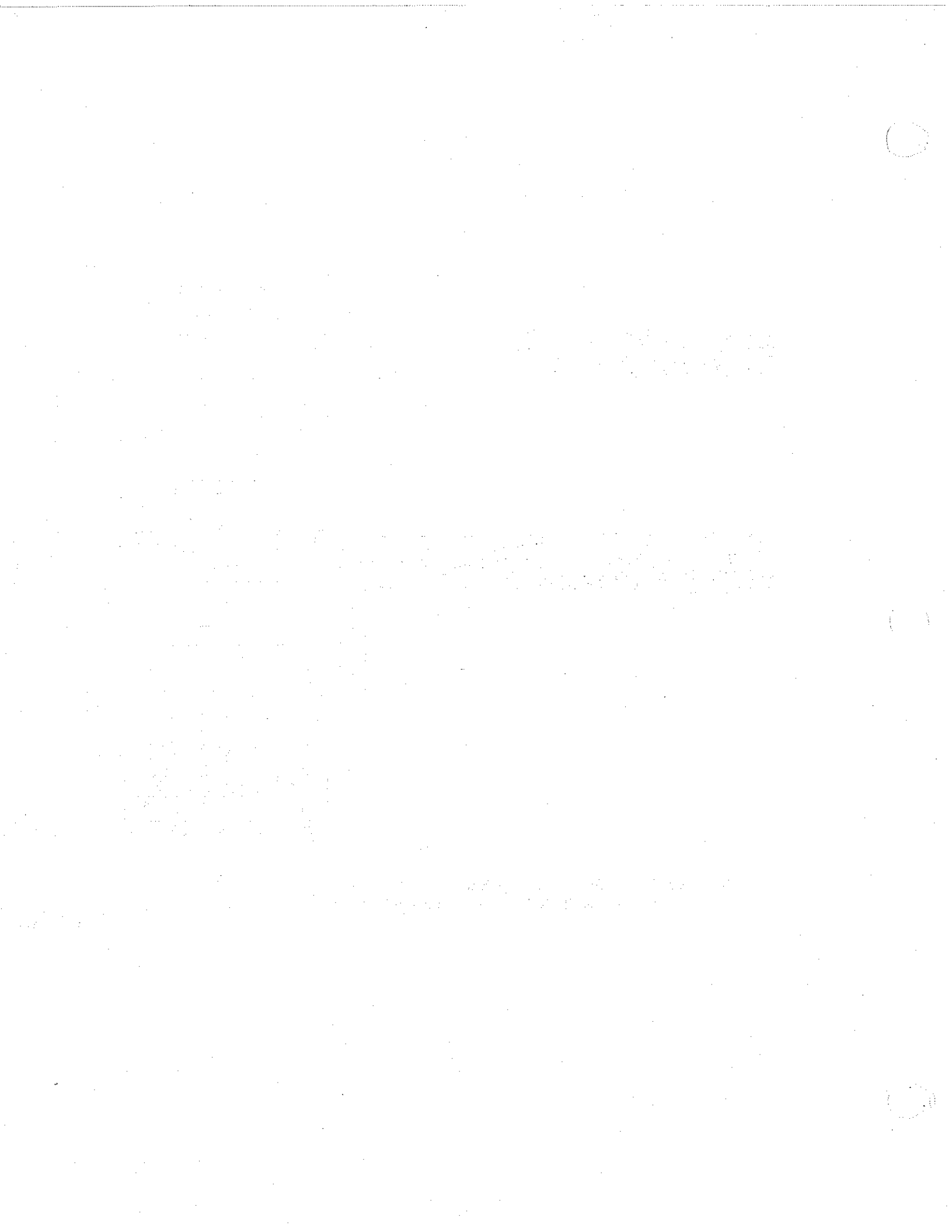

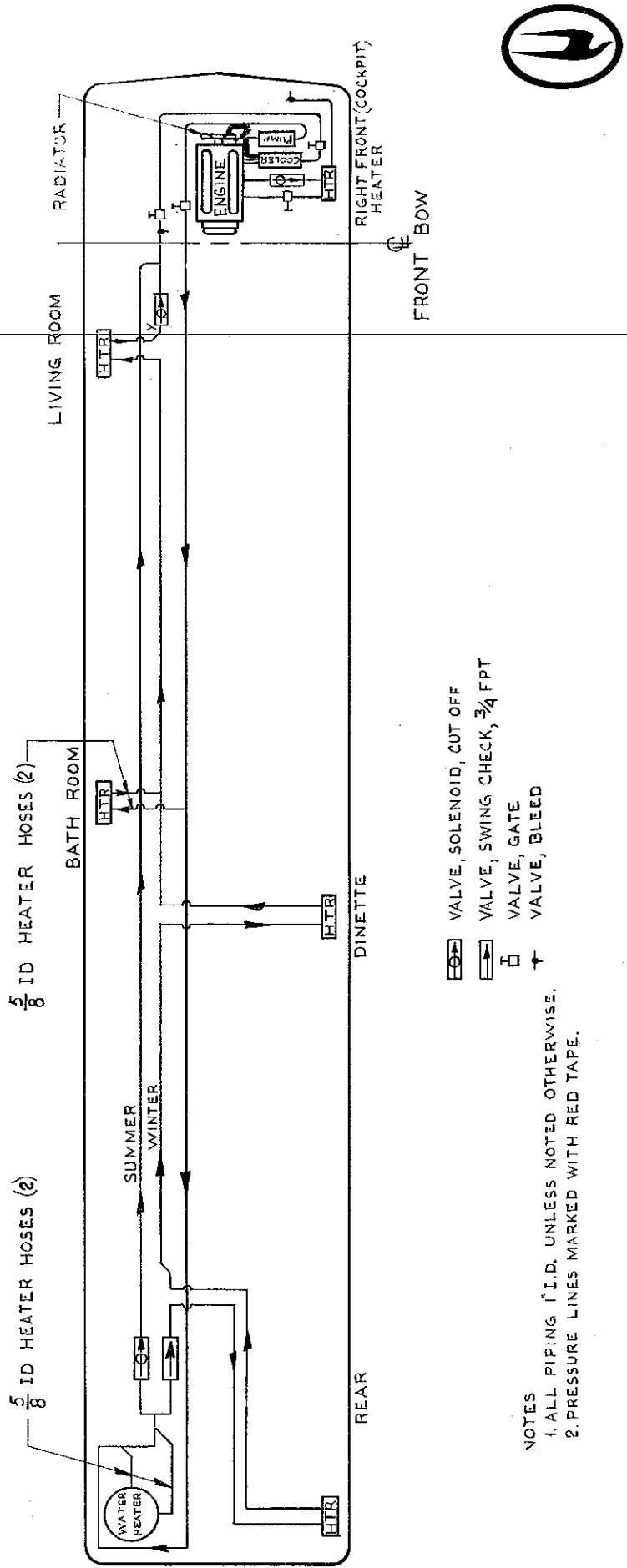

Figure 10-1. Diagram, Chassis and Water Heater Circuits

100

(2)

(2)

(2)

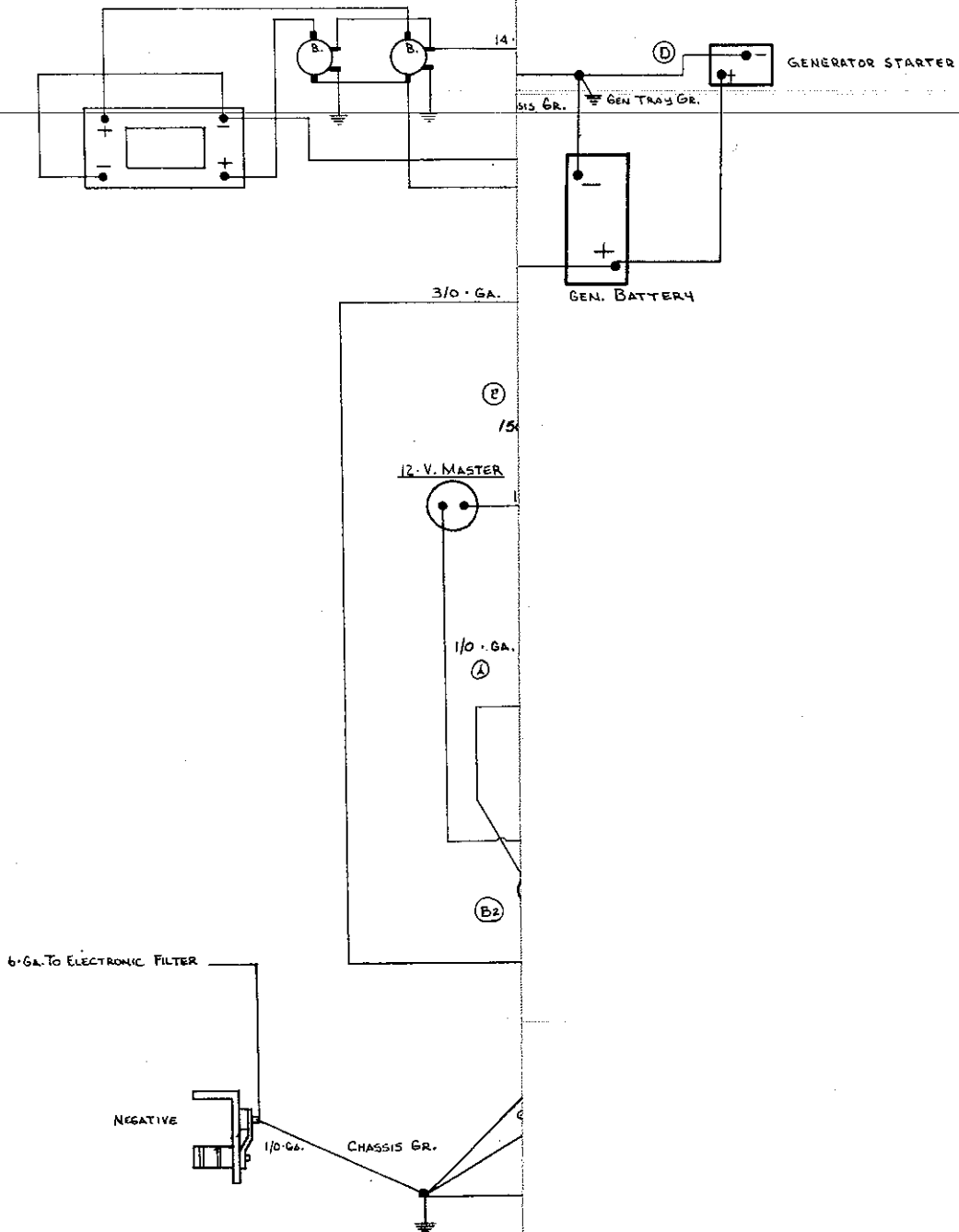
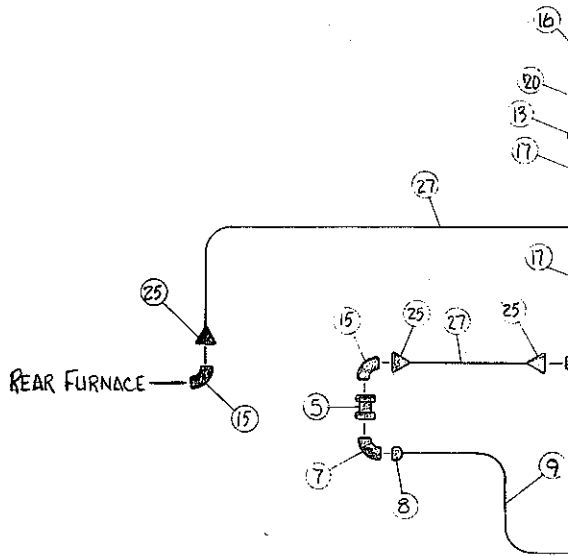

Diagram 10-8. 12 Volt Diagram, Batteries and Charging Circuits





ITEM NO.	PART NO.	DESCRIPTION	QTY.
1	0929554	Tank, LPG	1
2	1019231	Regulator, High, Pressure	1
3	0654277	Tee, 1/4" Street	1
4	0976068	Hose, LPG	1
5	2023232	Coupling, 1/4"	2
6	2027183	Nipple, 1/4" Close	1
7	2026987	Elbow, 1/4 x 3/8 IF	2
8	2026821	Nut, 3/8" IF	2
9	2027381	Tubing, 3/8" Copper	22 ft.
10	2254050	Valve, Range	1
11	3757499	Valve, Furnace	4
12	2245454	Valve, LPG Shut Off	2
13	2259307	Regulator, Low Pressure	2
14	2259315	Valve, Auto, Shut Off	1
15	2260719	Elbow, 1/4 P. x 3/8 Fl.	6
16	2222727	Ell, St. 1/2 P.	2
17	2253979	Connector 1/4 P. x 3/8 Fl.	3
18	2257897	Connector 1/2 P. x 3/8 Fl.	1
19	2240117	Connector 1/8 P. x 3/8 Fl.	1
20	2222735	Nipple, Hex. 1/2 P. x 3/8 P.	5
21	2196459	Nipple, 1/2 Close	5
22	2257905	Cross, 1/2 P.	2
23	2265106	Coupling, Anchor 1/4 P.	1
24	2207157	Cap, 3/8 Fl.	1
25	3743994	Nut, 3/8 Fl. Forged	18
26	2266054	Socket, Quik Disconnect	1
27	2027381	Tubing, 3/8 Copper	1

Figure 10-12. Liquid Petroleum Gas System





Section XI

Equipment Options

Awnings

The awnings are standard equipment on your coach and designed for simplicity of operation and long-term use. To open the awning, refer to the figures below and proceed as follows:

Open Awning

1. Pull down on Z lock lever, as shown in **figure 11-1**, to permit awning to be unrolled.

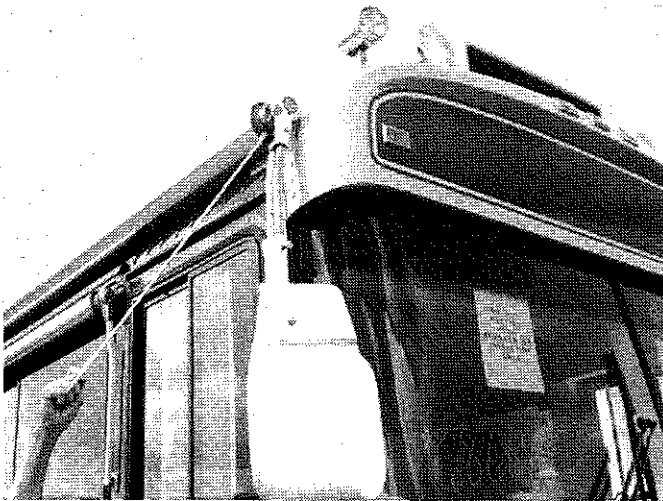

Figure 11-1.

2. Completely unroll awning by first pulling the tab toward you with the hook and then grasping strap with hands as shown in **figure 11-2**. Fold or roll the strap so the Velcro strips meet and hold tab in place next to the roller. Now move beneath the awning and proceed with step 3.
3. Release the ratchet stud on the rafter arm. Swing the arm toward the case and engage the hook section of the claw in the rafter lock, **figure 11-3**. Lock the rafter arm by pressing down on main arm bar, making the fabric taut, until the ratchet stud engages.

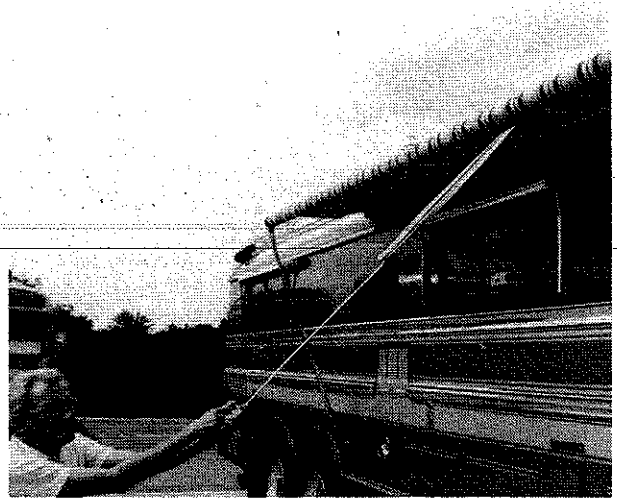

Figure 11-2.

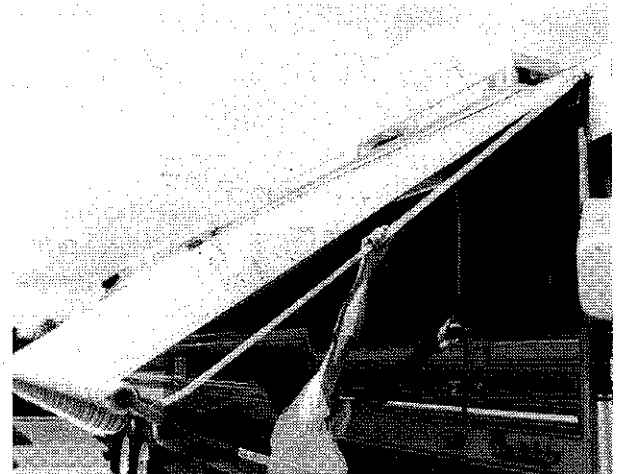

Figure 11-3.

4. Referring to **figure 11-4**, raise awning to desired height by releasing snap stud on main arm and pushing up and out on roller assembly. Lean, so that body weight — rather than arm strength — carries out this step.

Caution

Be sure to raise high enough to allow for clearance with the top of the door.

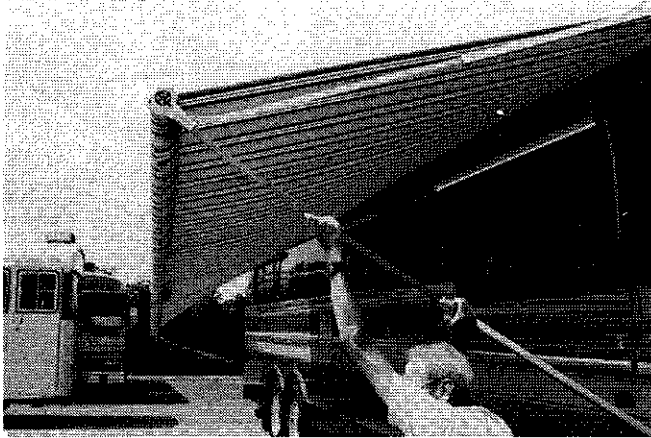

Figure 11-4.

5. Repeat steps 3 and 4 at other end of awning.

Close Awning

1. Lower awning to bottom position by releasing snap studs and dropping roller assembly.
2. Release ratchet stud on rafter arms and lift the claws out of the rafter locks.
3. Place arm claw casting end against protruding screw. To lock assembly, push rafter tube toward coach body until ratchet stud engages. Repeat at other end of awning.
4. Roll awning against coach using the pull tab to guide.
5. Lock the awning in place for travel by pushing up the **Z** lock lever.

Note

The tab must be spiraled around the roller to prevent a loose roll and the bunching-up of fabric.

6. Observe if the roll-up is even and in-line with clamps. If not, then unroll and give roller a slight push toward the direction required to line up the roller. If you wish to have the awning roll up more in either direction spiral the pull tab in that direction.

Fabric Care

The fabric of your awning is made of acrylic fibers which cannot rot or mildew. Your awning can be rolled up wet if necessary, but be sure to open it to dry as soon as possible.

The acrylic fabric of your awning is a synthetic

and cannot support mildew or other plant growth. However, mildew can find a home on any pollen, grain dust, plant spores, or other airborne plant material that can accumulate on the awning. If mildew forms on any of these elements, it can leave a stain which can be unsightly and difficult to remove, even though it will not weaken the fabric itself. To minimize the chance of a stain, keep your awnings as clean and dry as possible by hosing it down frequently between seasonal washings.

Washing

On a monthly basis, loosen hardened dirt and dust with a dry, medium bristle brush, then thoroughly rinse both top and bottom with a hose. For more stubborn stains, use a mild solution of 1/2 cup bleach and 1/2 cup soap flakes diluted in one gallon of lukewarm water.

Wash both sides of the awning with the solution while scrubbing with a soft brush. Saturate the fabric and leave the solution on for 15-20 minutes. (Keep the fabric saturated by reapplying solution as needed.) Rinse **thoroughly**. Repeat if necessary until most of the stains disappear.

Caution

Never use a strong detergent (super spray) or stain remover on your awning. These can destroy the water repellency of the fabric.

Water Leaks

If leaking occurs after washing, it is usually the result of insufficient rinsing. If water drips through the needle holes in the stitching, you can use a commercial seam sealer available in canvas and trailer supply stores. You may also apply a paraffin wax to the top of the seams. However, as the awning **weathers**, these holes will normally seal themselves.

It is normal for slight leakage to occur through the fabric where water is allowed to accumulate or **pocket** on the fabric. See **Storm Precautions** for information on awning settings for proper water drainage. Sometimes soap or chemical residue, such as from active agents in insect fogs or sprays, can wet the fabric so that it appears unable to repel water. Rinse the fabric thoroughly and test for water repellancy after it dries. If leakage continues, wash the fabric or contact the manufacturer for in-



formation on treating the fabric.

Storm Precautions

Because there is no warranty for damage caused by acts of God, steps should be taken to prevent damage from occurring due to wind, rain or storm.

If you are leaving or retiring for the night, close the awning. This takes only a few seconds (less time than closing your windows) and gives you the best protection. If for some reason you can't close the awning, lower both ends of it as far as you can without removing the spring arms. This will create a sufficient slope for water run-off. If you are remaining with the awning, you may lower one end only sufficiently to divert water.

Hardware and Mechanism Maintenance

Although your awning requires less maintenance than any other awning, a little care (about the same amount that you give to your coach) will keep the metal parts in top shape. The rafter arm assemblies, main arm tubes, and the awning case are bright-anodized aluminum; the castings are polished, high-strength aluminum alloys. To keep these parts new looking they should be cleaned once a year with a good quality chrome or aluminum polish.

The main arm bar and all fasteners and stress bearing shafts are stainless steel. These need only be cleaned occasionally to remove accumulated grime that might hinder their operation.

At the end of each season:

- Tighten any loose bolts or screws. (Replace missing parts only with factory authorized replacements.)
- Polish accessible hardware.
- Use a silicone lubricant only on the 1/2" round shafts that protrude from each end of the roller.
- Extend all telescoping arms as far as possible to wipe off accumulated sand and dirt that can clog and scratch the protective aluminum finish.

Ice-Maker

The ice-maker, figure 11-5, is designed to provide a continuous automatic supply of ice cubes. It will operate unattended providing that the water supply line is open and the ac power is applied to the unit. This may be supplied from shorepower, the power generator, or from the optional motor generator (Redi-Line).

Ice-Maker Operation

The power on-off switch is located on the front grillework. When the ice cube supply is full, the ice-making mechanism shuts off automatically. However, the refrigeration system continues to operate to prevent the prepared ice cubes from melting. When removing cubes, do not use a sharp instrument to separate the cubes that are frozen together or the interior may be damaged.

Note that the ice-maker may supply small cubes the first time that it is used. This is due to accumulated air in the water line and subsequent batches will be normal-sized.

If the machine is used only intermittently, empty the ice periodically (every week to 10 days) to ensure a fresh supply of cubes.

Do not clean the cabinet interior with solvent-type cleaners, abrasives, or other cleaners that might cause ice cubes to acquire a bad taste. The exterior should be cleaned with a furniture-type cleaner/polish. Clean condenser (behind grille) with a blower/vacuum at least 3 to 4 times each year, depending on usage.

Caution

The ice-maker grille must be free from all obstructions. Any interference with free air flow to the grille will cause faulty operation.

To shut down the ice-maker, set power switch to off, and remove all cubes. Leave the door slightly ajar for ventilation to avoid mold or odors.

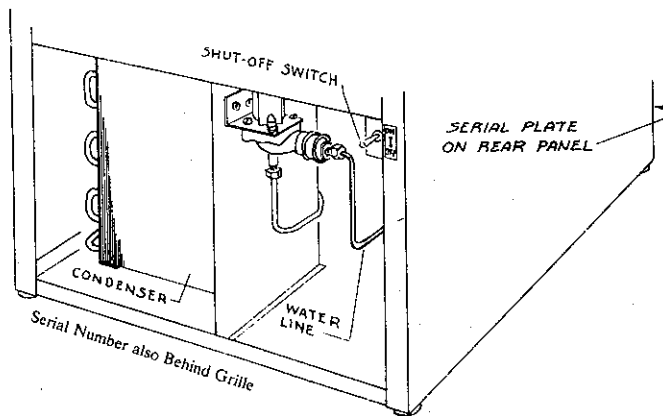

Figure 11-5 Ice-Maker Details.

Ice-Maker Maintenance

Other than periodic cleaning of grillework, condenser and interior, no other maintenance procedures are required. Remove the grille as follows: take out screw at top, put fingers in slots and lift up and out.

Winterizing

Follow procedure in Section V. To facilitate draining of water line, remove garden hose type fitting shown in figure 11-5

Microwave/Convection Oven

The microwave/convection oven provides programmed microwave cooking, convection operation for crisp, even browning, or a combination of both.

Caution Notes:

1. Unlike microwave-only ovens, all microwave/convection ovens have a tendency to become hot on the cabinet and oven door, as do con-

ventional range ovens and convection-only ovens. Be careful when touching parts other than the handle or control panel during or immediately following cooking that uses convection heat.

2. Do not cook eggs in the shell. Steam builds up inside the shell and it may explode from pressure. Shelled hard-cooked eggs should be sliced or cut up before reheating in the microwave oven. You may hard-poach eggs for salads and casseroles.
3. Pop popcorn only in special microwave poppers, following manufacturer's directions. Do not use oil unless specified by the manufacturer, or heat longer than recommended. Never pop popcorn in paper bags or glass utensils.
4. Do not heat oil or fat for deep-frying. The temperature of the oil cannot be controlled and it may overheat.
5. Do not attempt to can in the microwave oven as it requires prolonged high temperatures.
6. Do not operate the oven empty.
7. Remove wire twist-ties from bags before placing in oven.

This oven uses a microprocessor, the electronic brain that provides a wide variety of cooking programs which could not be achieved by conventional control methods. The operation of the oven is controlled by touching the appropriate pads arranged on the surface of the control panel, figure 11-6. The lighted digital readout will display the cooking time, convection temperature, sensor or compu-cook setting, or time of day, and indicators show the variable cooking setting or cooking function you have programmed.

An audible entry signal tone should be heard each time you touch the control panel to make a correct entry. If you do not hear this sound,

1. You have not used enough pressure in touching the pad,
2. You have made more entries than the control panel will accept,
3. You have made an incorrect entry.

In addition to the entry signal tone, an audible signal will sound for approximately 2 seconds at the end of the cooking cycle.

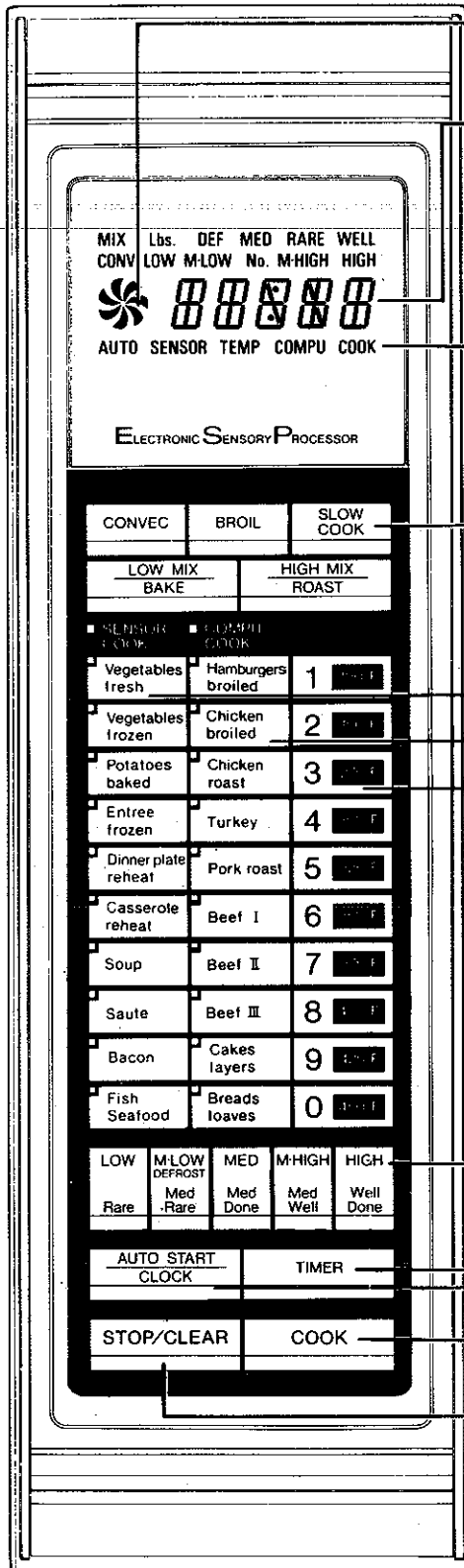

CONVECTION FAN SYMBOL

LIGHTED DIGITAL DISPLAY

Shows readout of cooking time, convection temperature, Sensor or CompuCook setting, cooking instruction or time of day.

INDICATORS

Indicator lights for Convection (CONV), Variable Cooking, Cook, Mix, food doneness (rare, med, well), pounds (Lbs.), number (No.), Sensor, Compu and Auto Start (AUTO).

COOKING FUNCTION PADS

Touch to select Convection, Mix, Broil or Slow Cook settings.

SENSOR COOK PADS

Touch to select Sensor Cook settings.

COMPU COOK PADS

Touch to select CompuCook settings.

NUMBER AND TEMPERATURE SELECTION (CONVECTION) PADS

Touch to enter cooking times, clock time or convection temperature.

VARIABLE COOKING CONTROL/FOOD DONE-NESS SETTING PADS

Touch to select microwave power setting. If not touched, HIGH is automatically selected.

Touch to select food doneness setting for CompuCook.

If not touched, Well Done is automatically selected.

TIMER PAD

Touch to set minute timer:

AUTO START/CLOCK PAD

Touch to set clock or auto start time.

COOK PAD

Touch to start oven.

STOP/CLEAR PAD

Touch to erase during programming.

Touch once to stop operation of oven during cooking; touch twice to cancel cooking program.

Figure 11-6. Microwave/Convection Oven Control Panel.



Basic operation, only will be presented here. For complete information, refer to the Operation Manual and Cook Book supplied for you by the oven manufacturer. It is suggested that you first practice operating the oven with a glass measuring cup full of water rather than food.

To Set the Clock

Set the clock as follows:

1. Touch the **AUTO START CLOCK** pad.
2. Enter the correct time of day by touching the numbers in sequence.
3. Touch the **AUTO START CLOCK** pad again. Time will be displayed with a colon between the hours and minutes.

Note

If power is interrupted, and then restored, 88:88 will flash on/off every second. Touch the **STOP/CLEAR** pad; 1:00 will appear. Proceed to set as above. When an incompatible clock time is entered, such as 13:61, "ERROR" will show in the readout. Touch **STOP/CLEAR** pad to erase.

Microwave Cooking

1. Make certain the metal turntable is seated and in place. The oven should not be used without the turntable in place, and it should never be restricted so that it cannot rotate.
2. Select the rate of cooking (or defrosting). There are five levels or settings for cooking: **HIGH, M-HIGH, MED, M-Low (Defrost)** and **LOW**. If you do not touch a setting on the control panel, the oven will automatically cook at **HIGH**.
3. Enter desired cooking time by touching numbers. One minute, thirty seconds will show on the display as 1.30.
4. Touch **COOK**.

Microwave Utensils

The ideal material for a microwave utensil is transparent to microwaves; it allows energy to pass through the container and heat the food. Many ordinary household items, such as paper, plastic or wooden bowls may be used to warm foods to serving temperature.

When a utensil is used for cooking, it must also be able to withstand contact with very hot food or boiling liquid. Manufacturers are now marketing dual-purpose, heat resistant paper and plastic utensils which can be used in both microwave and conventional ovens; in addition, many traditional cooking containers are suitable for microwaving.

Usable metal includes aluminum foil for shielding, small skewers, and shallow foil convenience food trays. The amount of metal used must be in proportion to the volume of food; foil trays should be two-thirds to three-fourths full.

Keep metal at least 1 inch away from oven walls to prevent arcing. Deep trays and metal pans are unsuitable because they reflect too much energy away from food. Foil-lined cartons shield food completely, so it does not heat at all.

Convection Cooking

During convection heating, hot air is circulated throughout the oven cavity to brown and crisp foods quickly and evenly.

1. The oven should not be used without the metal turntable in place and it should never be restricted so that it cannot rotate. You may remove the turntable when preheating the oven or when preparing food to be cooked directly on the turntable; cookies, for example.
2. Preheating may be accomplished by the following:
 - a. Touch the **CONVECTION** pad.
 - b. Touch the desired pre-heating temperature.
 - c. Touch the **COOK** pad. Convection fan symbol will flash on and off. When the oven reaches the programmed temperature, the convection fan symbol will stop flashing and begin rotating with an audible signal sounding four times. Preheat temperature will be held for 15 minutes. After this period the audible signal will again sound four times and the oven will turn off.
3. **Convection – Only** cooking may be performed as follows:
 - a. Enter desired cooking time by touching numbers. Twelve minutes will show on the display as 12.00.



- b. Touch **CONVECTION** pad.
- c. Enter desired temperature.
- d. Touch cook pad. **COOK** indicator will light and Convection fan symbol will rotate. When the timer reaches zero (0), **COOK** and **CONV** indicators and the convection fan symbol will go out. An audible signal will sound and the time of day will reappear on the display. You may check the oven temperature setting, while cooking, by touching the **CONVECTION** pad.

Convection Utensils

Microwave-only paper and plastic products should not be used for combination cooking or placed in the oven while it is still hot from convection cooking.

Be sure to use hot pads when handling utensils. They become hot from convection and combination cooking.

The metal carousel is a utensil itself: a drip pan under the broiling trivet during roasting and broiling, or a baking sheet for breads and cookies.

Baking rack serves as a shelf for two-level cooking, such as layer cakes or cookies. Use if for convection and combination cooking, not for microwaving alone.

Metal and aluminum foil pans are safe for combination as well as convection cooking. During the convection cycle heat transferred from the pan cooks the bottom and sides of food. During the microwave cycle, energy penetrates from the top.

Oven glass is excellent for convection, combination and microwave cooking. Stoneware and pottery utensils designed for use in ovens may be used if they are also microwave-safe.

Ovenable paper is designed for use in both microwave and conventional ovens up to 400°, so it is also suitable for convection or combination cooking.

Mountz Power Wrench

Usage described in Section VIII.

Konstant Hot Water Dispenser

Operated from 120V. ac (shoreline or power generator) to provide instant hot water.

Winterizing instructions are provided in Section V.

Kool-O-Matic Ventilation Fan

This 12 volt dc power ventilator has the capacity to move a large volume of air.

In many low humidity regions it will eliminate the need for operating air conditioning units.

Operation

Remove the magnetically attached fabric cover and open inlet dampers.

Be sure windows are open to provide proper air flow cooling and ventilation.

A heat-cool thermostat is located near the Kool-O-Matic fan. It also serves the area LPG furnace and chassis heater. In order to activate the fan, the selector switch (at the bottom) must be moved to **COOL** and the temperature lever set so the fan will operate. The fan will then start automatically whenever the temperature rises above the desired level.

Redi-Line Motor Generator

The motor-generator unit is an ac-generator that is driven by a 12 volt dc motor to provide the isolated 120 volts ac for the ice-maker, drapes, and one kitchen receptacle if desired. The motor-generator operates automatically, on demand, whenever the external control circuit to the respective appliance is completed and the ignition switch is on. A resettable 18 A. circuit breaker is provided on the receptacle panel.

Auxiliary Air Compressor

This unit provides a quick source of air so there is no need to wait for pressure to build up after starting engine; you just drive right off! It can be used to operate air tools and accessories without starting the coach engine. It also serves as a standby unit in the rare case of a malfunction in the engine driven air compressor system.

The compressor and starting relay are located in an outside compartment while the 12 volt switch to operate the relay is in an **ACCESSORY** position



on the dash.

Operation

The compressor operates from 120 volt ac power so the coach must be plugged into shore power or the generator must be running. Press dash switch (in **ACCESSORY** position) ON.

For intermittent use, enough air will be supplied by the luggage compartment. If, however, it is to be used for an extended period, such as to power air tools, it is suggested that the luggage compartment door be opened.

Maintenance

No lubrication is required for the life of the unit.

The air inlet filters should be inspected once or twice a year. The black plastic air inlet covers can be removed by turning counter-clockwise. This will reveal the felt filters. If there is evidence of dirt on filters and covers they may be washed in a solvent and air dried.

CORIAN Counter Tops

Even stubborn stains — such as grape or beet juices — wipe off with a damp cloth and household cleanser. Because CORIAN is solid all the way through, it cannot be harmed by abrasive cleansers and normal household cleaners.

CORIAN is strong and tough, but slicing on it with knives can cause scratches. Use a cutting board.

While CORIAN does provide an extra measure of protection (better than ordinary countertops), it is **not** recommended as a hot pad. Do not place hot pots and pans directly on your CORIAN countertop.

Since it's a solid material with color and pattern all the way through, unusual damage such as cigarette burns, scratches, or other surface abuse can usually be removed using ordinary household cleansers or fine sandpaper. If the stain persists, or if the scratch is particularly deep, first use a medium sandpaper (120 or 240 grit) then fine sandpaper (320 or 400 grit) followed by circular motion buffing with a scotch Brite pad to match the gloss of adjacent surfaces. Household cleanser, steel wool or Du Pont No. 7 polishing compound can also be used if higher gloss levels are needed.

Caution

Certain chemicals found in the home — such as paint removers, paint brush cleaners, acid drain cleaners and certain brands of nail polish and polish removers — can harm CORIAN if left in contact even for short periods of time. These materials should be wiped away promptly and flushed with water. Depending on time of exposure, surface damage caused by these materials can sometimes extend too deeply for practical repairs.

Water System Air Accumulator With Diaphragm

An accumulator in the water system smooths out the water flow, eliminates water hammer, and pulsations from the water pump.

Having no diaphragm, the present accumulator can become water-logged, lose its effectiveness and require frequent re-pressurizing.

The WX101 incorporates a butyl diaphragm with the air side (top) being pre-charged to 20 psi. If this is accidentally lost, the accumulator may be re-charged to 20-25 psi through the Schrader valve on top.