



BLUE BIRD

# WANDERLODGE



# ELECTRICAL SYSTEM BOOKLET #3

46	0010405#1	D. WRG. STOP LIGHT M11
47	0010405#2	D. WRG. STOP LIGHT M11
48	0010397#1	D. WRG. STOP LIGHT DDEC
49	0010397#2	D. WRG. STOP LIGHT DDEC
50	0002329	D. WRG. DIRECTIONAL LIGHTS
51	0000240	D. WRG. BACK UP LIGHT CIRCUIT
52	0005561	D. WRG. REAR DRIVING LIGHTS
53	0005587	D. WRG. LUGGAGE COMPARTMENT LIGHTS
54	1995497	D. WRG. DAY TIME RUNNING LIGHTS, PARK CIRCUIT M11
55	1999853	D. WRG. DAY TIME RUNNING LIGHTS
56	1975572	D. WRG. WIPERS
57	1991561	D. WRG. MIRROR SWITCH CIRCUIT
58	1996727	D. WRG. THERMOKING A / C
59	1991595	D. WRG. ROOF HATCH
60	1995513	SWITCH ASSEMBLY, TURN SIGNAL
61	1153655	FILTER FUEL / WATER SEPARATOR RACOR
62	1959782	D. WRG. INTERCONNECT ELECTRICAL SYSTEM Q4 BODY
63	XXXXXX	INTERCONNECT LOCATIONS Q4 BODY
63A	XXXXXX	LTC DASH ELECTRO LUMINESCENT LIGHTING

HC1 HB1

(A)

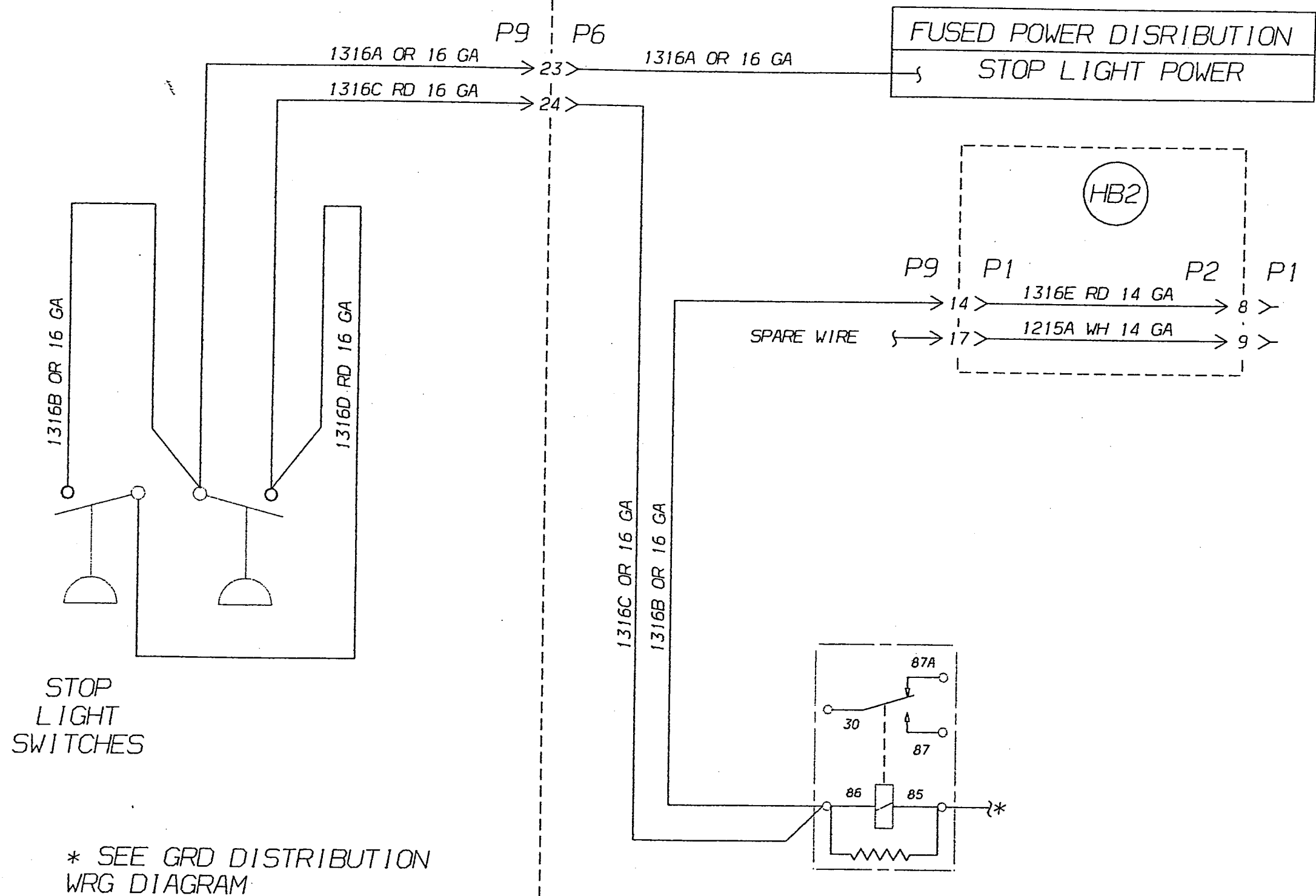

STOP LIGHT SWITCHES

\* SEE GRD DISTRIBUTION WRG DIAGRAM

CRUISE OVERRIDE

D.WRG. STOP LIGHT MM11 0010405 #1

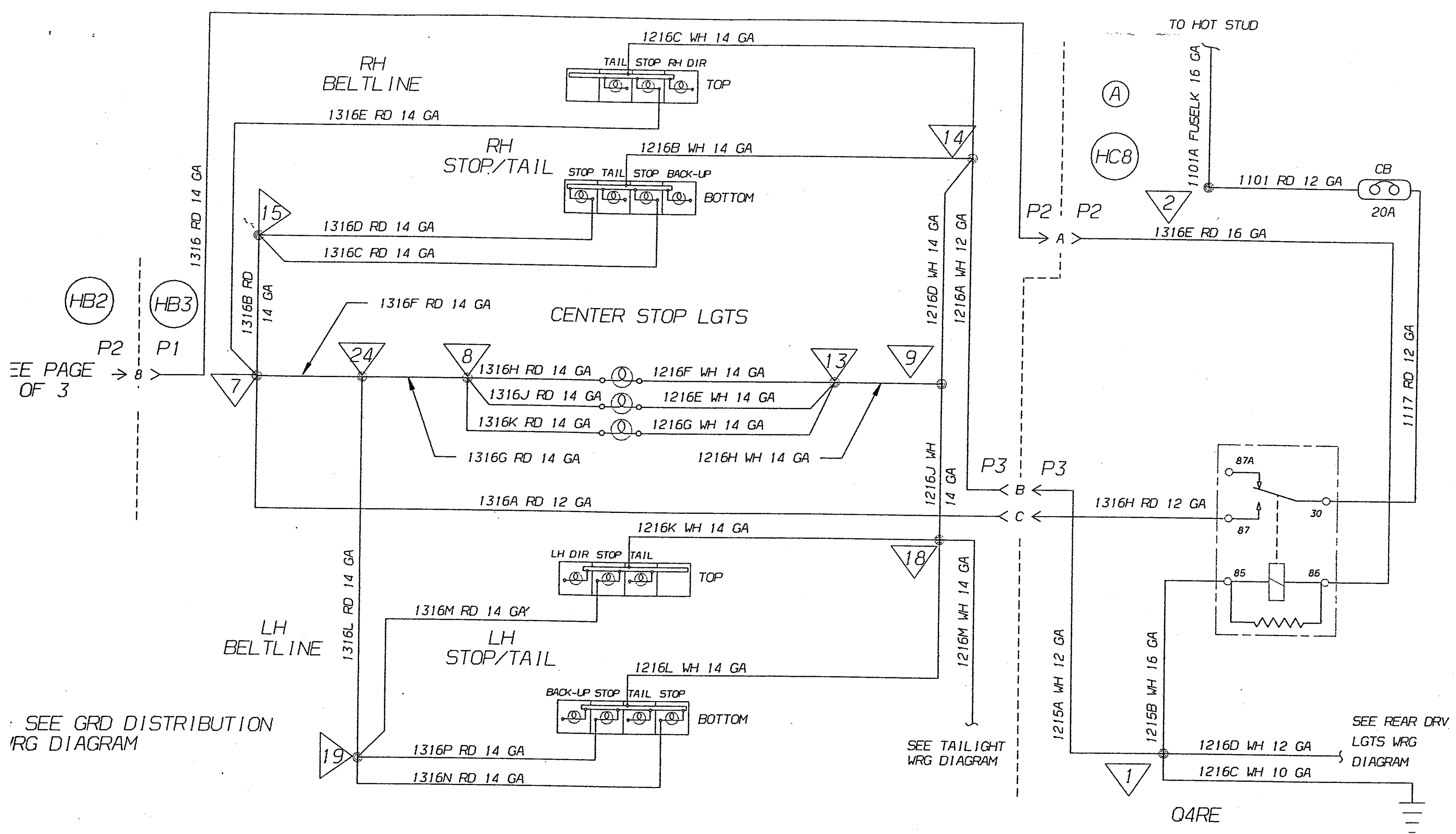

SEE PAGE OF 3

SEE GRD DISTRIBUTION WRG DIAGRAM

SEE TAILIGHT WRG DIAGRAM

SEE REAR DRV LGTS WRG DIAGRAM

D. WRG. STOP LIGHTS M11 0010405 #2

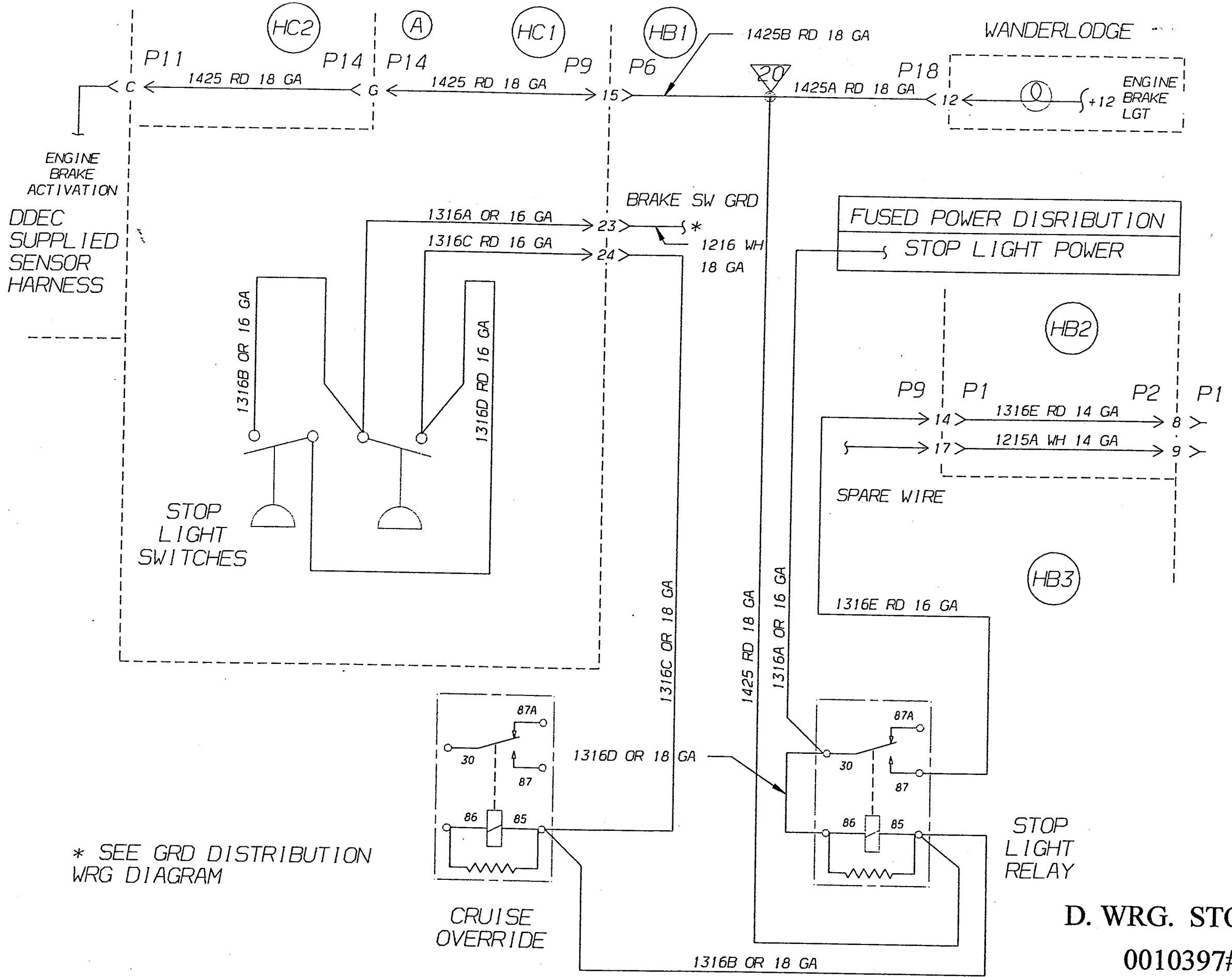

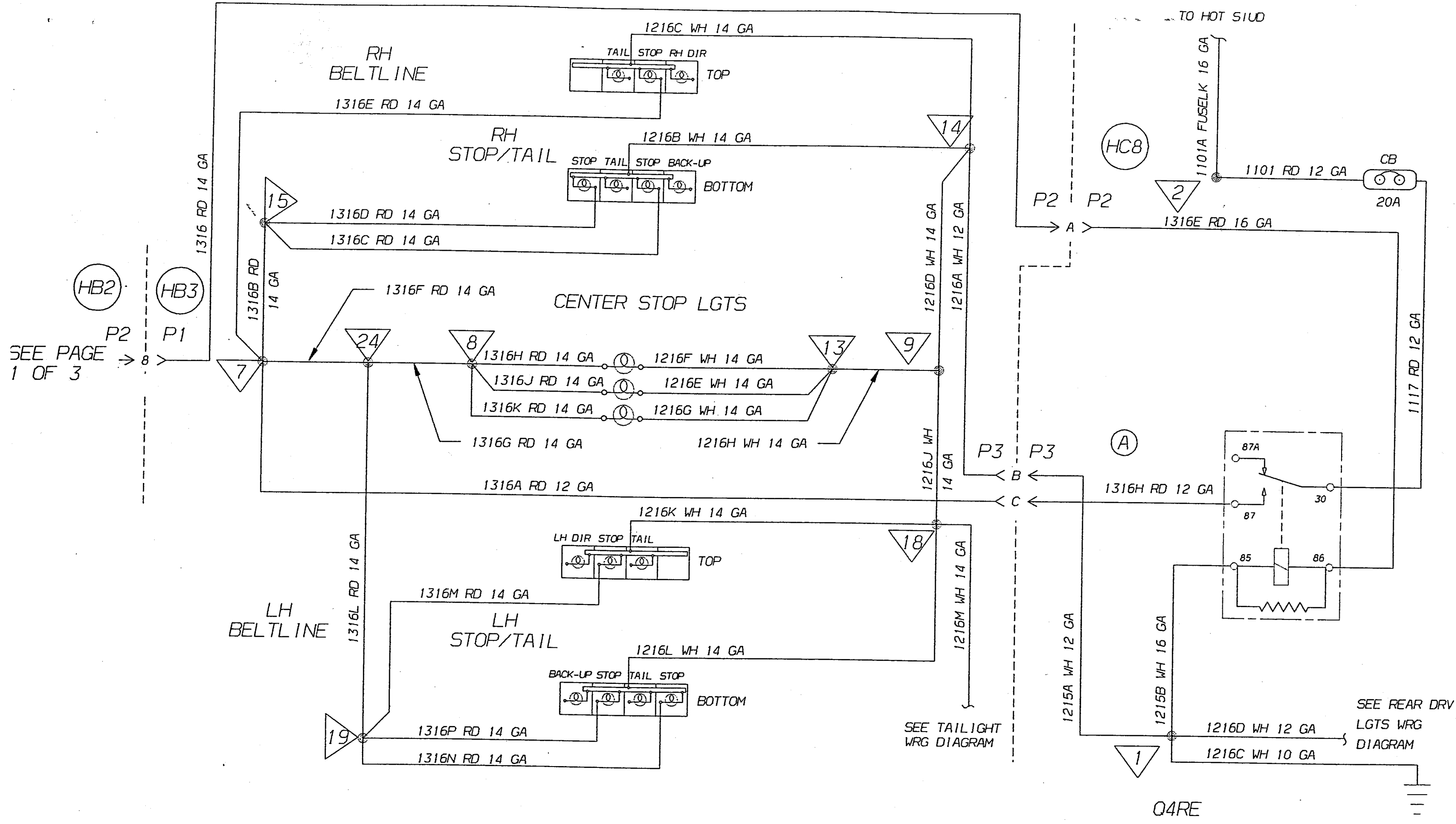

SEE PAGE 1 OF 3 →

D. WRG. STOP LIGHTS DDEC 0010397 #2M



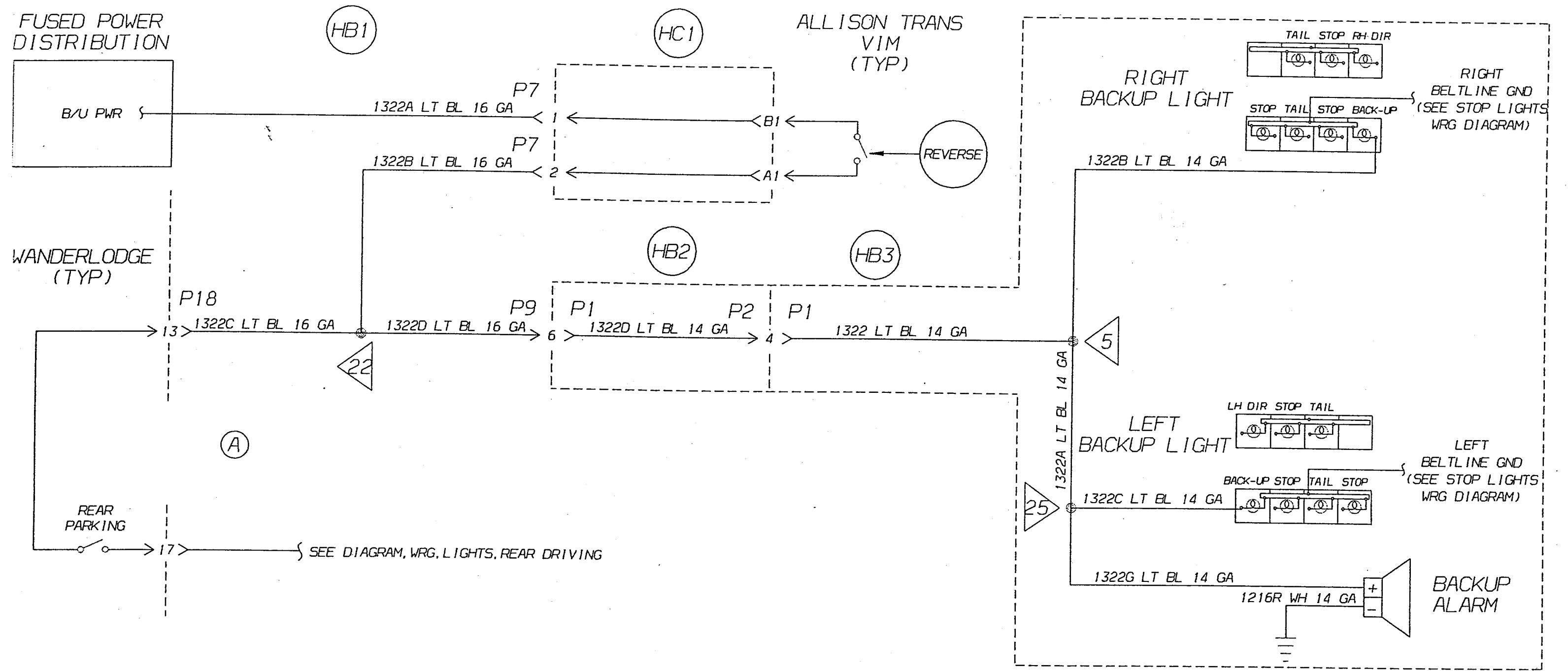

D. WRG. BACK UP CIRCUIT 0000240



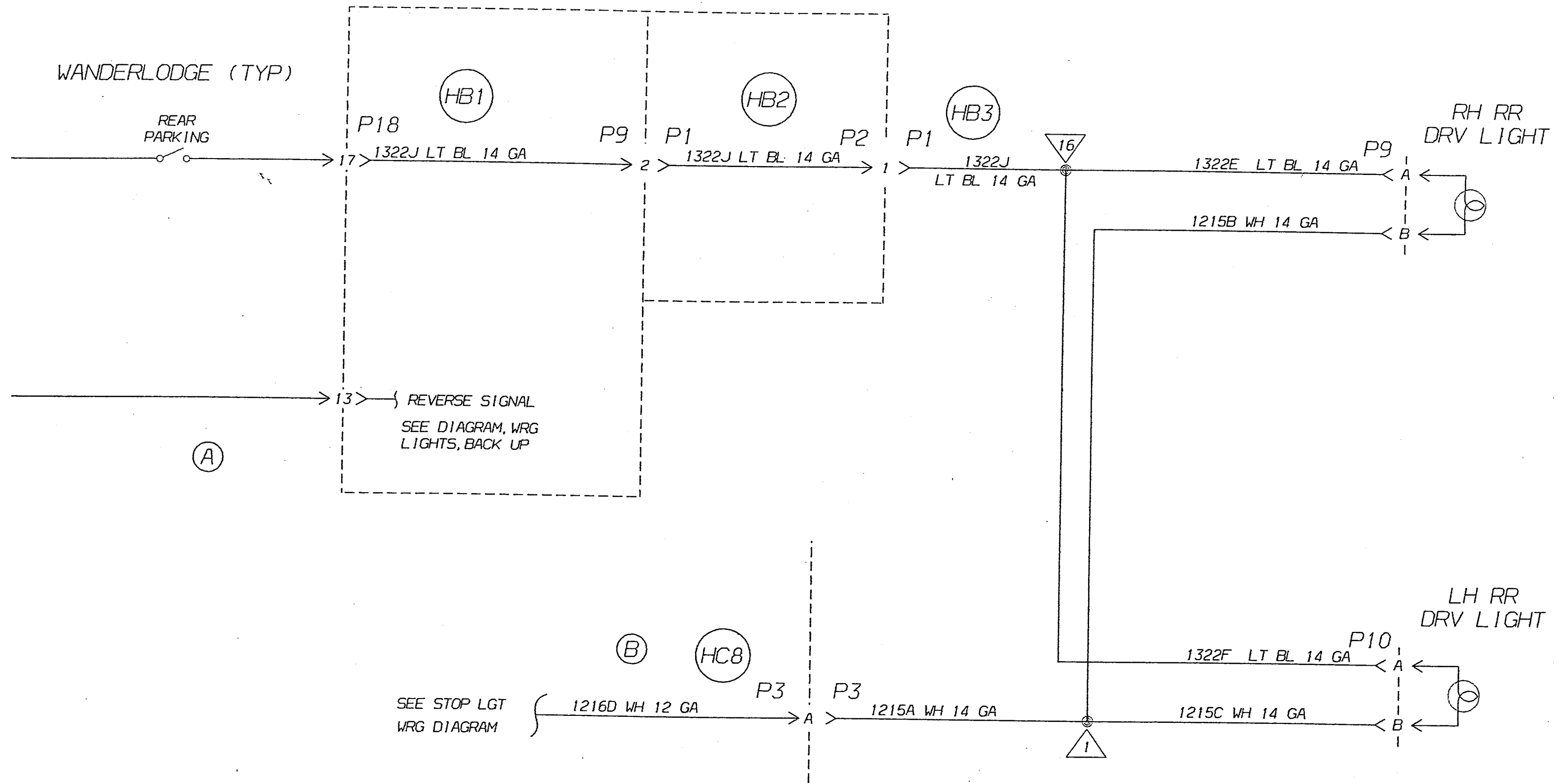

D. WRG. REAR DRIVING LIGHTS 0005561M REV.

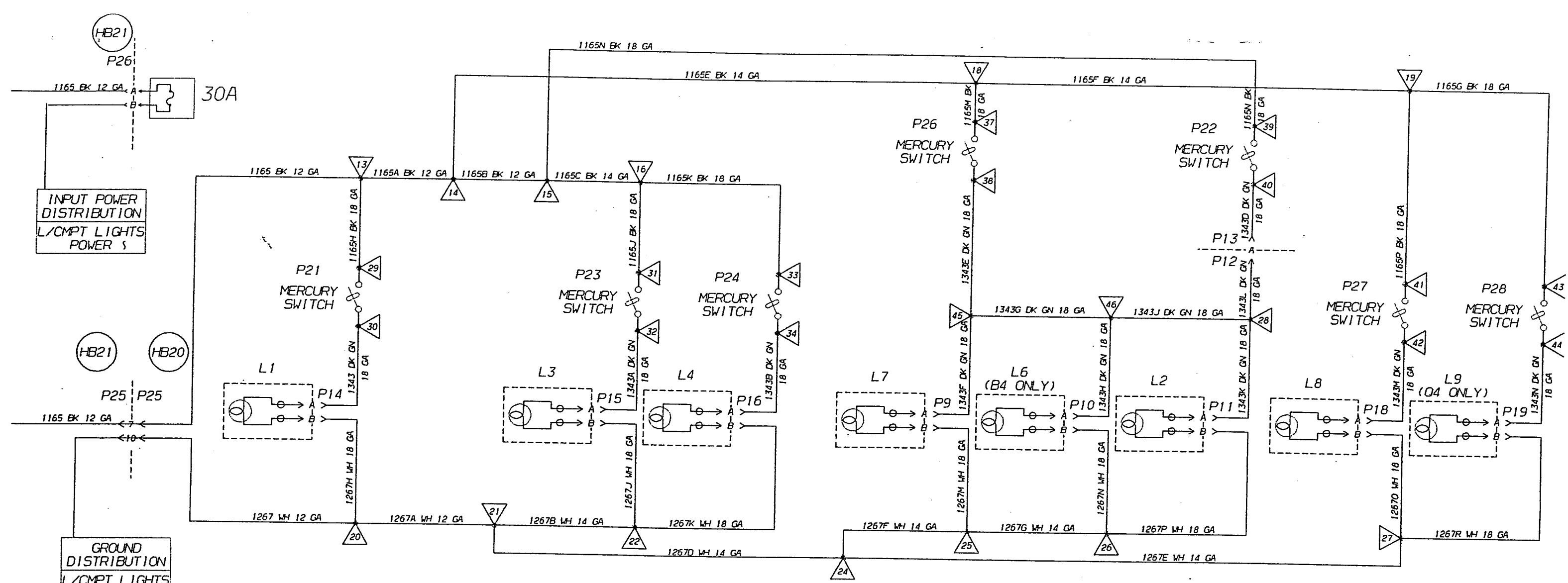

LIGHT ASSEMBLY IDENTIFICATION DIAGRAM

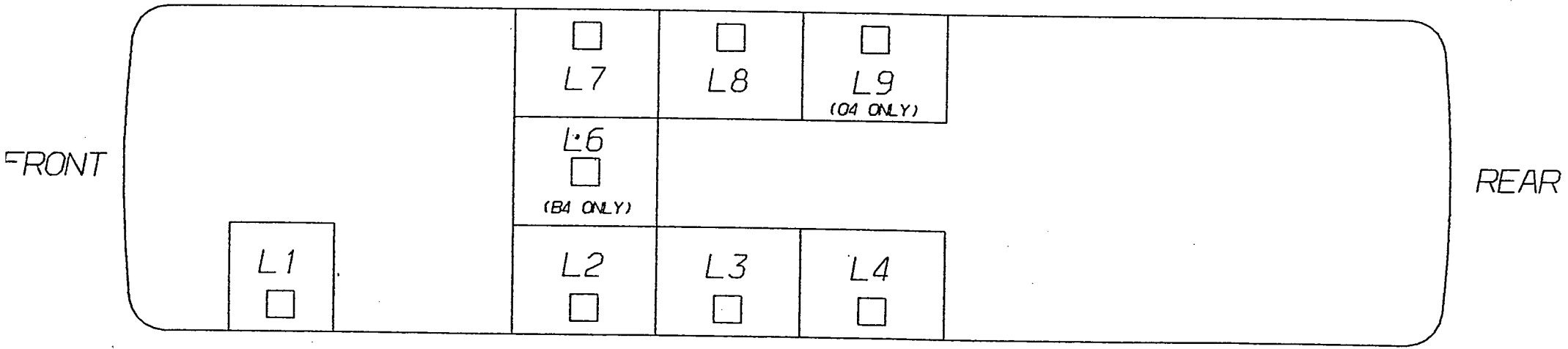

D. WRG. LUGGAGE COMP. 0005587M REV.

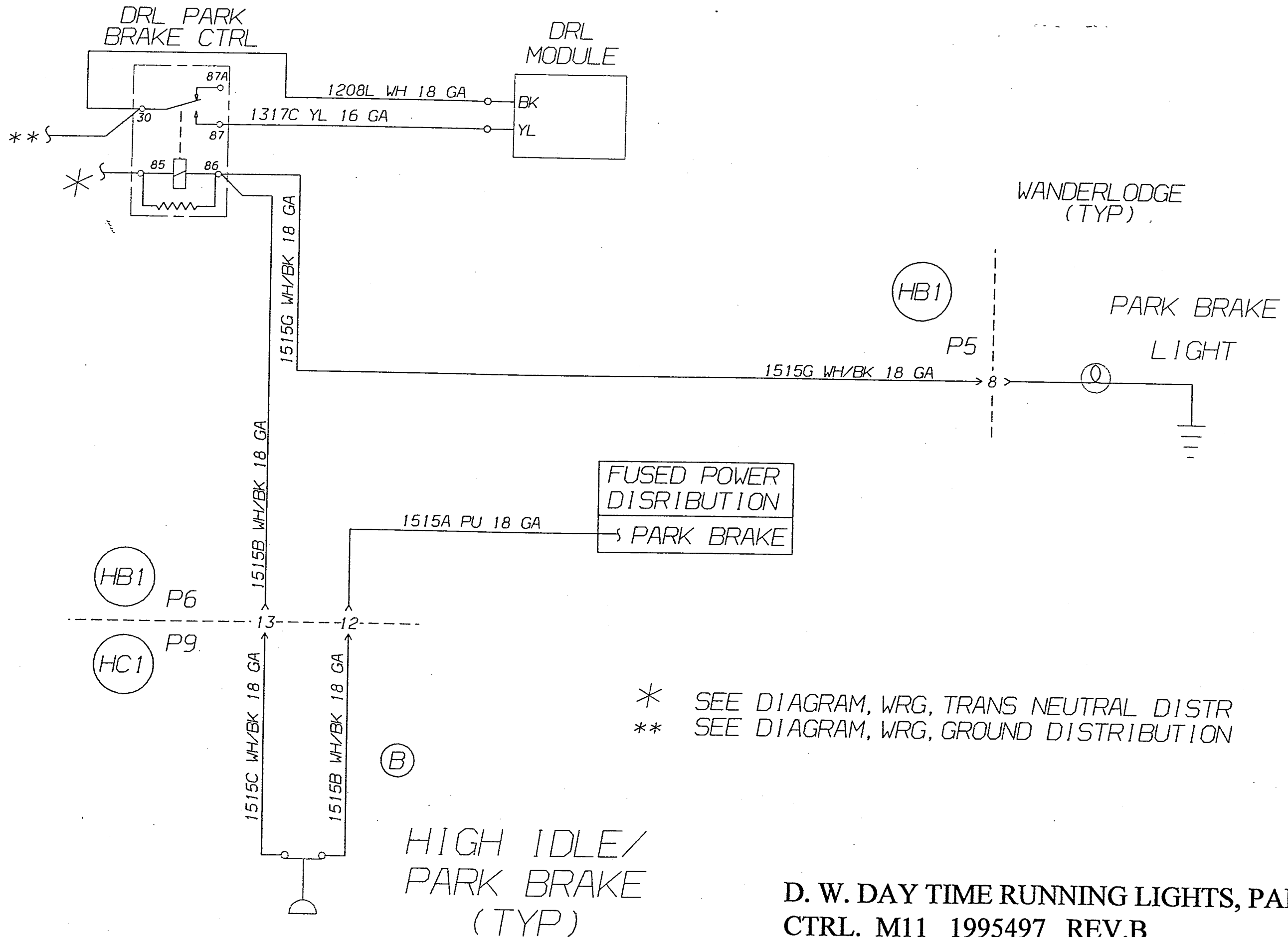

D. W. DAY TIME RUNNING LIGHTS, PARK CTRL. M11 1995497 REV.B

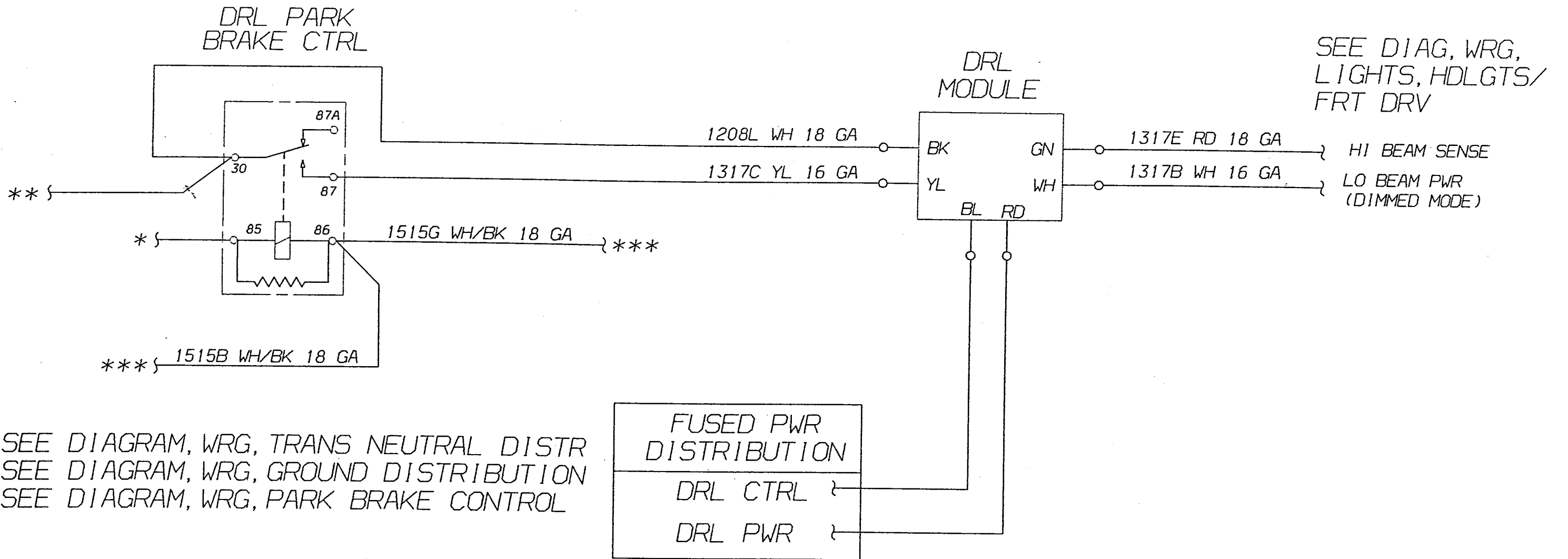

D. W. DAY TIME RUNNING LIGHTS 1999853

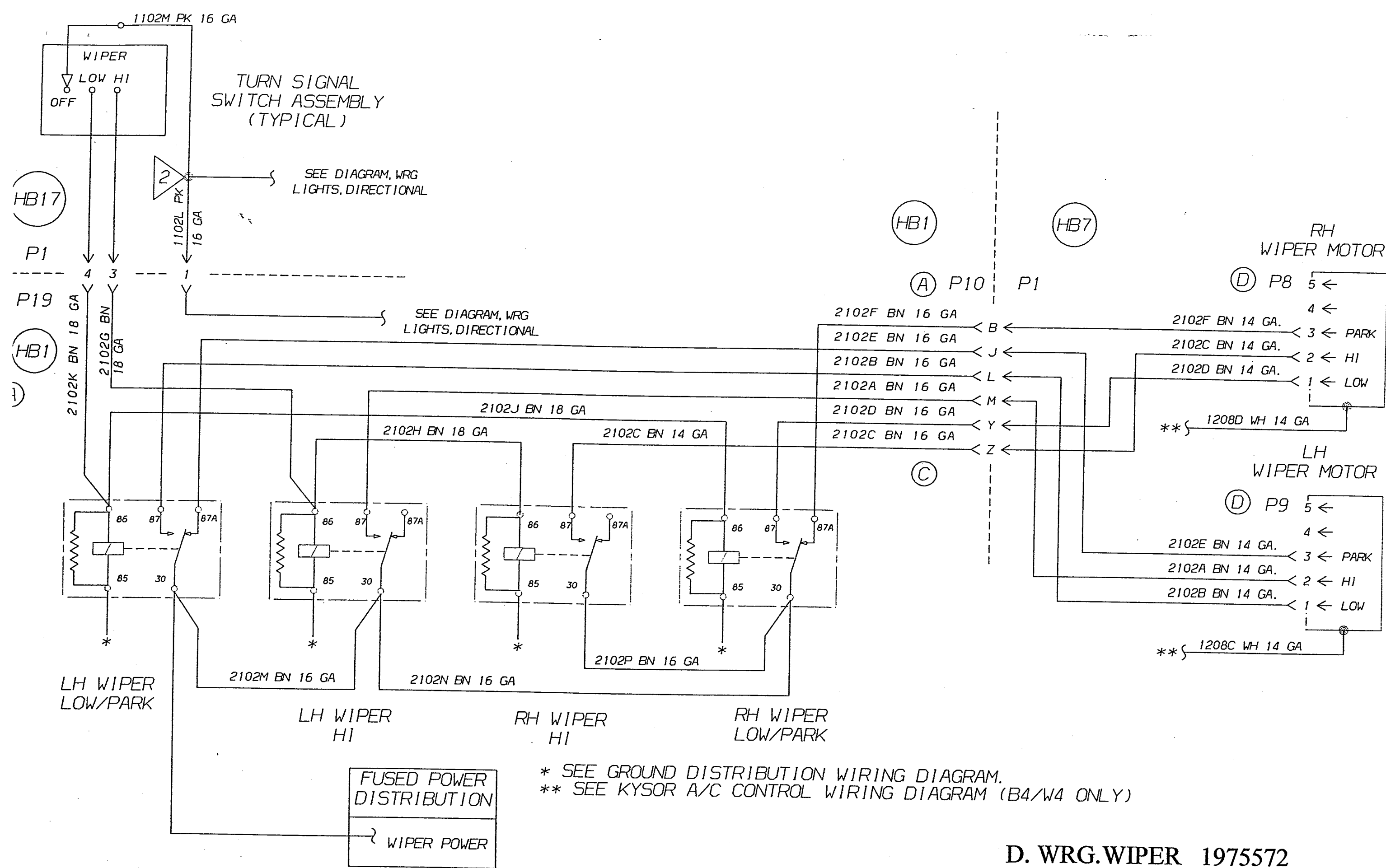

D. WRG.WIPER 1975572

WANDERLODGE  
(TYP)

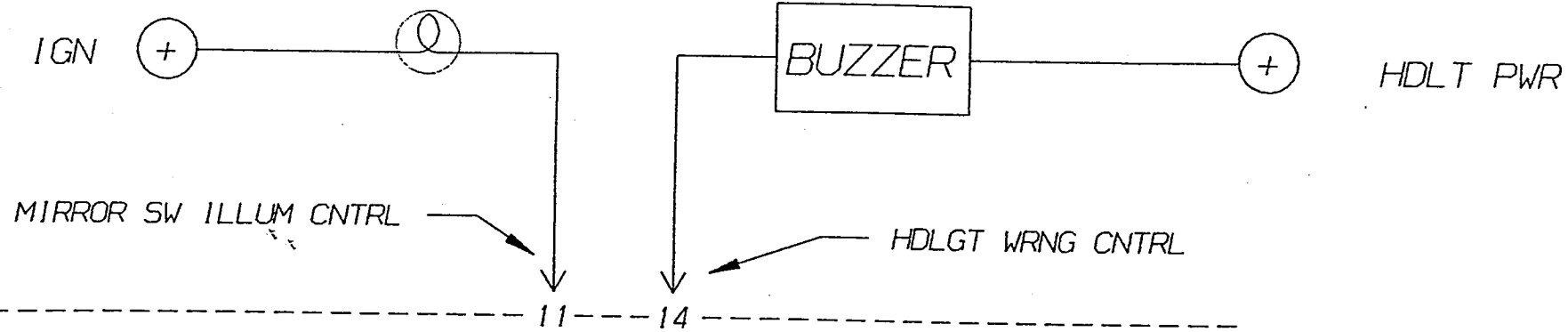

HB1  
P18  
A

\* SEE GROUND DISTRIBUTION

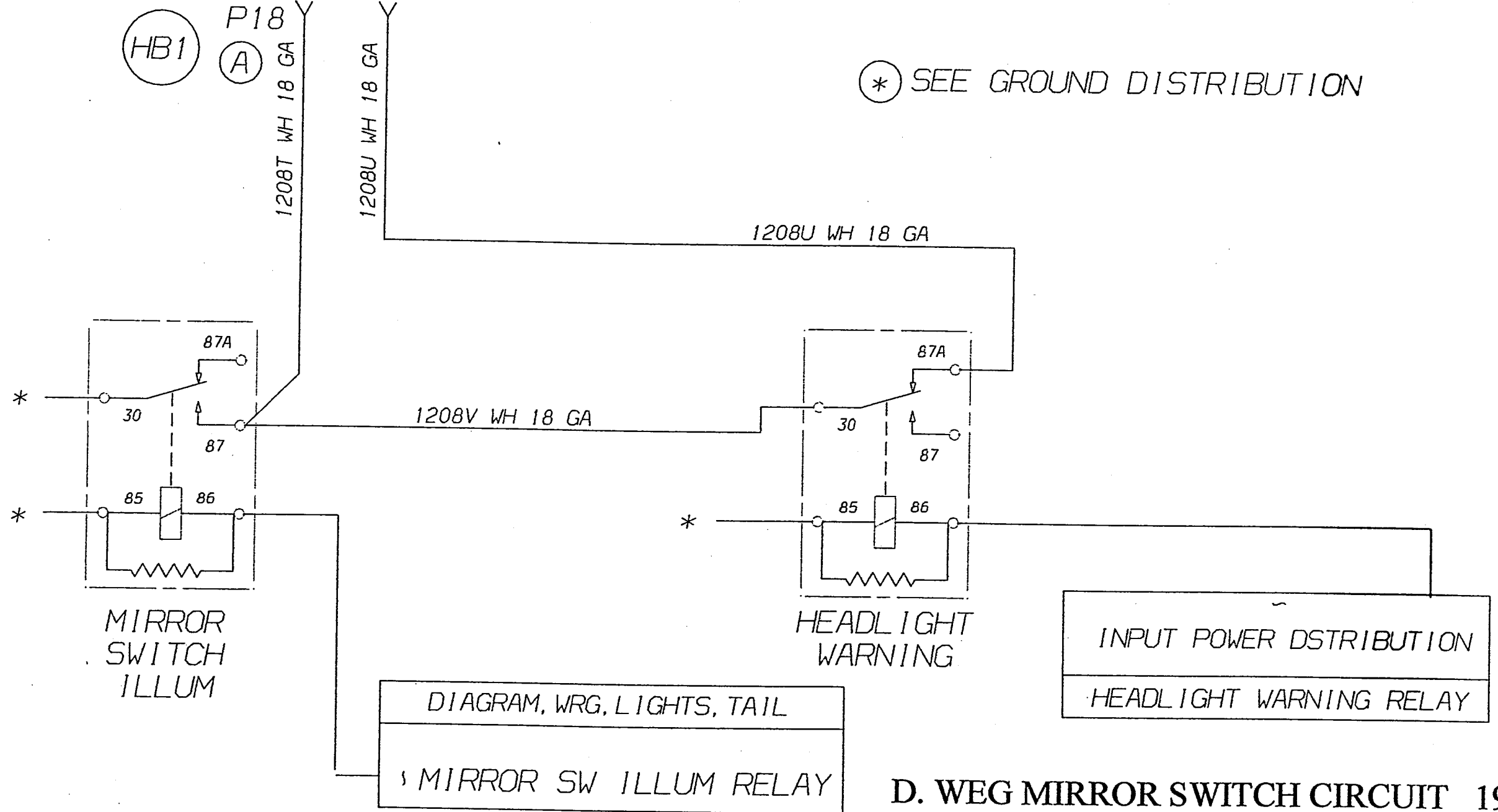

MIRROR  
SW ILLUM  
ILLUM

HEADLIGHT  
WARNING

INPUT POWER DSTRIBUTION  
HEADLIGHT WARNING RELAY

DIAGRAM, WRG, LIGHTS, TAIL  
MIRROR SW ILLUM RELAY

D. WEG MIRROR SWITCH CIRCUIT 1991561

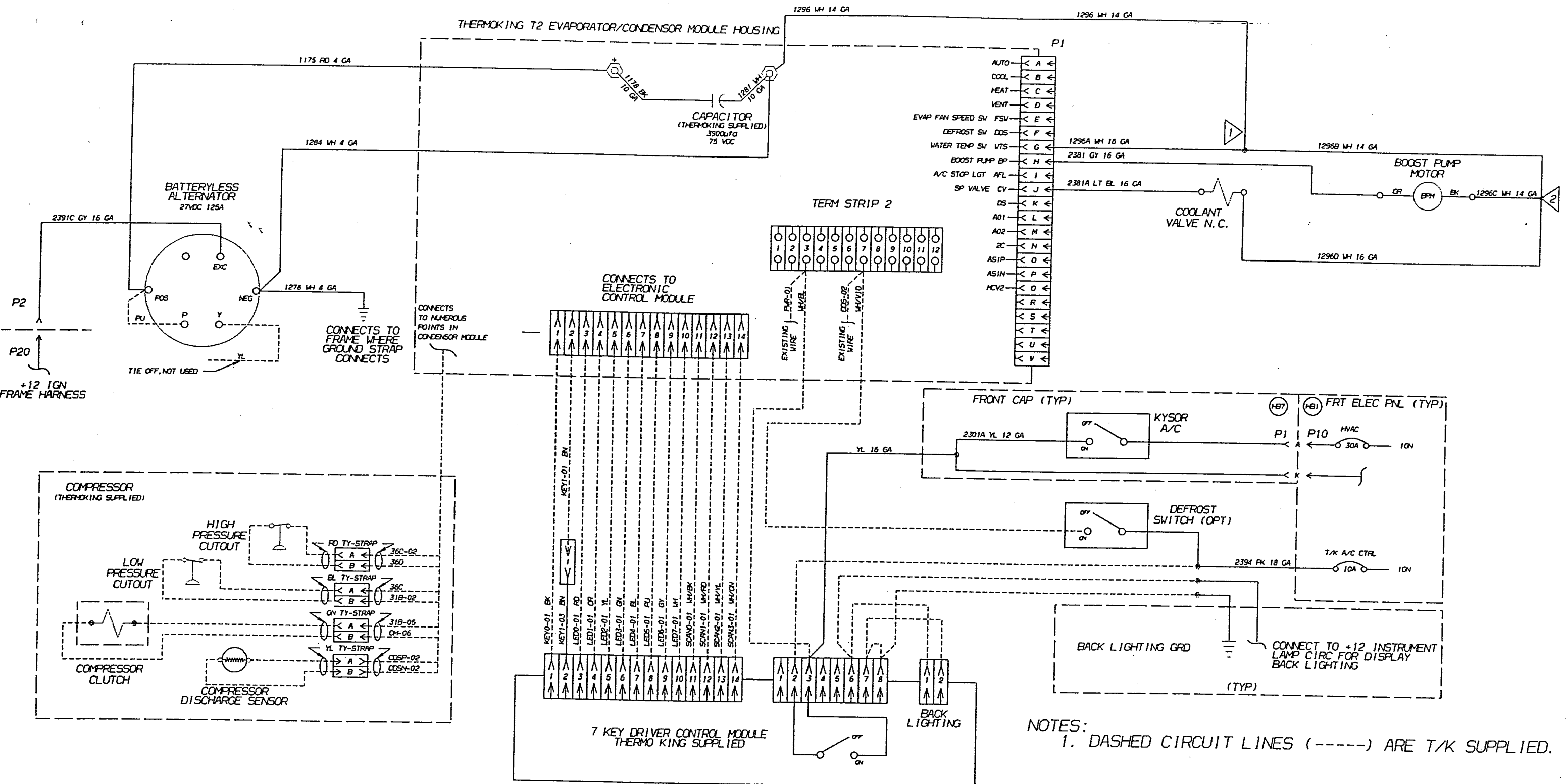

D. W. THERMOKING A/C 1996727

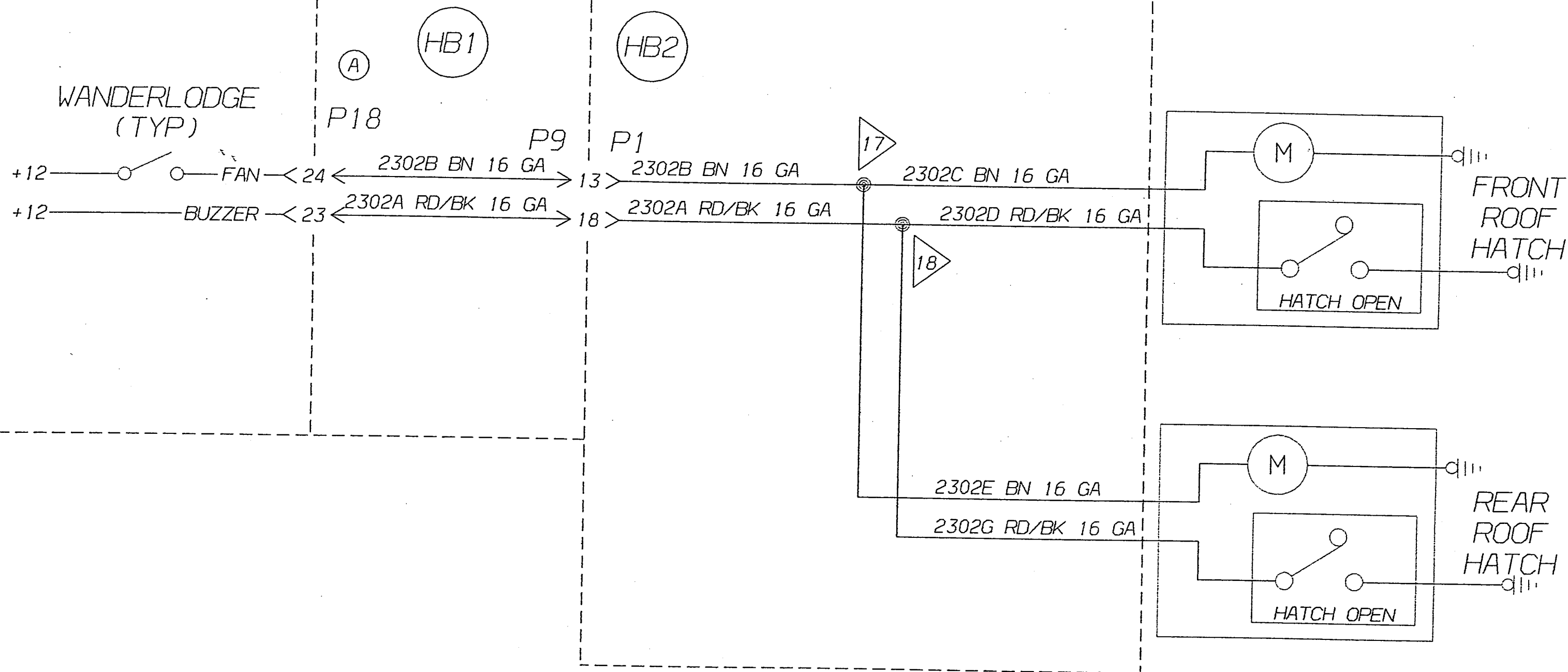

D.W. ROOF HATCH 1991595M REV. A



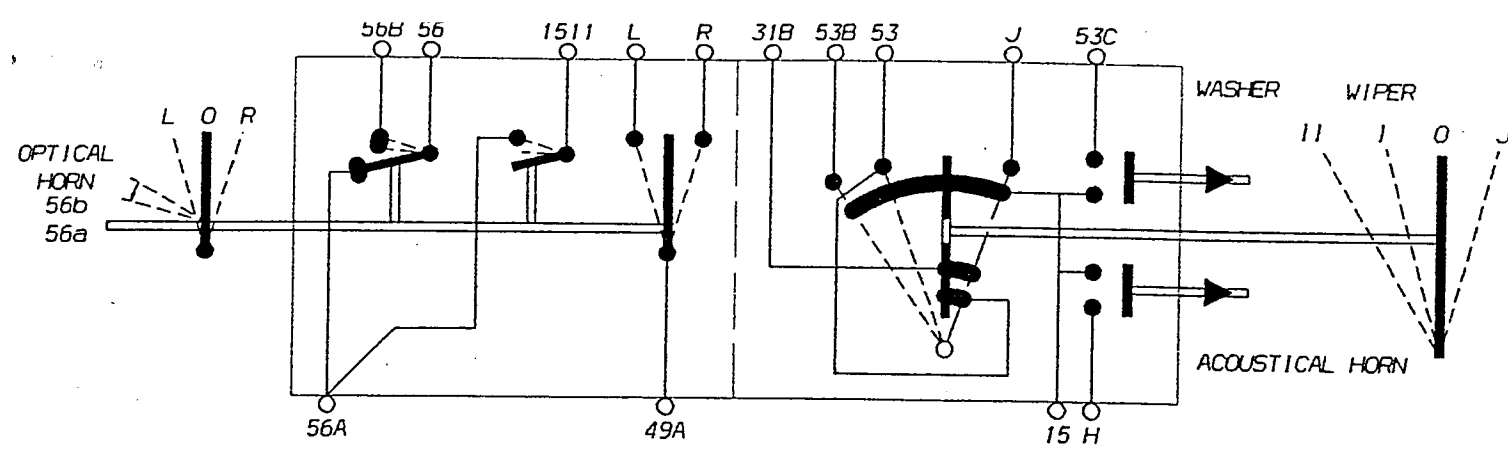

- 1995513 SWITCH ASSY, TURN SIGNAL, SELF CANCELLING WL
- 1399195 SWITCH, DIRECTIONAL, SLF CNCL, E-003-009
- 1218486 TUBING, HEAT SHRINK, SEALING, BLACK, 3/8 DIA
- 1985167 HARNESS, WRG, STEERING COLUMN W4RE

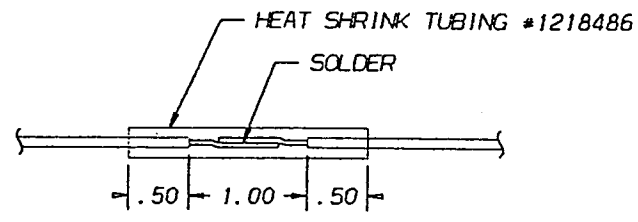
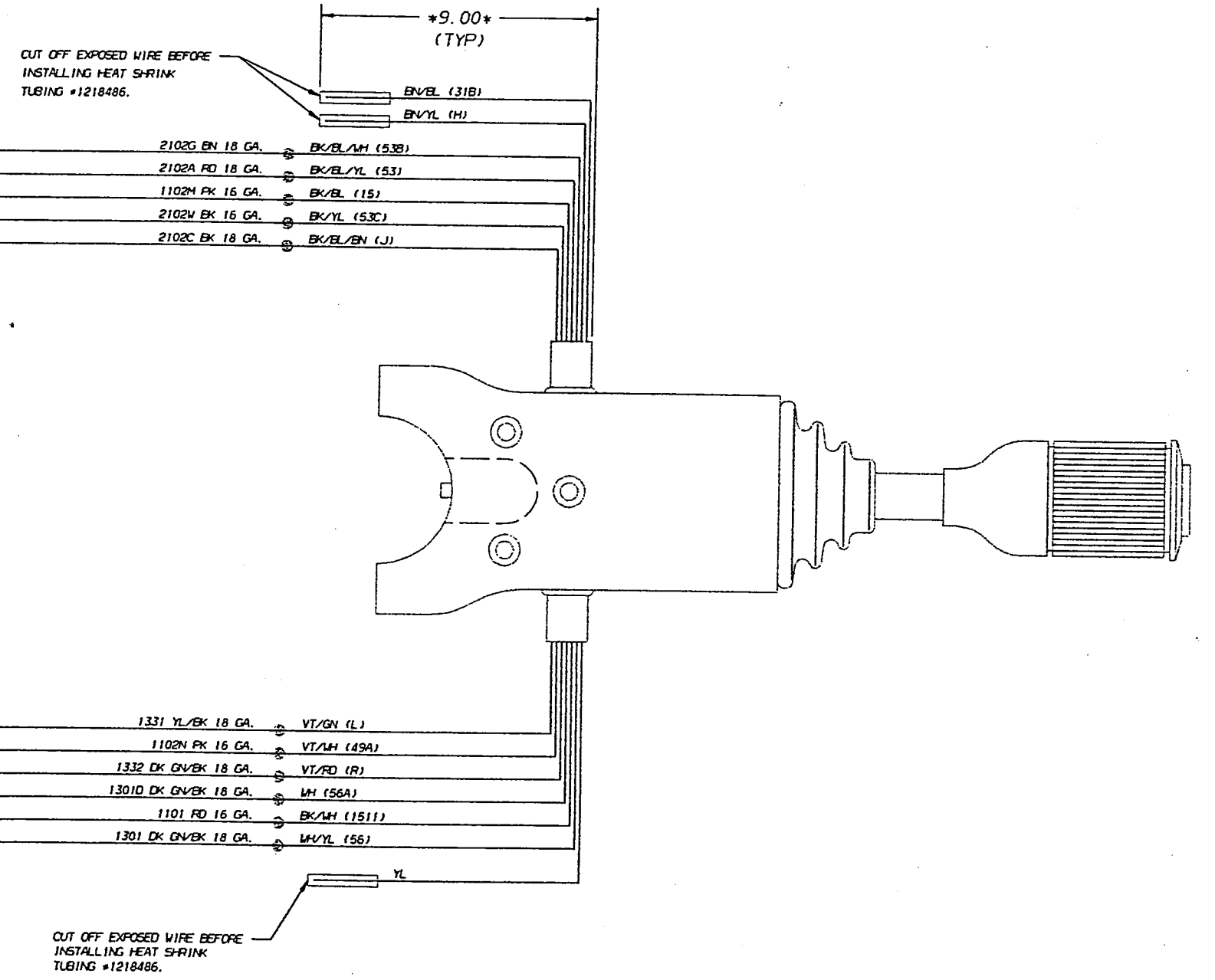

SPLICE DETAIL.

SWITCH ASSY. TURN SIGNAL 1995513

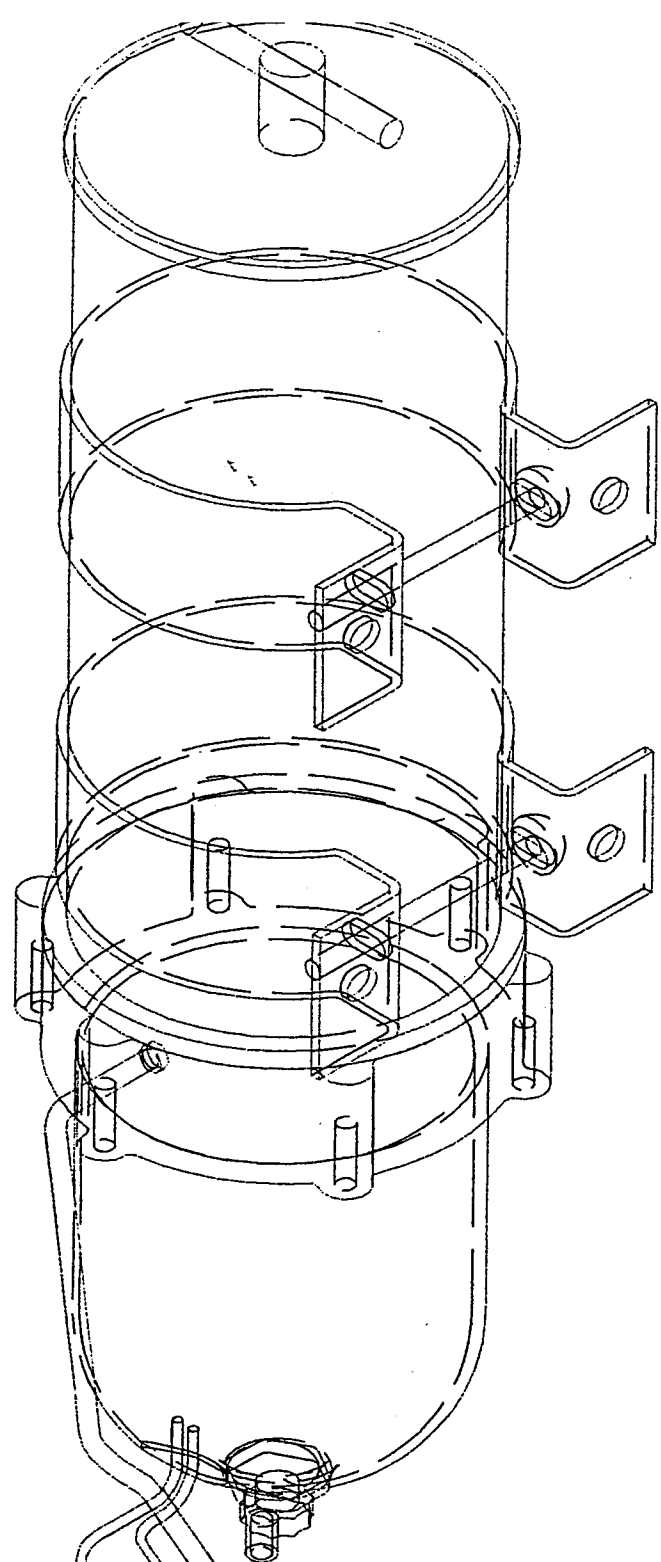

FILTER: 30 MICRON, RED RACOR

CONNECTOR DETAIL  
 12015798 W/SOCKET 12124580 (D)

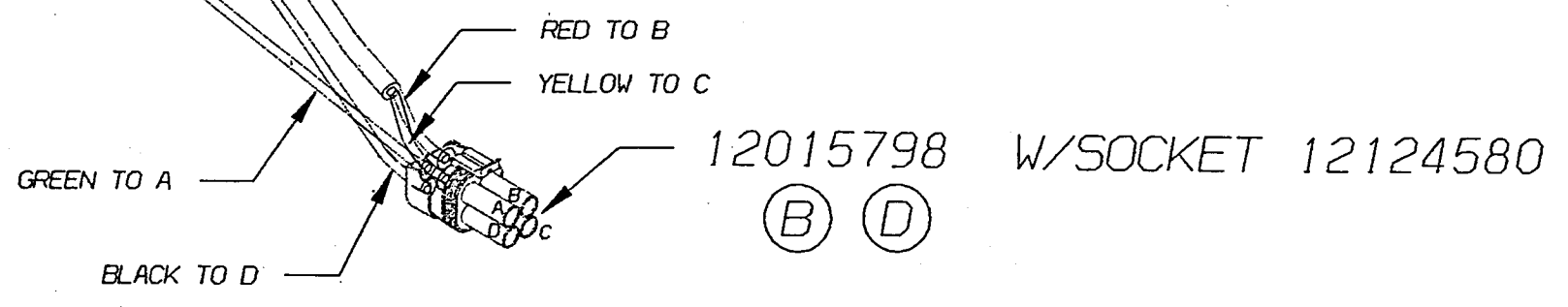
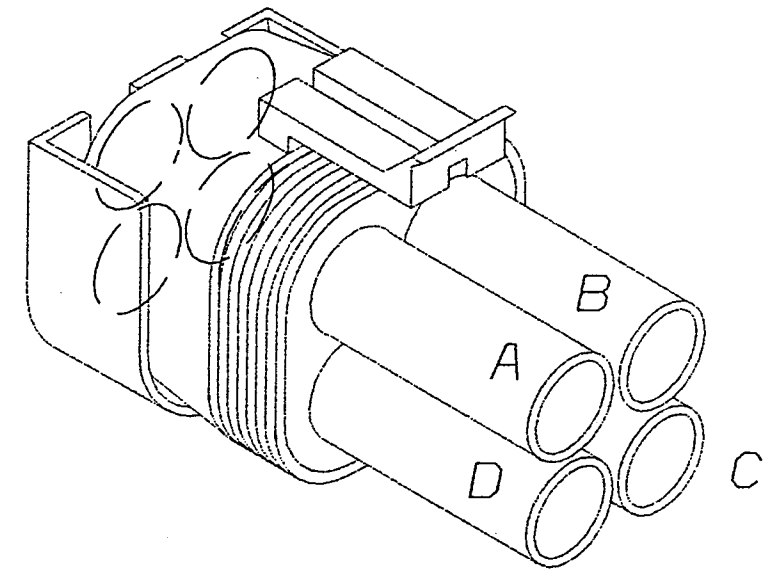

FILTER FUEL / WATER SEPARATOR  
 RACOR 1153655M

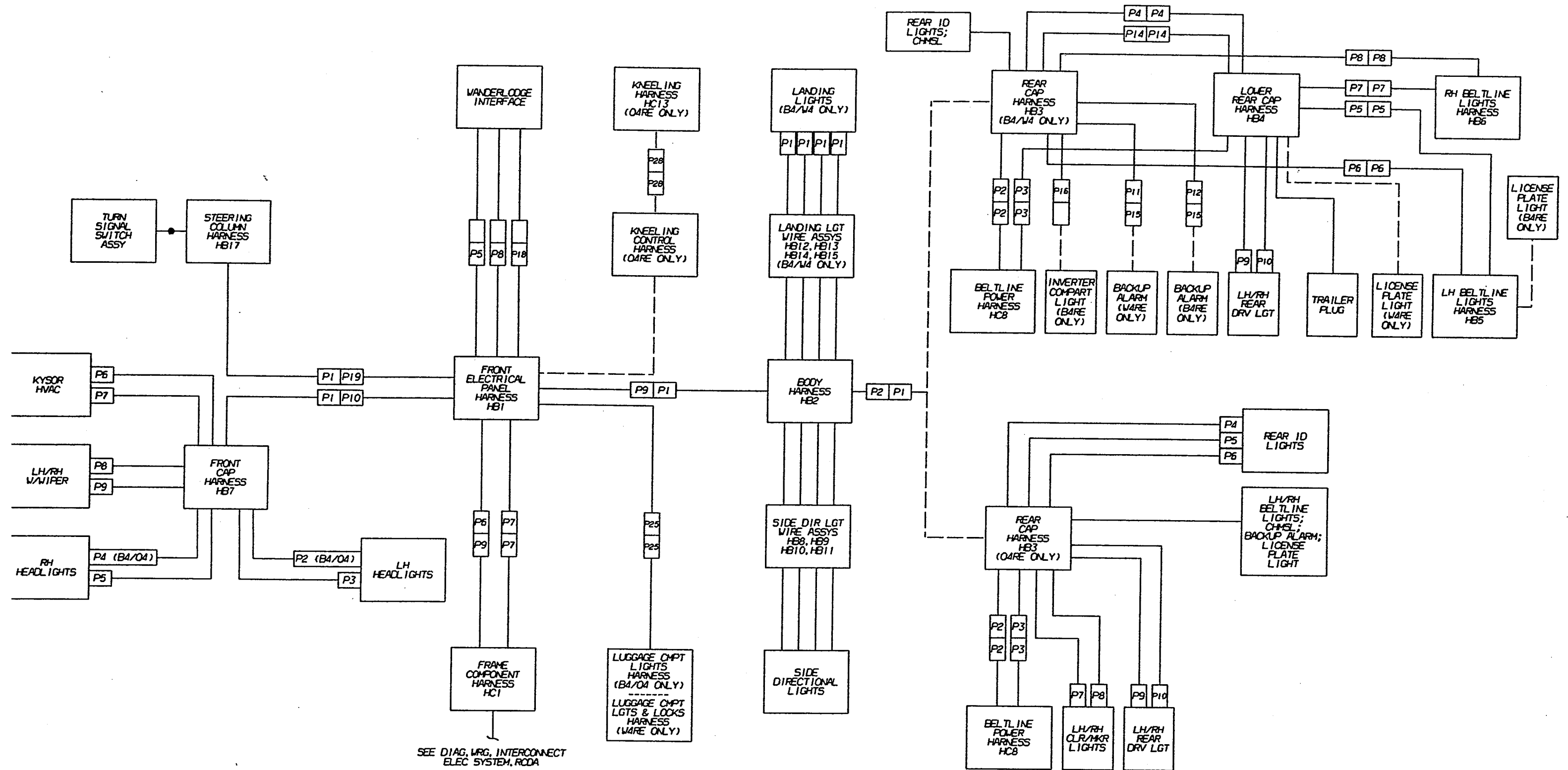

## INTERCONNECT LOCATIONS Q4 BODY

#	DESCRIPTION	LOCATION
1	P6 TO KYSOR HVAC	UPPER DASH
2	P7 TO KYSOR HVAC	UPPER DASH
3	P8 TO WIPER	AT THE WIPER MOTOR
4	P9 TO WIPER	AT THE WIPER MOTOR
5	P4 TO HEAD LIGHTS	NO CONNECTOR USED, CIRCUIT RUNS TO THE HEAD LIGHTS
6	P5 TO HEAD LIGHTS	NO CONNECTOR USED, CIRCUIT RUNS TO THE HEAD LIGHTS
7	P1 TO P19	SIDE ELECTRICAL PANEL, LEFT SIDE, REF. PICTURE B. P.11
8	P1 TO P10	SIDE ELECTRICAL PANEL, LEFT SIDE, REF. PICTURE B. P.11
9	P2 TO HEAD LIGHTS	NO CONNECTOR USED, CIRCUIT RUNS TO THE HEAD LIGHTS
10	P3 TO HEAD LIGHTS	NO CONNECTOR USED, CIRCUIT RUNS TO THE HEAD LIGHTS
11	P5 TO W. INTERFACE	SIDE ELECTRICAL PANEL, LEFT SIDE, REF. PICTURE B. P.10
12	P8 TO W. INTERFACE	SIDE ELECTRICAL PANEL, LEFT SIDE, REF. PICTURE B. P.10
13	P18 TO W. INTERFACE	SIDE ELECTRICAL PANEL, LEFT SIDE, REF. PICTURE B. P.11
14	HB1/HC1 INTERFACE	SIDE ELECTRICAL PANEL, MIDDLE, REF. PICTURE B. P.11
15	HB1/HC1 INTERFACE	SIDE ELECTRICAL PANEL, MIDDLE, REF. PICTURE B. P.11
16	KNEELING HARNESS	SIDE ELECTRICAL PANEL, MIDDLE, REF. PICTURE B. P.11
17	HB1 TO HB2 BODY H.	SIDE ELECTRICAL PANEL, MIDDLE, REF. PICTURE B. P.11
18	HB1 TO LUGG. COMP. H	NO CONNECTOR USED, CIRCUIT RUNS TO LUGGAGE COMP.
19	HB2 TO HB3 INTERFAC	BEHIND PARCEL RACK LEFT REAR
20	HB3 TO HC8 INTERFAC	NO CONNECTOR USED, CIRCUIT RUNS TO HC8 HARNESS
21	HB3 TO HC8 INTERFAC	NO CONNECTOR USED, CIRCUIT RUNS TO HC8 HARNESS
22	P7 TO MARKER LIGHTS	AT THE LIGHTS
23	P8 TO MARKER LIGHTS	AT THE LIGHTS
24	P9 TO DRIVING L.	AT THE LIGHTS
25	P10 TO DRIVING L.	AT THE LIGHTS
26	P4 TO REAR ID L.	AT THE LIGHTS
27	P5 TO REAR ID L.	AT THE LIGHTS
28	P6 TO REAR ID L.	AT THE LIGHTS

S21 SOLID-STATE DIMMER, DASH

HEADLIGHT

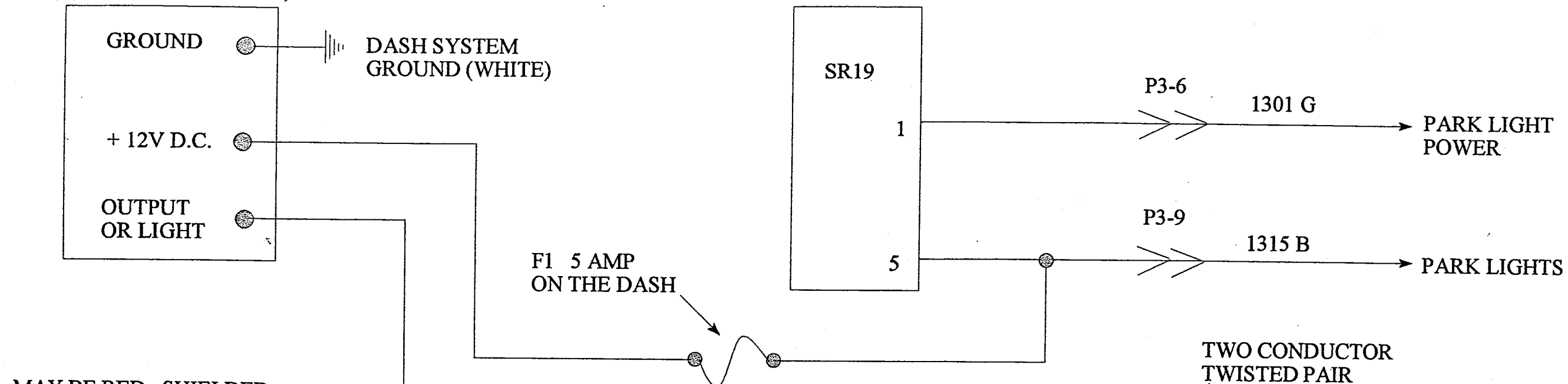

MAY BE RED, SHIELDED, TWISTED PAIR USED FOR MECH. STABILITY

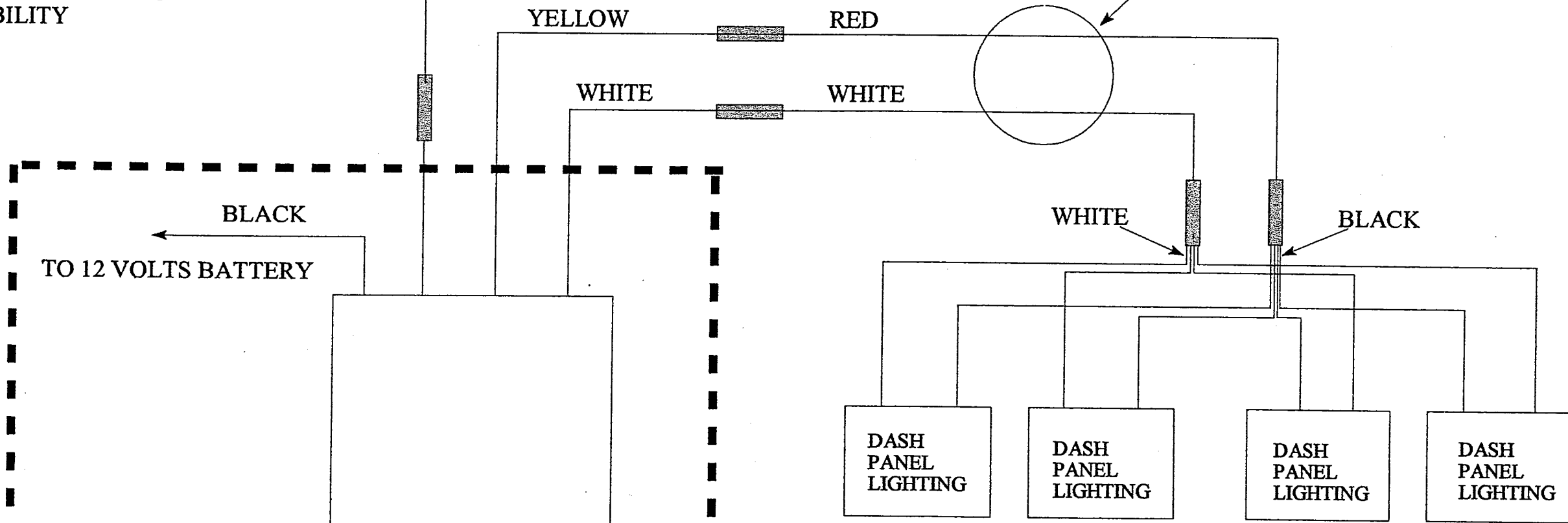

DRIVERS COMPARTMENT (SPARE TIRE ASSESS)

LTC DASH ELECTRO LUMINESCENT LIGHTING