

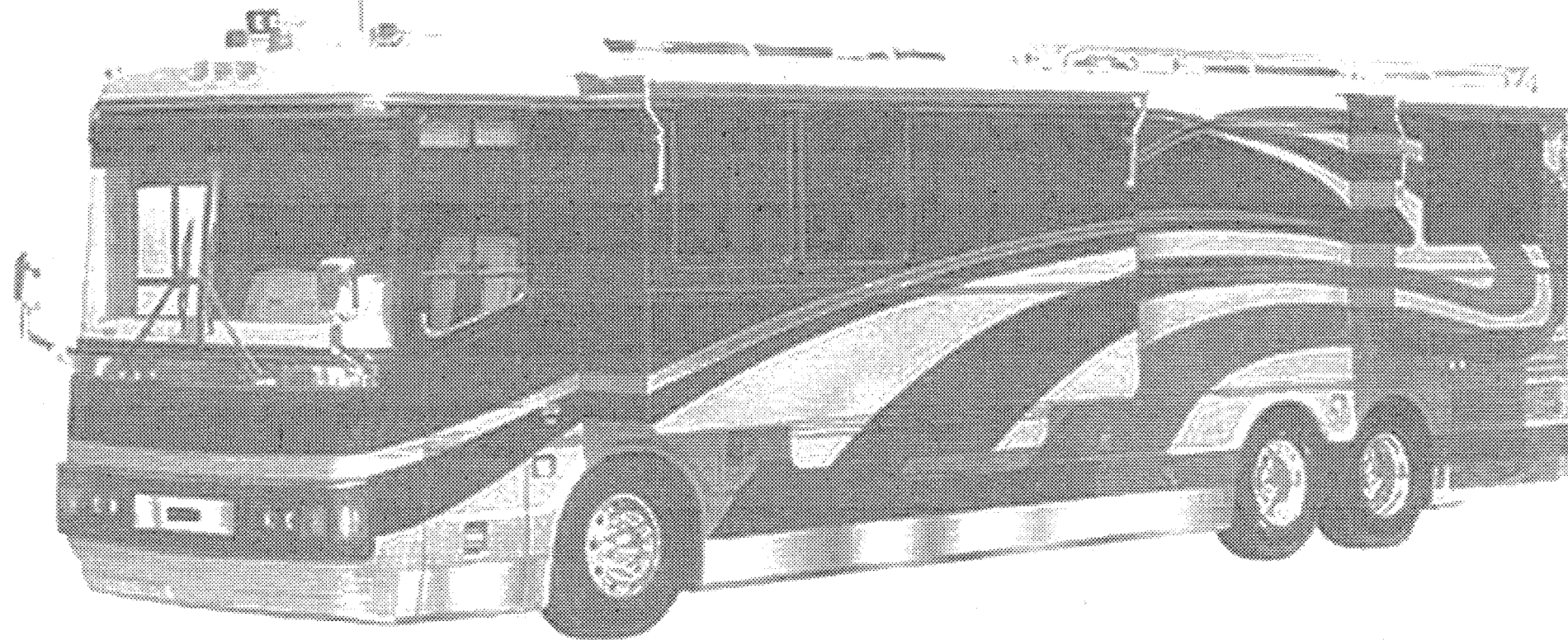

BLUE BIRD

WANDERLODGE



**ELECTRICAL SYSTEM
BOOKLET #2**

25	1971001	D. WRG. ABS LTC-40
26	0015958	D. WRG. KNEELING FEATURE
27	1960053	D. INSTRUCTIONS BODY
28	0000009	D. WRG. DECAL FRONT ELECTRICAL PANEL DDEC
29	0000880	D. WRG. SIDE ELECTRICAL PANEL LAYOUT
30	1990977 #1	D. WRG POWER DISTRIBUTION INPUT
31	1990977 #2	E. WRG. POWER DISTRIBUTION INPUT
32	1996743	E. WRG. POWER DISTRIBUTION FUSED M11
33	1960004	E. WRG. POWER DISTRIBUTION FUSED DDEC
34	1995349 #1	D. WRG. GROUND DIST. M11
35	1995349 #2	D. WRG. GROUND DIST. M11
36	1995349 #3	D. WRG. GROUND DIST. M11
37	1995349 #4	D. WRG. GROUND DIST. M11
38	1995349 #5	D. WRG. GROUND DIST. M11
39	1999838 #1	D. WRG. GROUND DIST. DDEC
40	1999838 #2	D. WRG. GROUND DIST. DDEC
41	1999838 #3	D. WRG. GROUND DIST. DDEC
42	1999838 #4	D. WRG. GROUND DIST. DDEC
43	1999838 #5	D. WRG. GROUND DIST. DDEC
44	0002279	D. WRG. HEAD LIGHT CRICUIT
45	0010389	D. WRG. TAIL LIGHTS

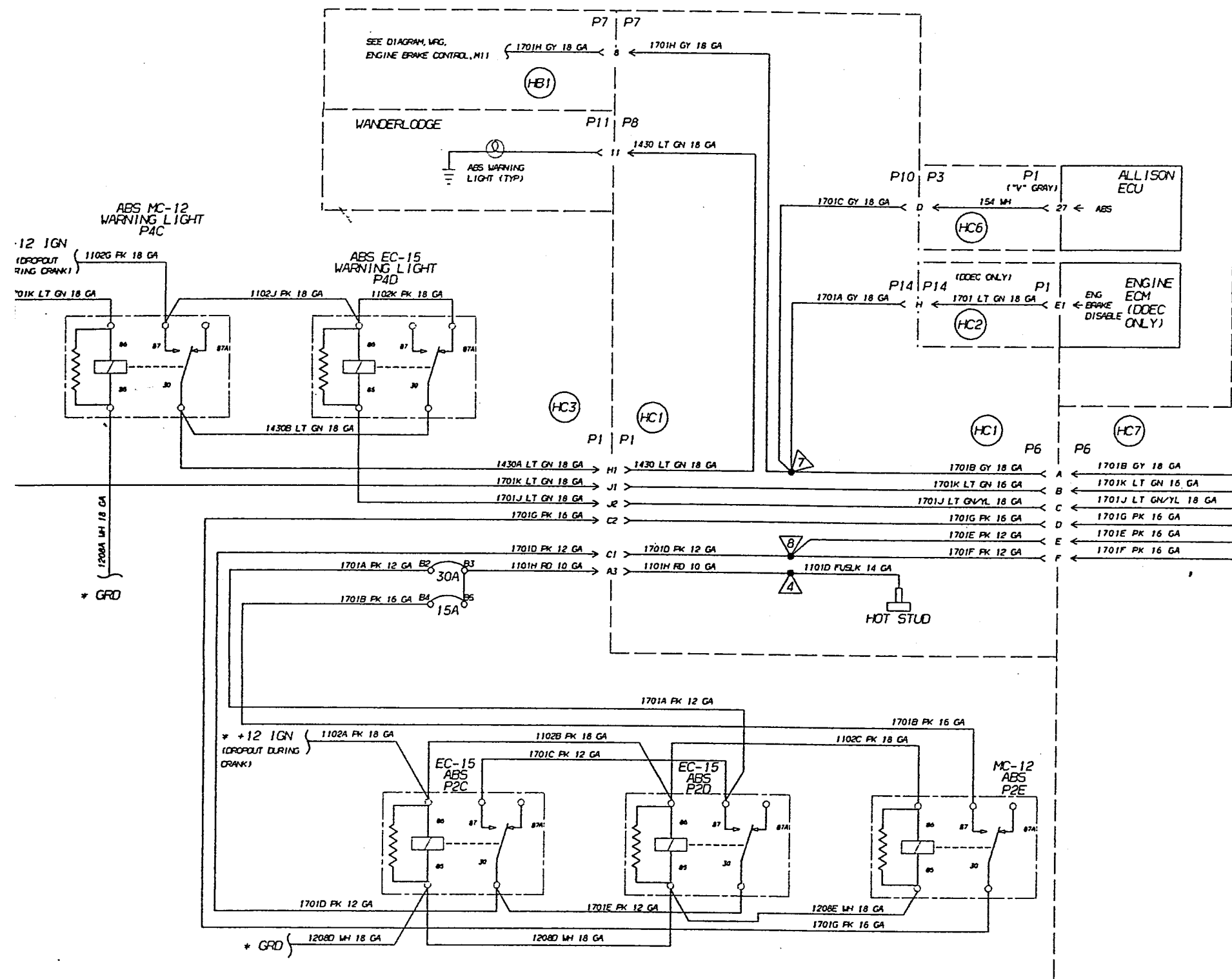

SINGLE CHANNEL ABS COMPUTER

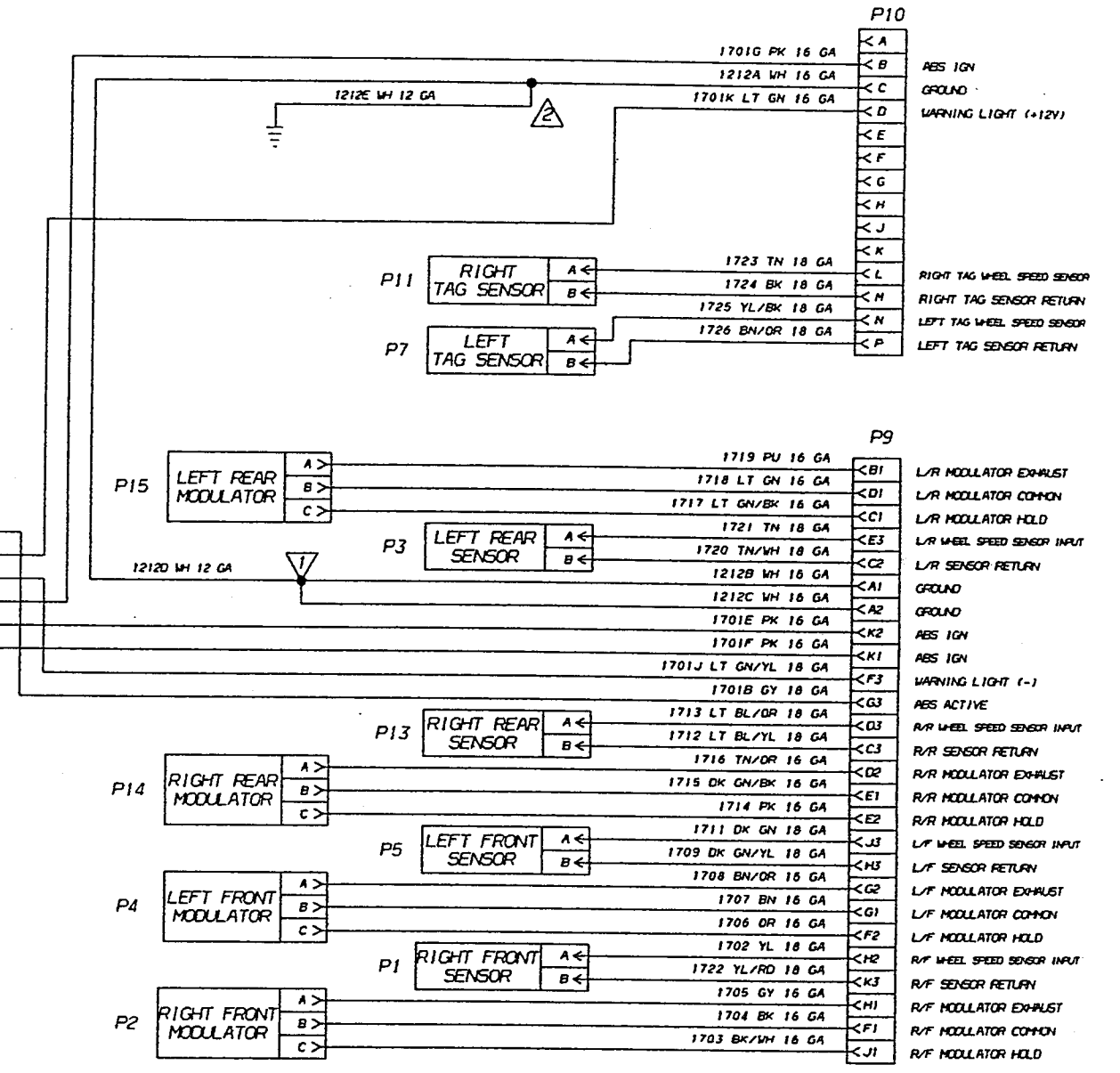

4 CHANNEL ABS COMPUTER

* SEE DIAGRAM, WRG, PANEL, ELECTRICAL, REAR

D. WRG. ABS LTC-40 1971001

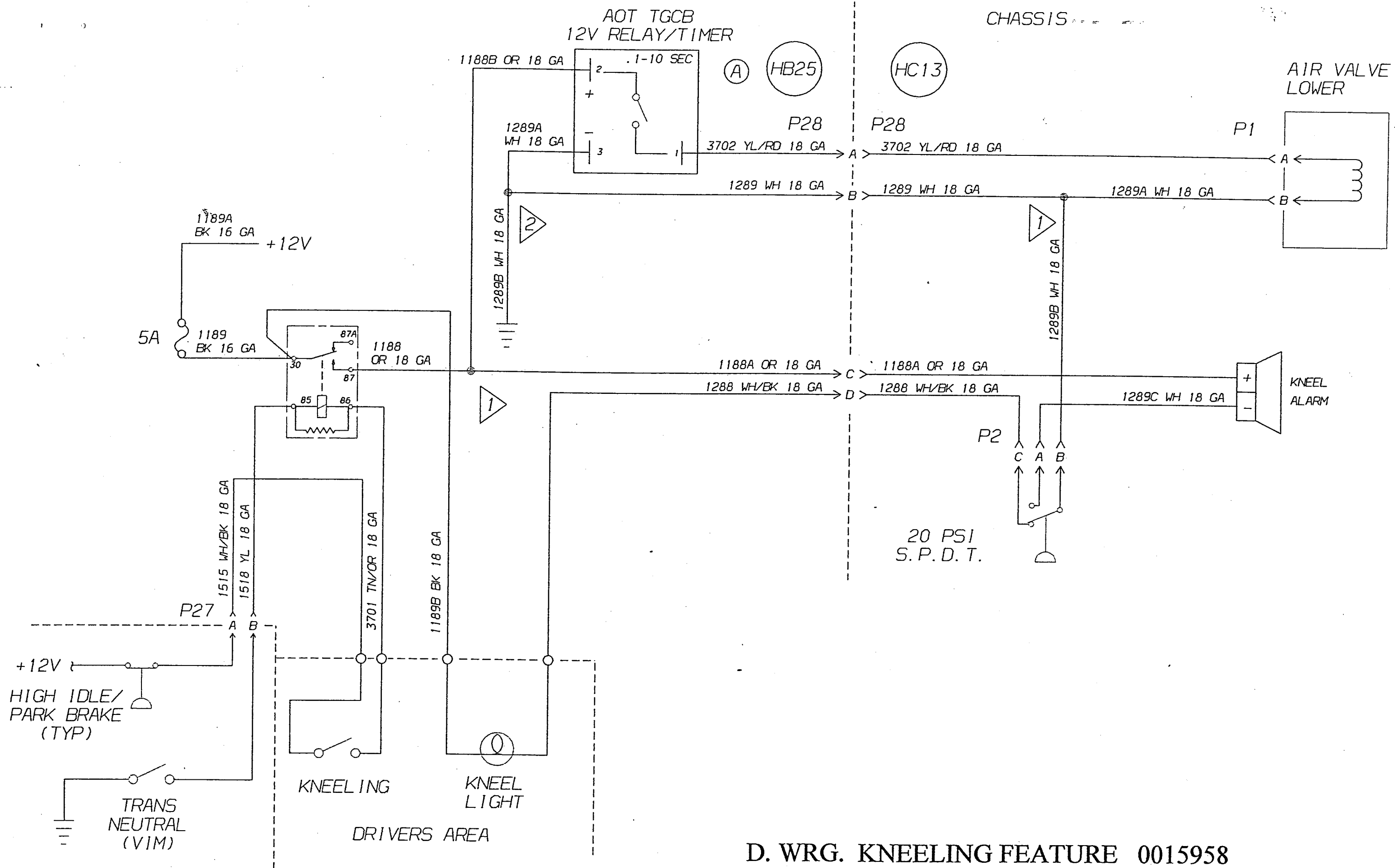

D. WRG. KNEELING FEATURE 0015958

BODY

HARNESS CODE	PART-NO	-----DESCRIPTION-----	
HB1	0012328	HARNESS, WRG, ELEC PANEL, O/S ACS, FRONT W4RE	(B)
HB1	0002287	HARNESS, WRG, ELEC PNL, O/S ACS, FRT, M11 B4/Q4	(B)
HB1	0002295	HARNESS, WRG, ELEC PNL, O/S ACS, FRT, DDEC Q4RE	(B)
HB2	1954148	HARNESS, WRG, BODY, HB2 B4RE/Q4RE/W4RE	(B)
HB3	0005744	HARNESS, WRG, REAR CAP, HB3 Q4RE	(B)
HB3	0010421	HARNESS, WRG, REAR CAP, HB3 B4RE/W4RE	(B)
HB4	0010462	HARNESS, WRG, REAR CAP, LOWER, HB4 W4RE	(B)
HB4	0010413	HARNESS, WRG, REAR CAP, LOWER, HB4 B4RE	(B)
HB5	0010488	HARNESS, WRG, LIGHTS, LH, RR, HB5 B4RE	(B)
HB5	0010504	HARNESS, WRG, LIGHTS, LH RR, HB5 W4RE	(B)
HB6	0010512	HARNESS, WRG, LIGHTS, RH RR, HB6 W4RE	(B)
HB6	0010496	HARNESS, WRG, LIGHTS, RH, RR, HB6 B4RE	(B)
HB7	0002311	HARNESS, WRG, FRONT CAP, HB7 B4RE/Q4RE	(B)
HB7	1997998	HARNESS, WRG, FRONT CAP, HB7 W4RE	(B)
HB8	1958297	WIRE ASSY, SI DIR, LT FRT B4/Q4/W4	(B)
HB9	1958305	WIRE ASSY, SI DIR, LT RR B4/Q4/W4	(B)
HB10	1958313	WIRE ASSY, SI DIR, RT FRT B4/Q4/W4	(B)
HB11	1958321	WIRE ASSY, SI DIR, RT RR B4/Q4/W4	(B)
HB12	1958255	WIRE ASSY, LANDING, LGTS, LT FRT B4/W4	(B)
HB13	1958263	WIRE ASSY, LANDING, LGTS, LT RR B4/W4	(B)
HB14	1958271	WIRE ASSY, LANDING, LGTS, RT FRT B4/W4	(B)
HB15	1958289	WIRE ASSY, LANDING, LGTS RT RR B4/W4	(B)
HB17	1985167	HARNESS, WRG, STEERING COLUMN, HB17 W4RE	(B)
HB18	1446525	HARNESS, WRG, ENGINE CMPT, LGT & HEAT SEN WLWB	(B)
HB19	1996735	HARNESS, WRG, LOCKS & LIGHTS, L/CMPT W4RE	(B)
HB20	1969955	HARNESS, WRG, LIGHTS, L/CMPT B4/Q4	(A)
HB21	0015933	HARNESS, WRG, LGTS, L/CMPT, E/PNL, HB21 B4/Q4	(B)
HB22	0016063	HARNESS, WRG, ELEC SERVICE DOOR, E/PNL, HB22 Q4	(B)
HB23	0016071	HARNESS, WRG, ELEC SERVICE DR, FRT CAP, HB23 Q4	(B)
HB24	0000216	HARNESS, WRG, KEYED SW, ELEC SVC DR, HB24 Q4	(B)
HB25	0015982	HARNESS, WRG, KNEELING, CONTROL, HB25 Q4RE	(D)

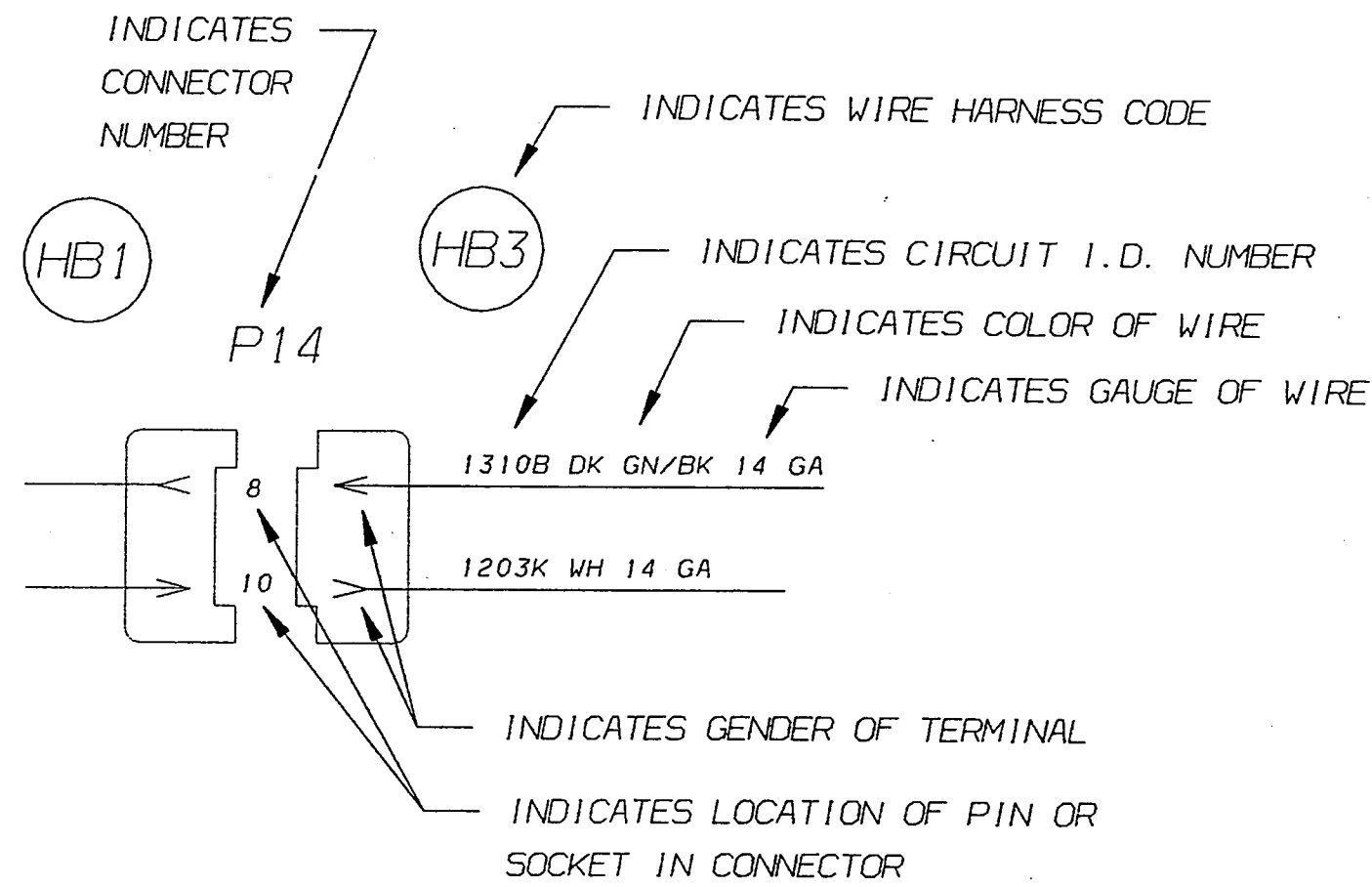
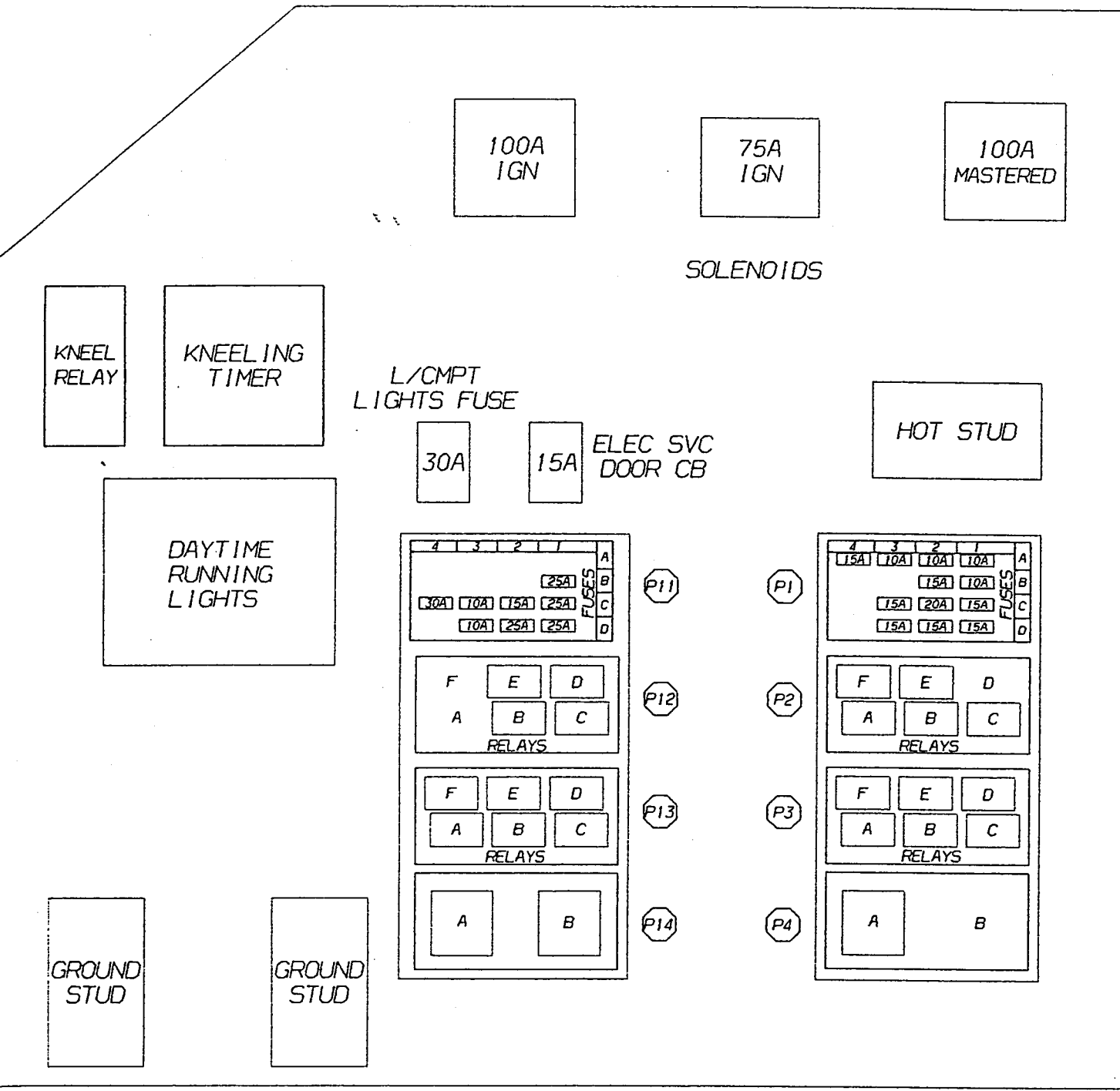

DIAGRAM INSTRUCTIONS BODY

1960053#1



FUSE CHART P11

LOCATION	AMP	DESCRIPTION
P11A1	--	NOT USED
P11A2	--	NOT USED
P11A3	--	NOT USED
P11A4	--	NOT USED
P11B1	25	MASTERED ACCESSORY
P11B2	--	SPARE
P11B3	--	SPARE
P11B4	--	SPARE
P11C1	25	IGNITION
P11C2	15	DRL CTRL
P11C3	10	FUEL SENSOR
P11C4	30	HVAC
P11D1	25	DIR FLASHER
P11D2	25	+12 ACCESSORY
P11D3	10	ENGINE COMPARTMENT
P11D4	--	SPARE

FUSE CHART P1

LOCATION	AMP	DESCRIPTION
P1A1	10	SUSP PRESS PWR/THERMO-KING A/C CTRL
P1A2	10	AIR DRYER
P1A3	10	VIM IGN
P1A4	15	WIPER POWER
P1B1	10	PARK BRAKE
P1B2	15	BACKUP POWER
P1B3	--	SPARE
P1B4	--	ENGINE BRAKE NEUTRAL INTERRUPT (NOT USED)
P1C1	15	HEADLIGHT CONTROL
P1C2	20	HEADLIGHT PWR
P1C3	15	DRL PWR
P1C4	--	SPARE
P1D1	15	HORN
P1D2	15	STOP LIGHT
P1D3	15	CLEARANCE LIGHTS
P1D4	--	VIM (NOT USED)

RELAY CHART P12

LOCATION	DESCRIPTION
P12A	--
P12B	MIRROR SWITCH ILLUMINATION
P12C	HEADLIGHT WARNING
P12D	COOLANT FAN
P12E	CLEARANCE LIGHTS/SALUTE
P12F	--

RELAY CHART P2

LOCATION	DESCRIPTION
P2A	LH WIPER LOW/PARK
P2B	LH WIPER HIGH
P2C	DRL PARK BRAKE CTRL
P2D	--
P2E	RH WIPER HIGH
P2F	RH WIPER LOW/PARK

RELAY CHART P13

LOCATION	DESCRIPTION
P13A	STOP LIGHT
P13B	ENGINE BRAKE CNTRL
P13C	LH DIRECTIONAL
P13D	RH DIRECTIONAL
P13E	ENGINE BRAKE LO/MED
P13F	ENGINE BRAKE HI

RELAY CHART P3

LOCATION	DESCRIPTION
P3A	HEADLIGHT LO BEAM
P3B	PARK BRAKE INTERLOCK
P3C	NEUTRAL START
P3D	CRUISE OVERRIDE
P3E	CLEARANCE LIGHTS
P3F	HORN

COMPONENT CHART P14

LOCATION	DESCRIPTION
P14A	DRIVING LIGHTS
P14B	DIRECTIONAL FLASHER

COMPONENT CHART P4

LOCATION	DESCRIPTION
P4A	HEADLIGHT HI BEAM
P4B	

D. W. DECAL FRONT ELECTRICAL PANEL DDEC 000009

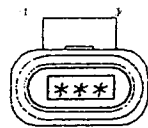

LUGGAGE
COMPARTMENT
LIGHTS FUSE
Q4 PANEL ASSY
#0003709 USE 30A

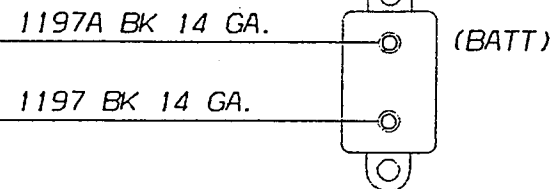

ELEC SVC DOOR
** CIRCUIT BREAKER

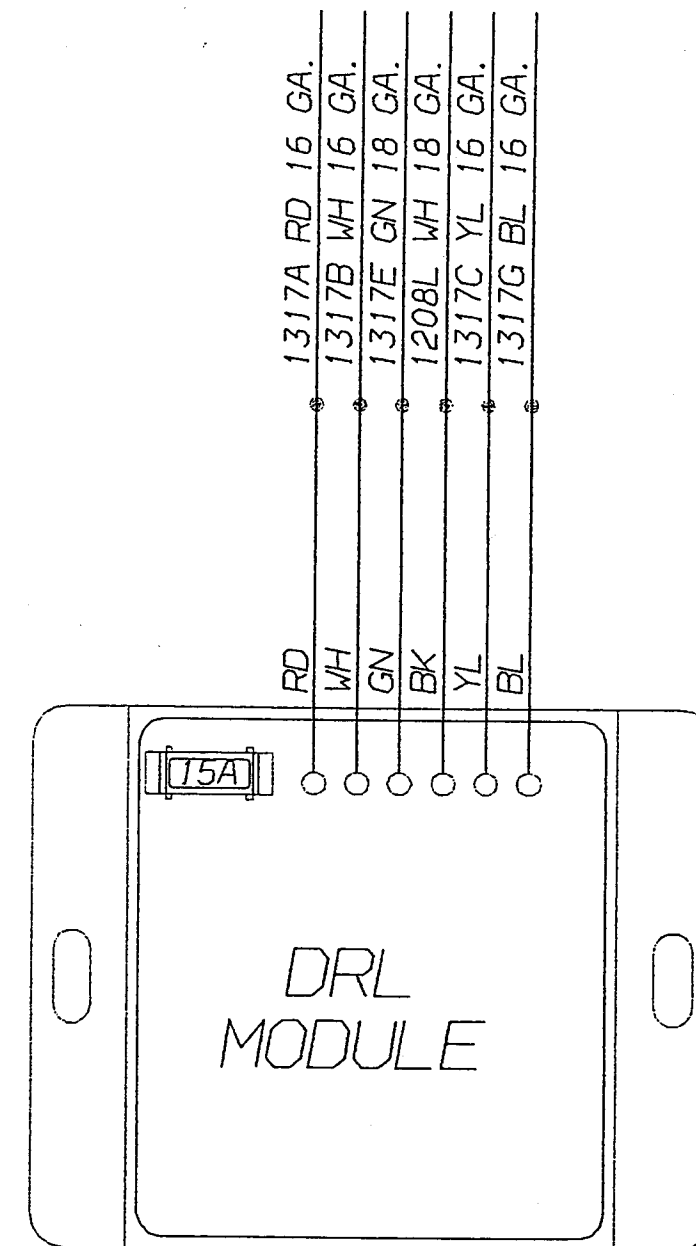
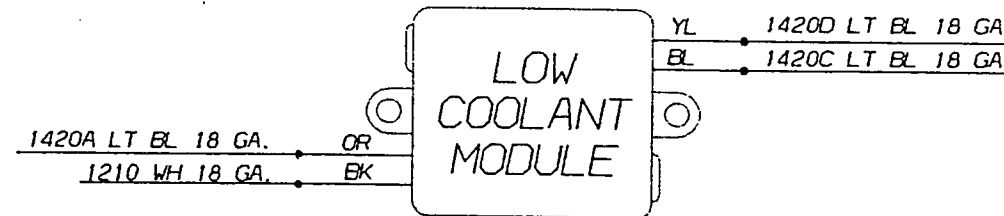
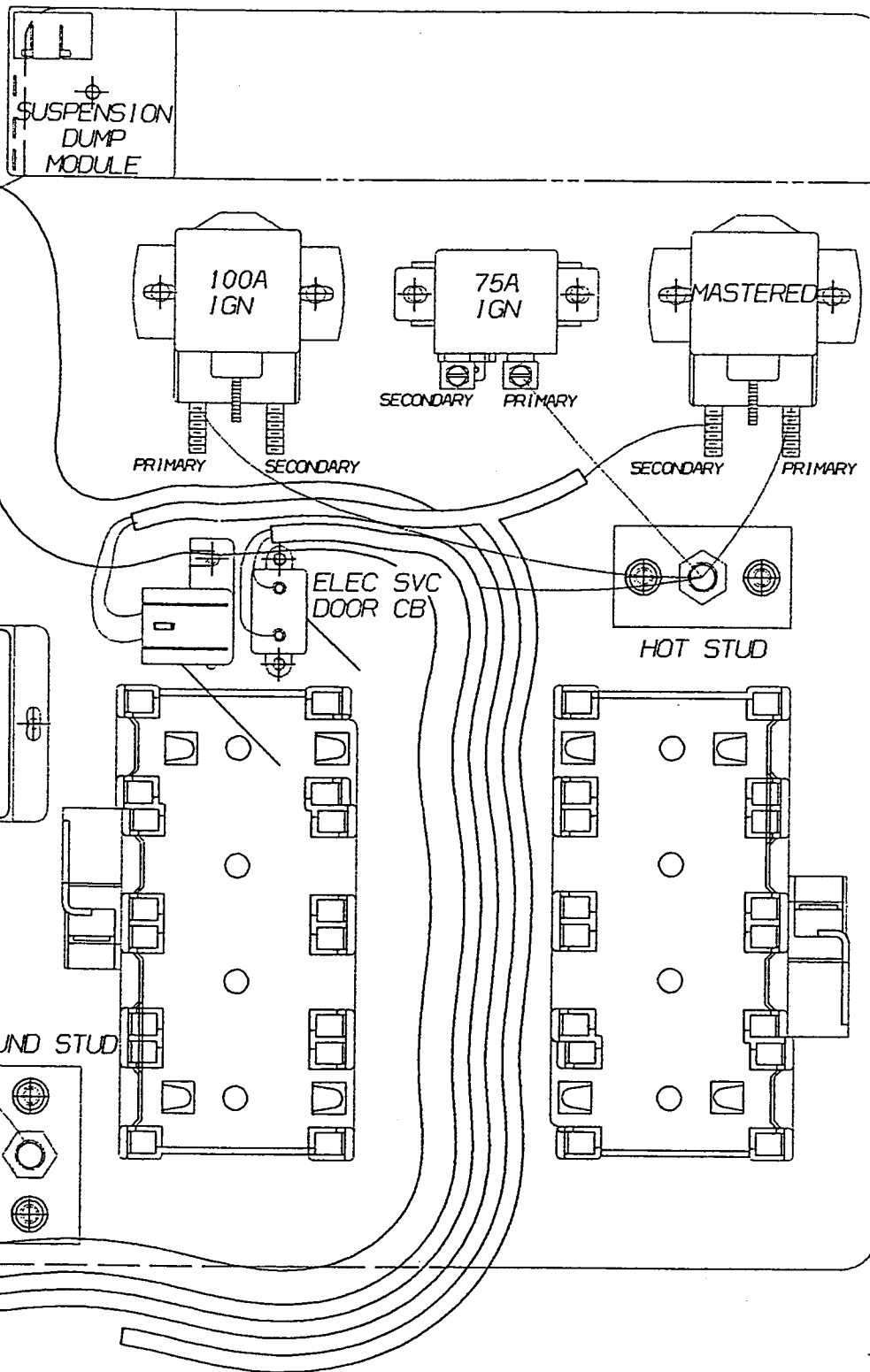

D. W. SIDE ELECTRICAL PANEL 0000880M #1

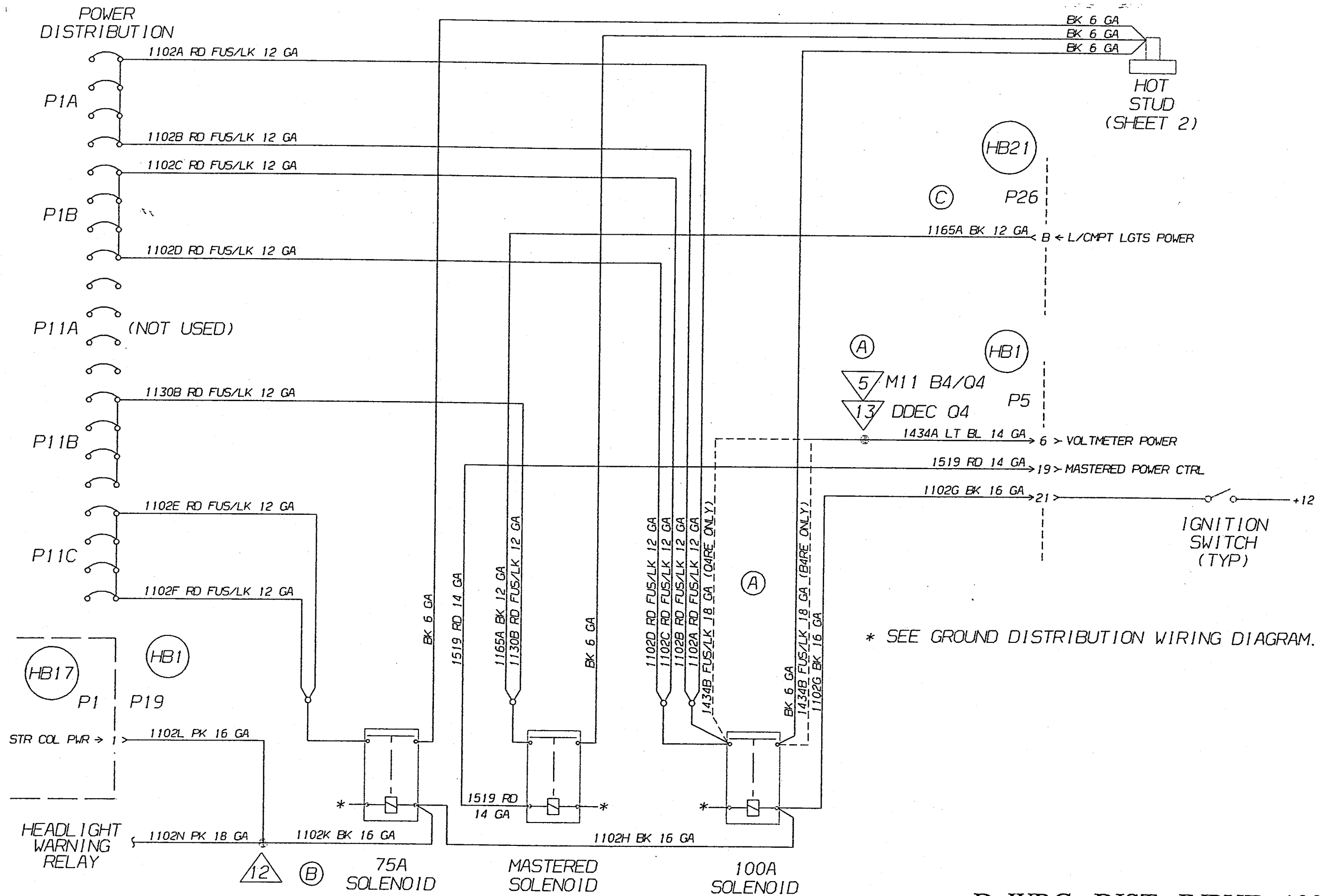

D. WRG. DIST. INPUT 1990977 # 1

POWER DISTRIBUTION

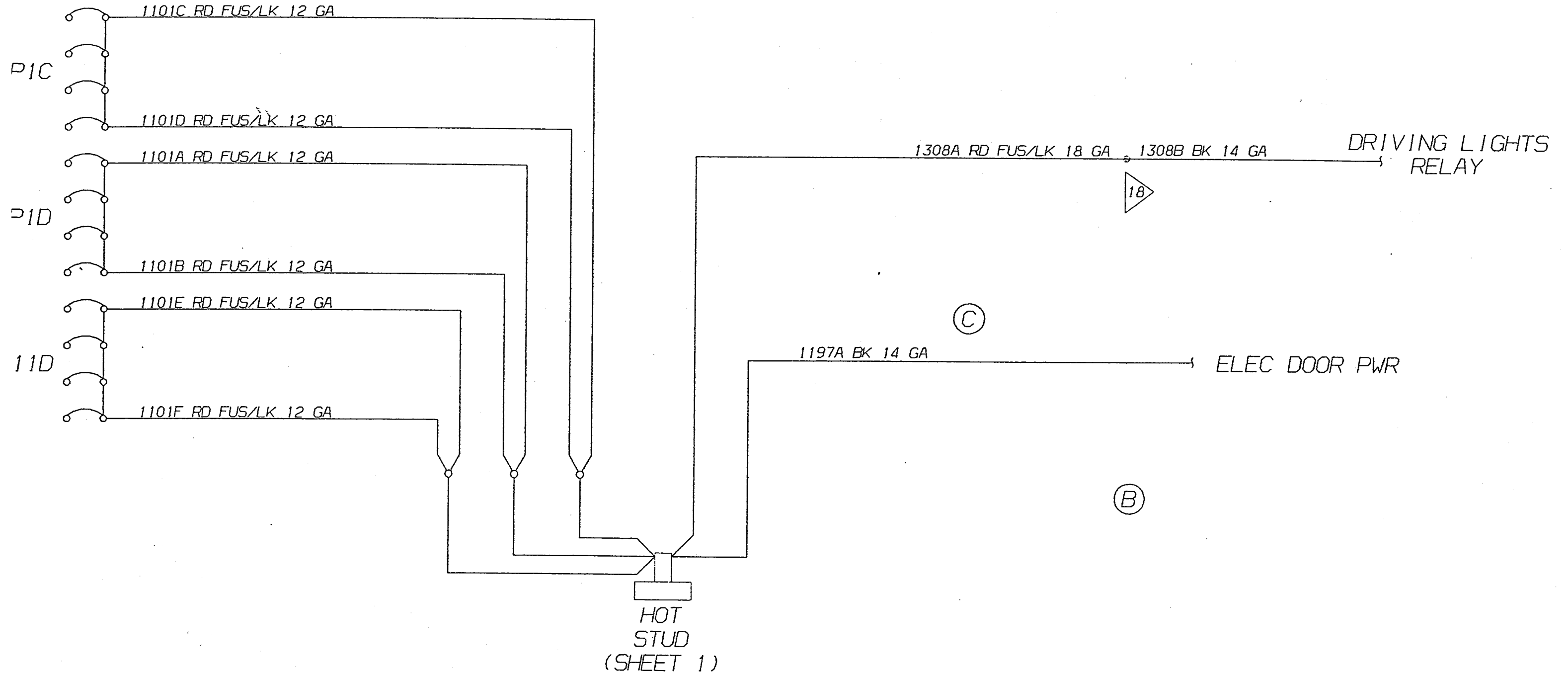

D. WRG. POWER DIST. INPUT 1990977 #2

P11

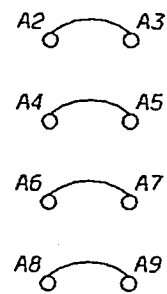

NOT USED

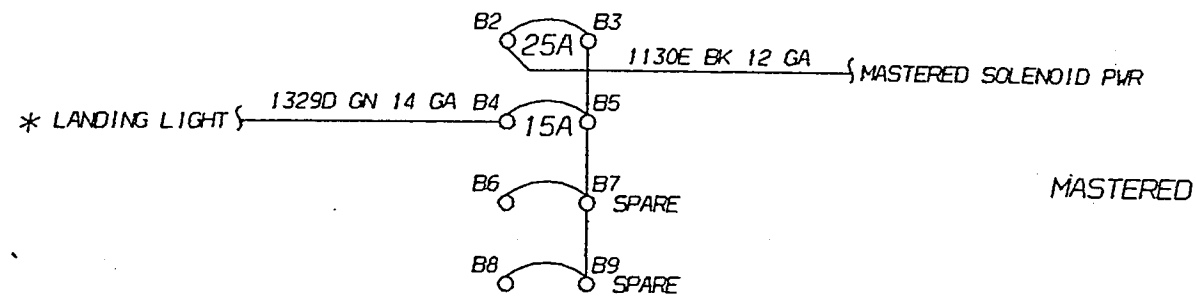

MASTERED

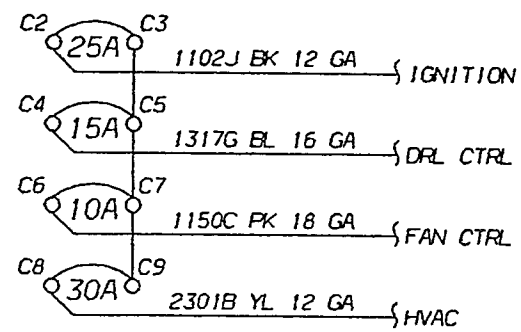

75A

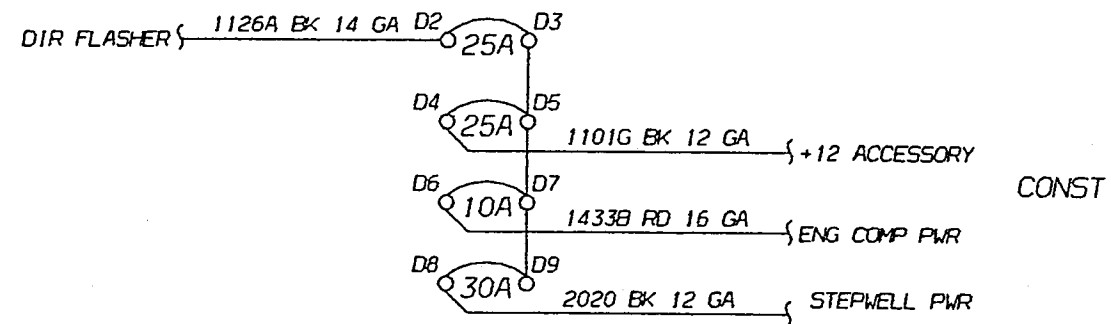

CONST

* B4 ONLY
 ** Q4 ONLY

P1

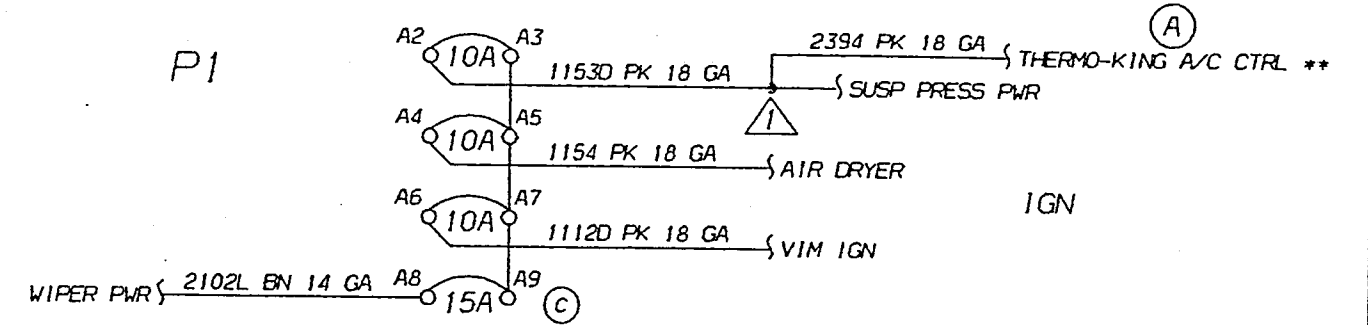

IGN

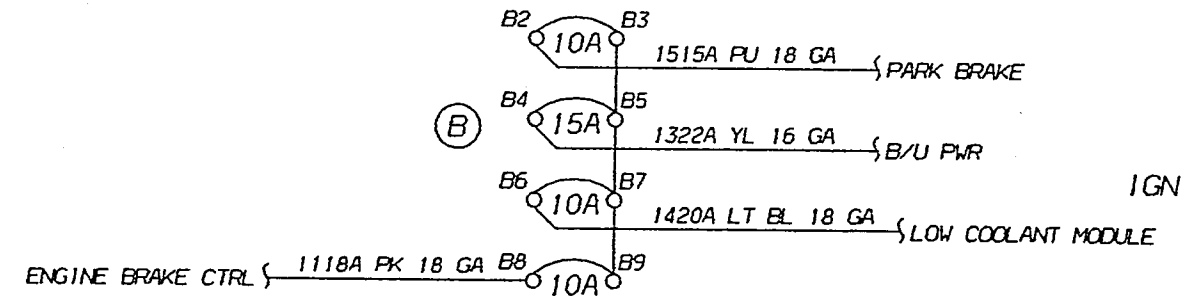

IGN

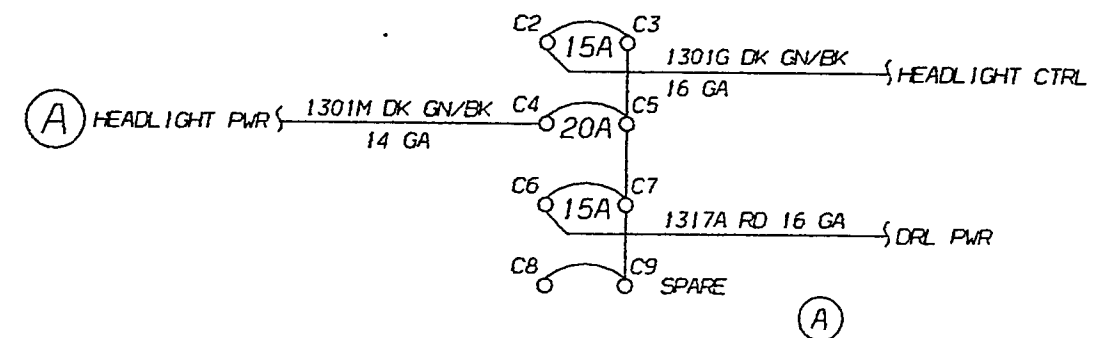

CONST

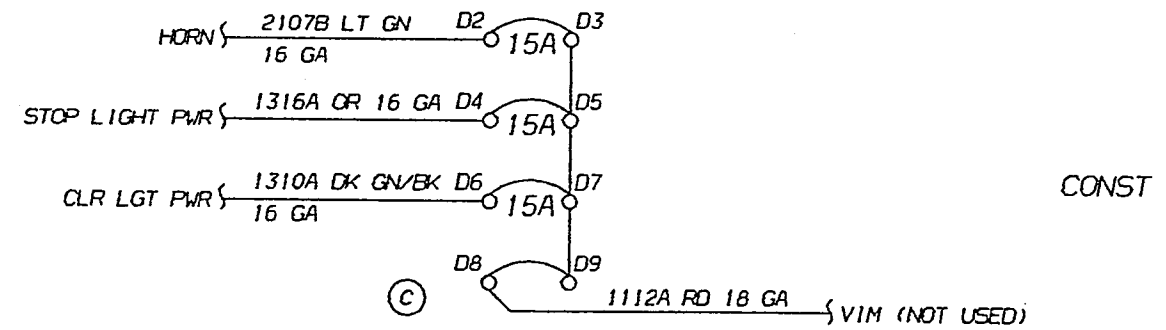

CONST

D. W. POWER DIST. FUSED M11 1996743 REV. C

P11

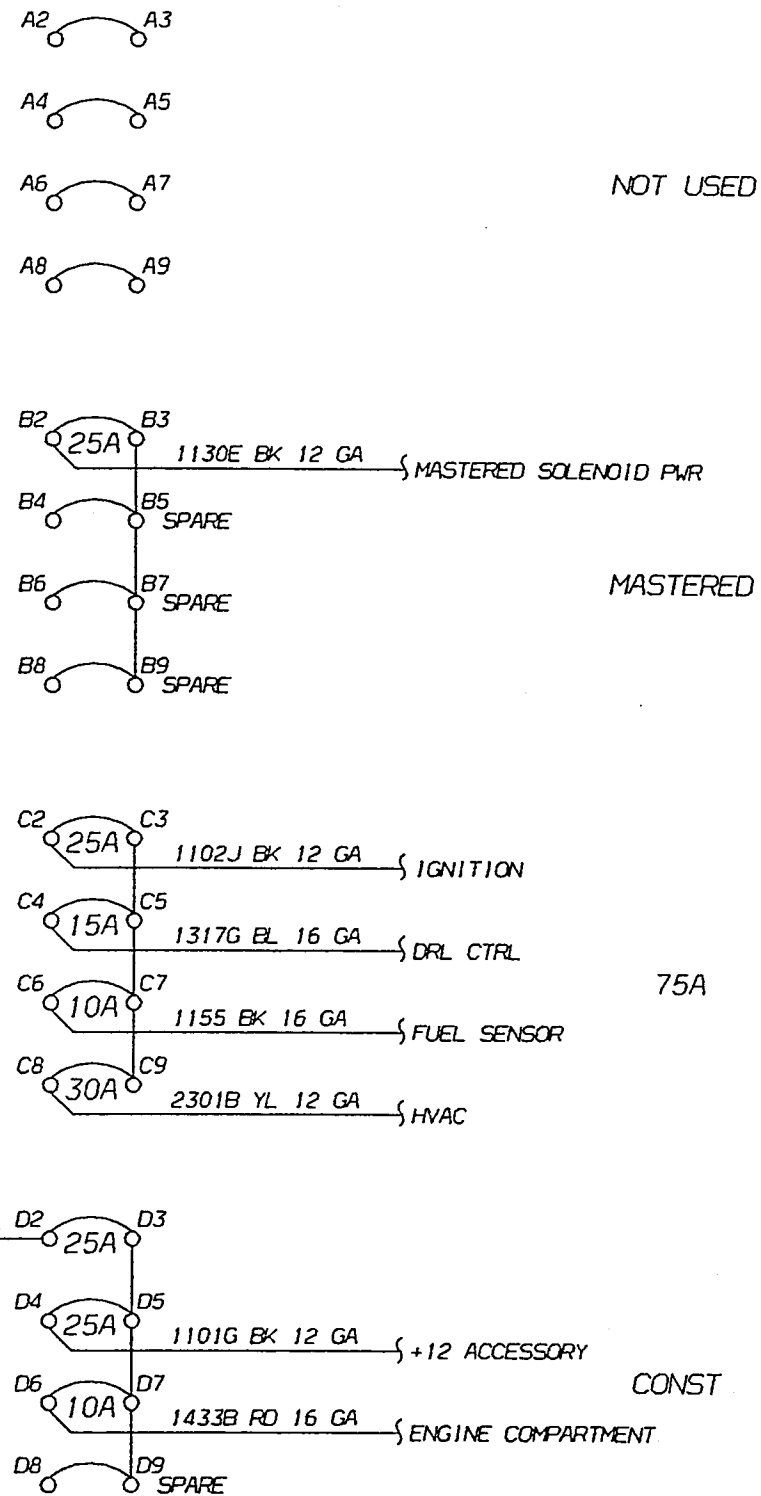

P1

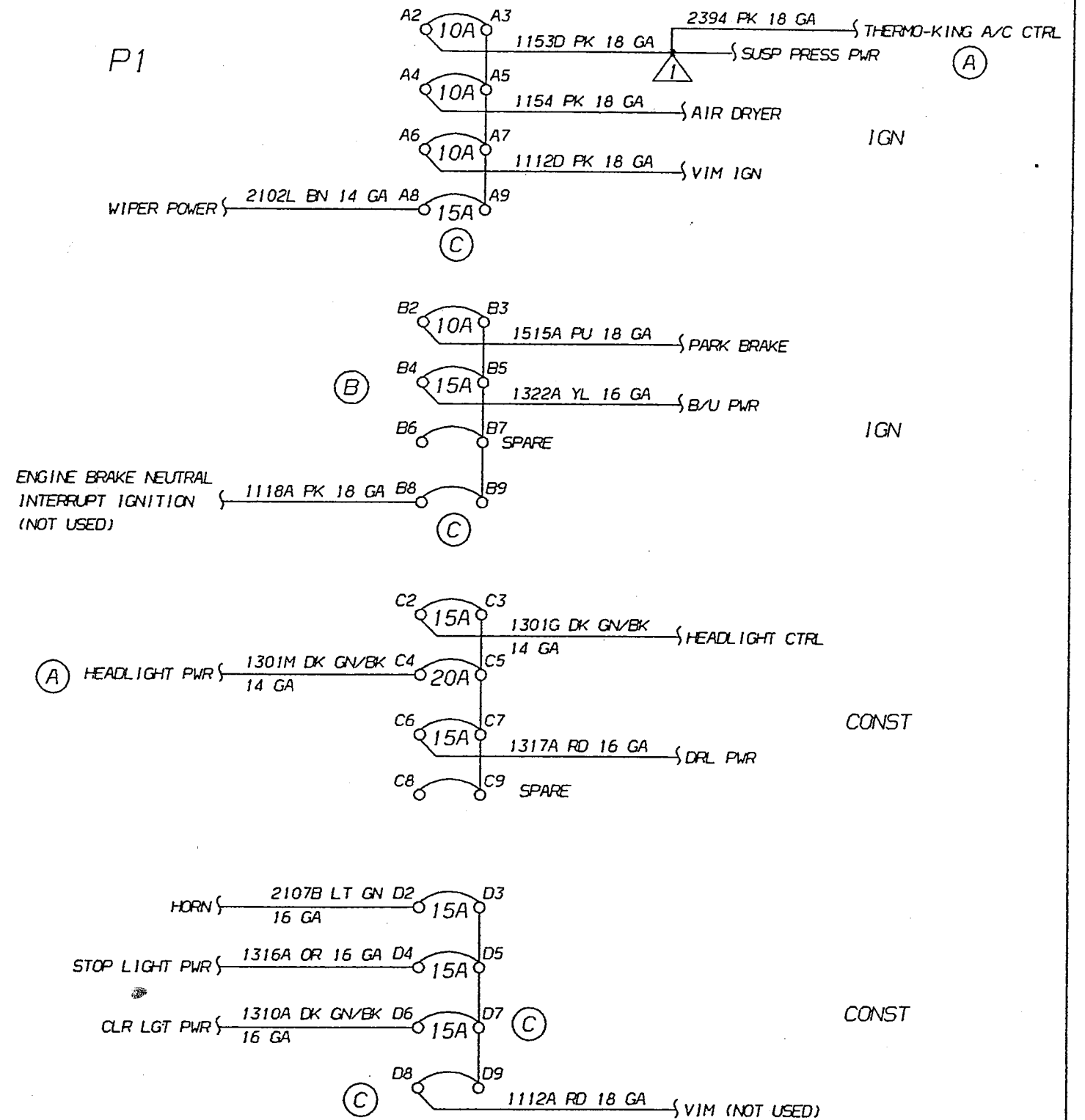

D. WRG. POWER DISTRIBUTION FUSED DDEC 1960004M REV.C

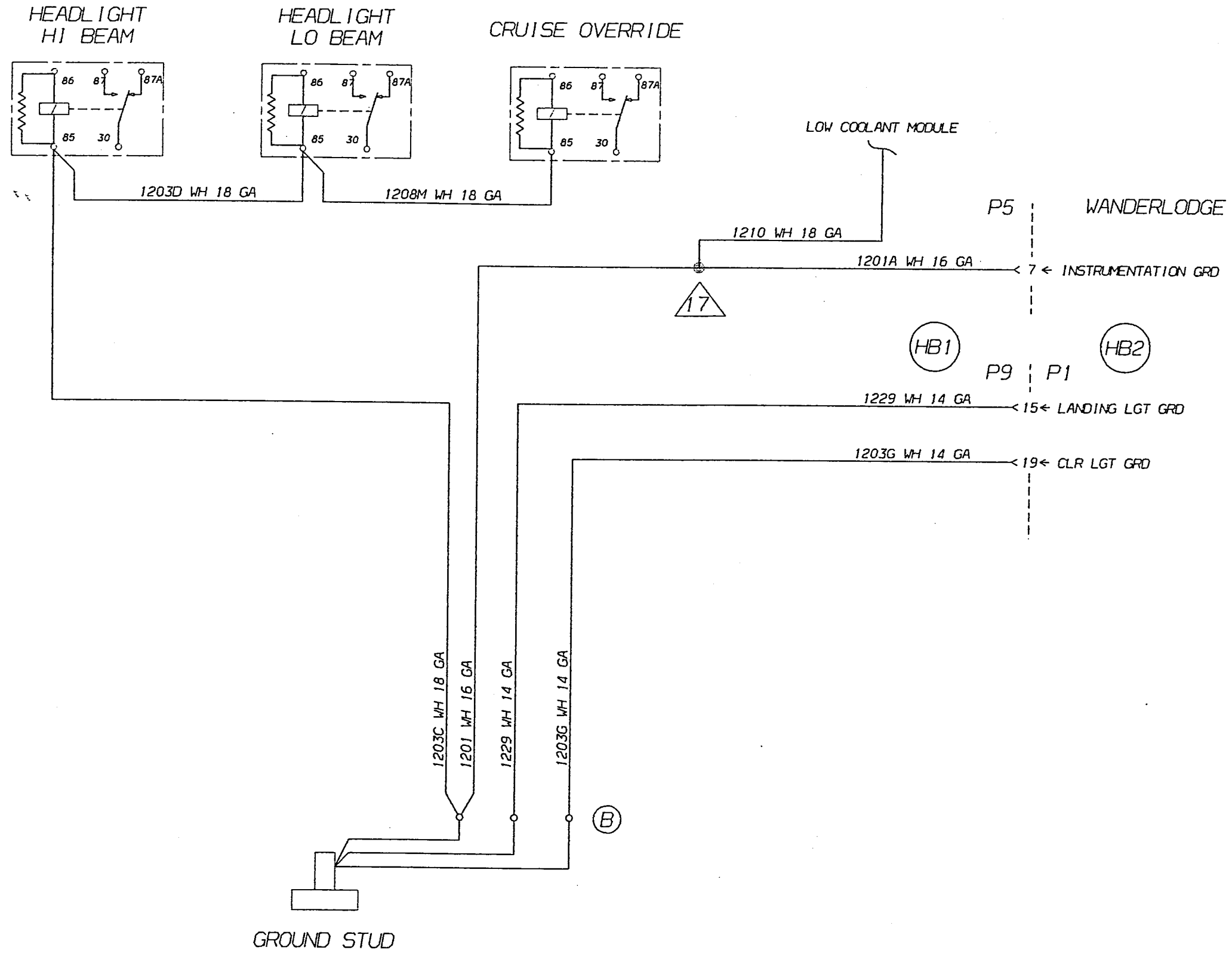

D. W. GROUND DIST. M11 1995349 #1

CLEARANCE LIGHT

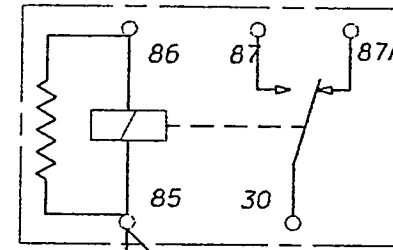

1203H WH 18 GA
1203A WH 18 GA

TO DIR FLASHER

1207 WH 14 GA

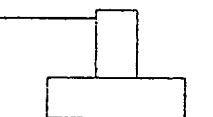

GROUND STUD

CLEARANCE LIGHT SALUTE

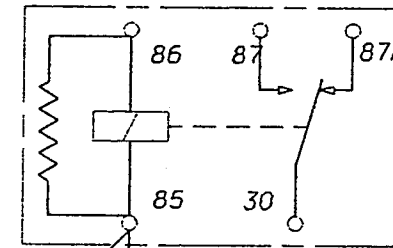

1208P WH 18 GA

COOLANT FAN

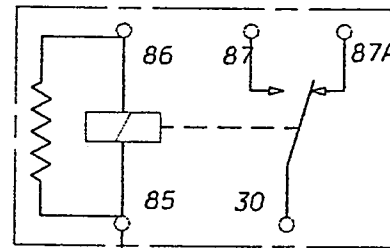

HEADLIGHT WARNING

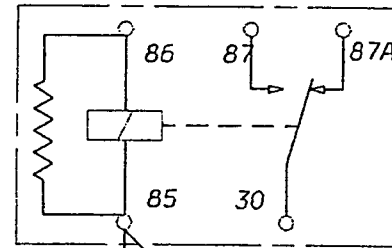

MIRROR SW ILLUMINATION

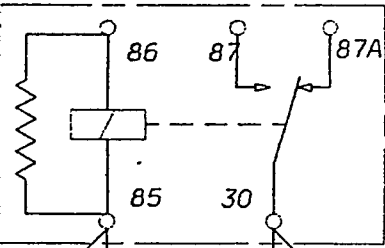

1208R WH 18 GA
1208W WH 18 GA
1208H WH 18 GA

D. W. GROUND DIST. M11 1995349 #2

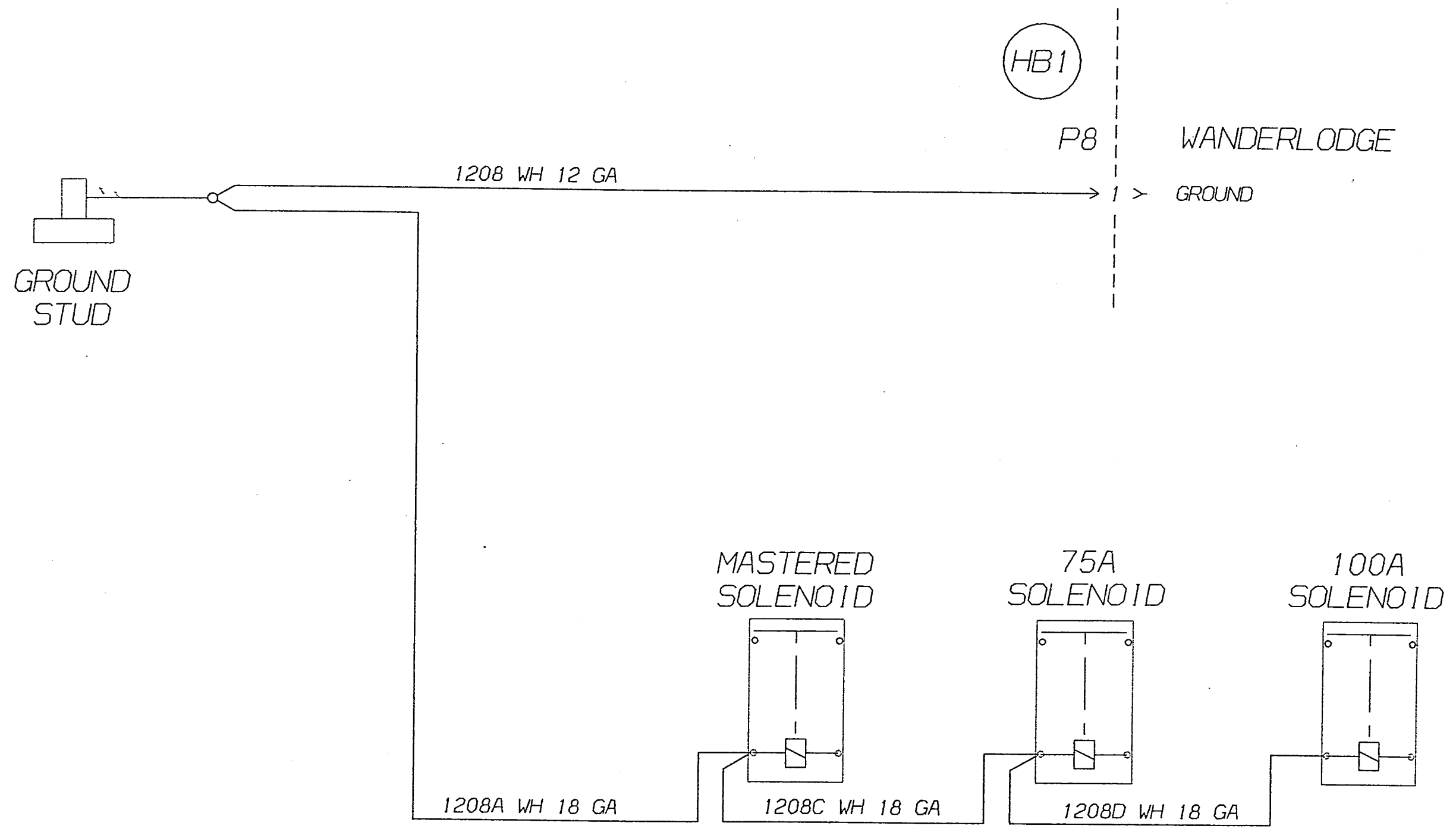

D. W. GROUND DIS. M11 1995349 #3

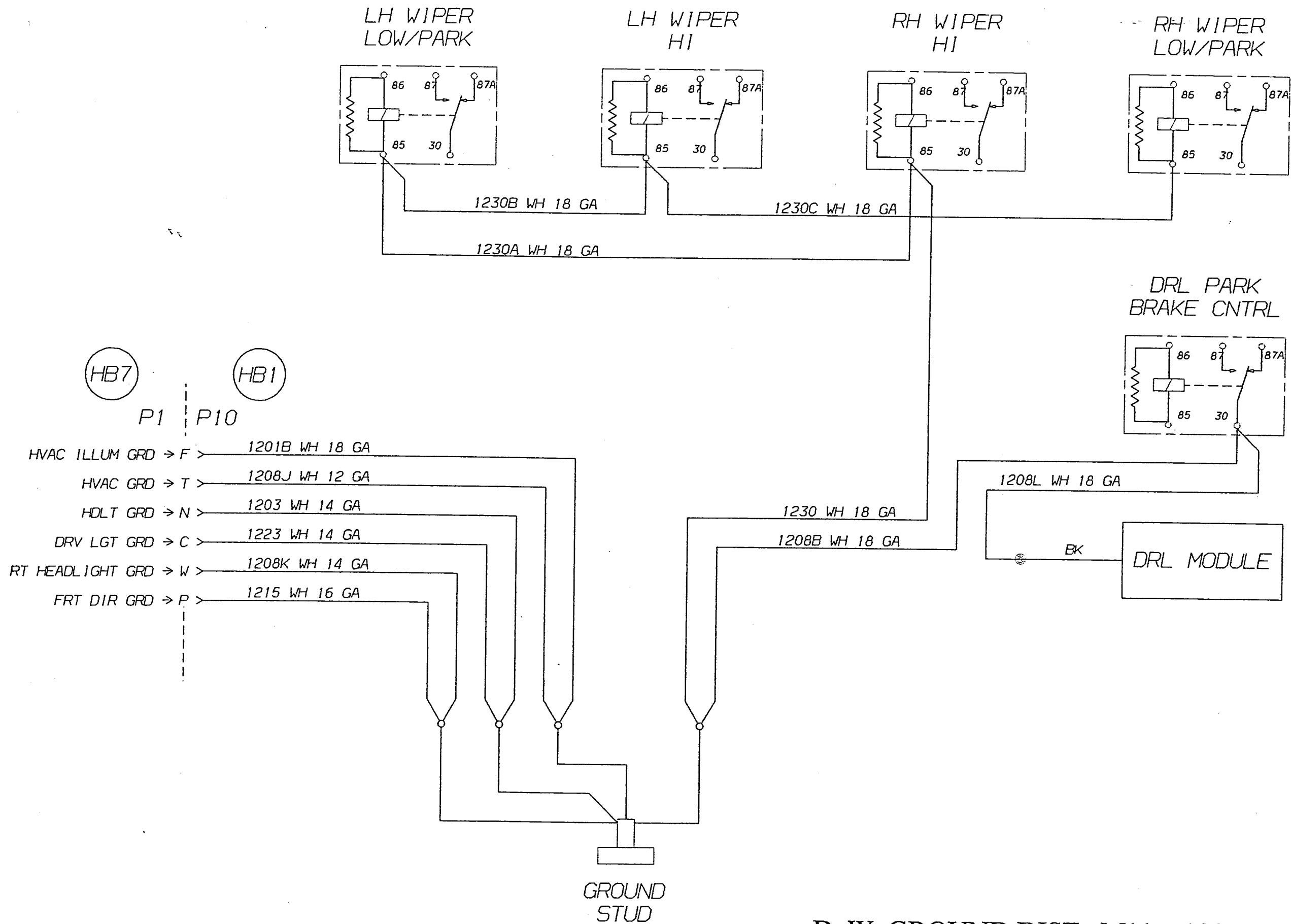

D. W. GROUND DIST. M11 1995349 #4

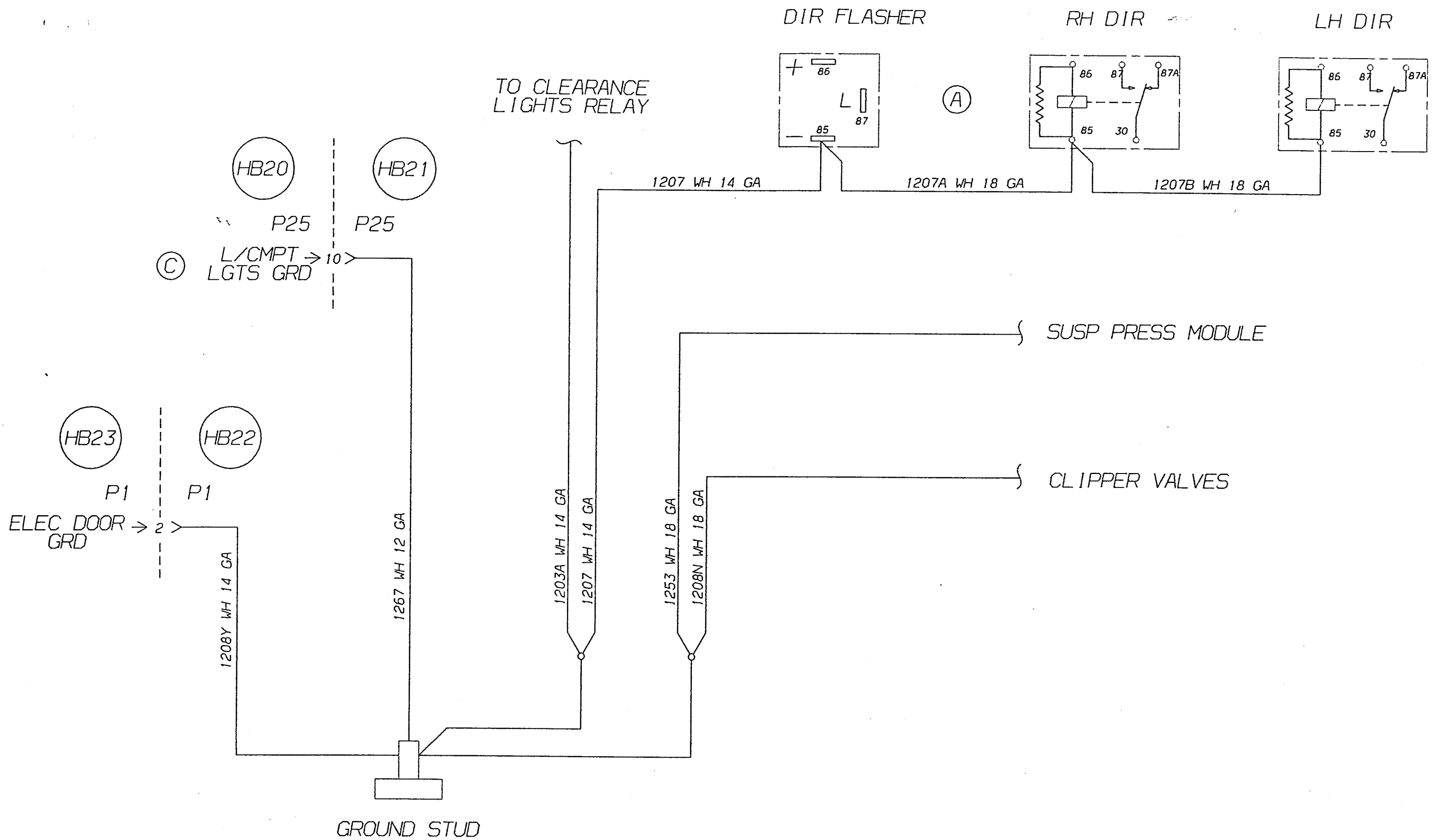

D. W. GROUND DIST. M11 1995349 #5

HEADLIGHT
HI BEAM

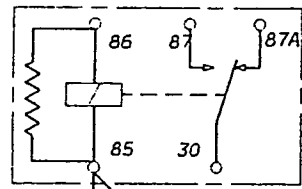

1203D WH 18 GA

HEADLIGHT
LO BEAM

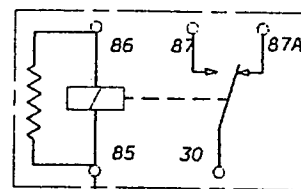

ENG BRAKE
LO/MED

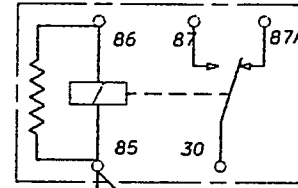

1208E WH 18 GA

ENG BRAKE
HI

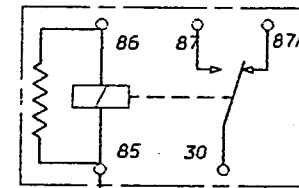

1208G WH 18 GA

WANDERLODGE

HB1

P5

1201A WH 16 GA

7 > INSTRUMENT GRD



1216 WH 18 GA

P6

P9

HC1

23 < BRAKE SW GRD

P9

P1

HB2

1203G WH 14 GA

19 > CLR LGT GRD

1229 WH 14 GA

15 > LANDING LGT GRD

P7

P7

HC1

1255 WH 16 GA

12 > FUEL SENSOR GRD

1203C WH 18 GA

1201 WH 16 GA

1208E WH 18 GA

1203G WH 14 GA

1229 WH 14 GA

1255 WH 16 GA

(B)

GROUND STUD

D. W. GROUND DIST. DDEC 1999838 #1 REV. A

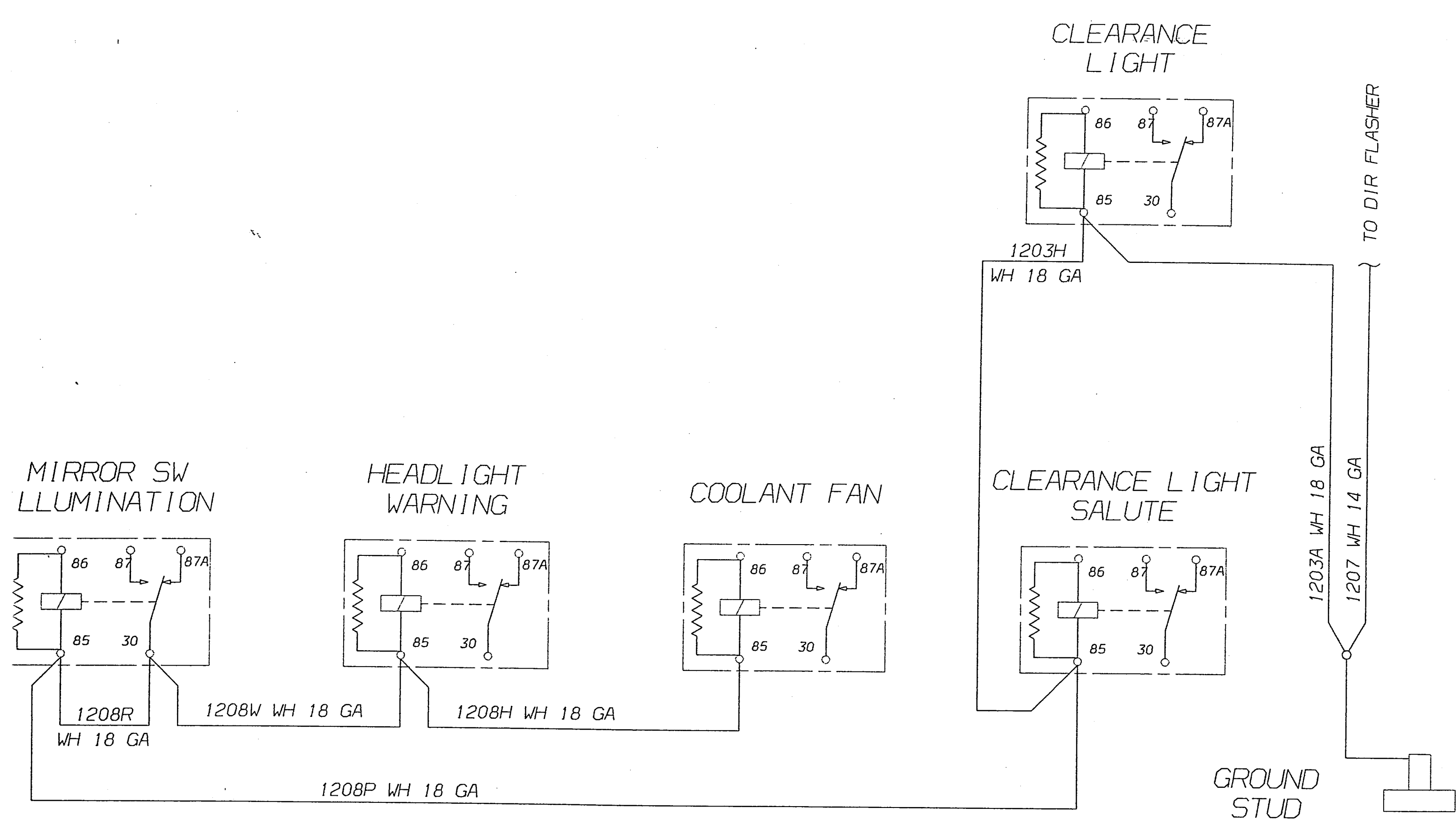

D. W. GROUND DIST. DDEC 1999838 #2 REV. A

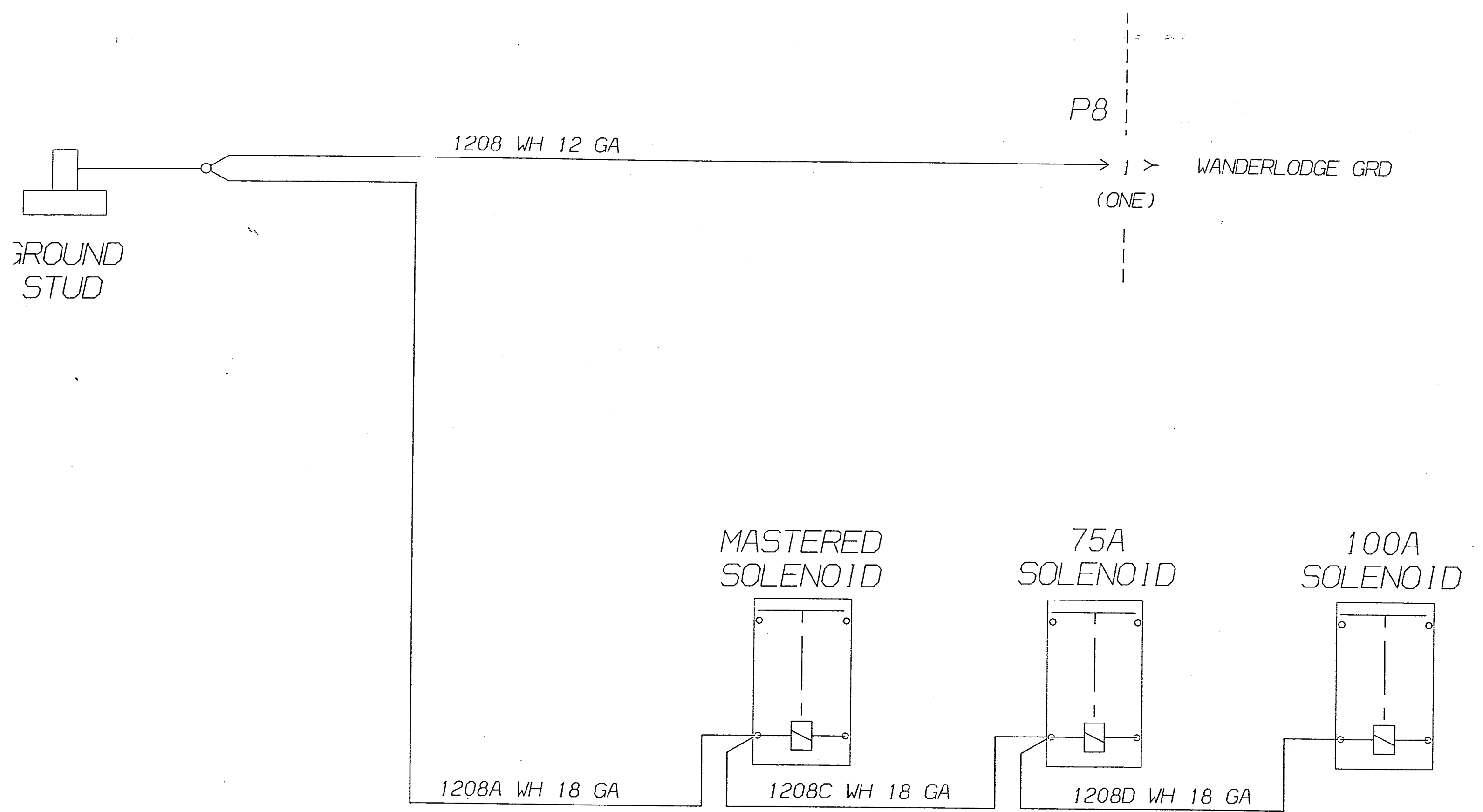

D. W. GROUND DIST. DDEC 1999838 #3 REV. C

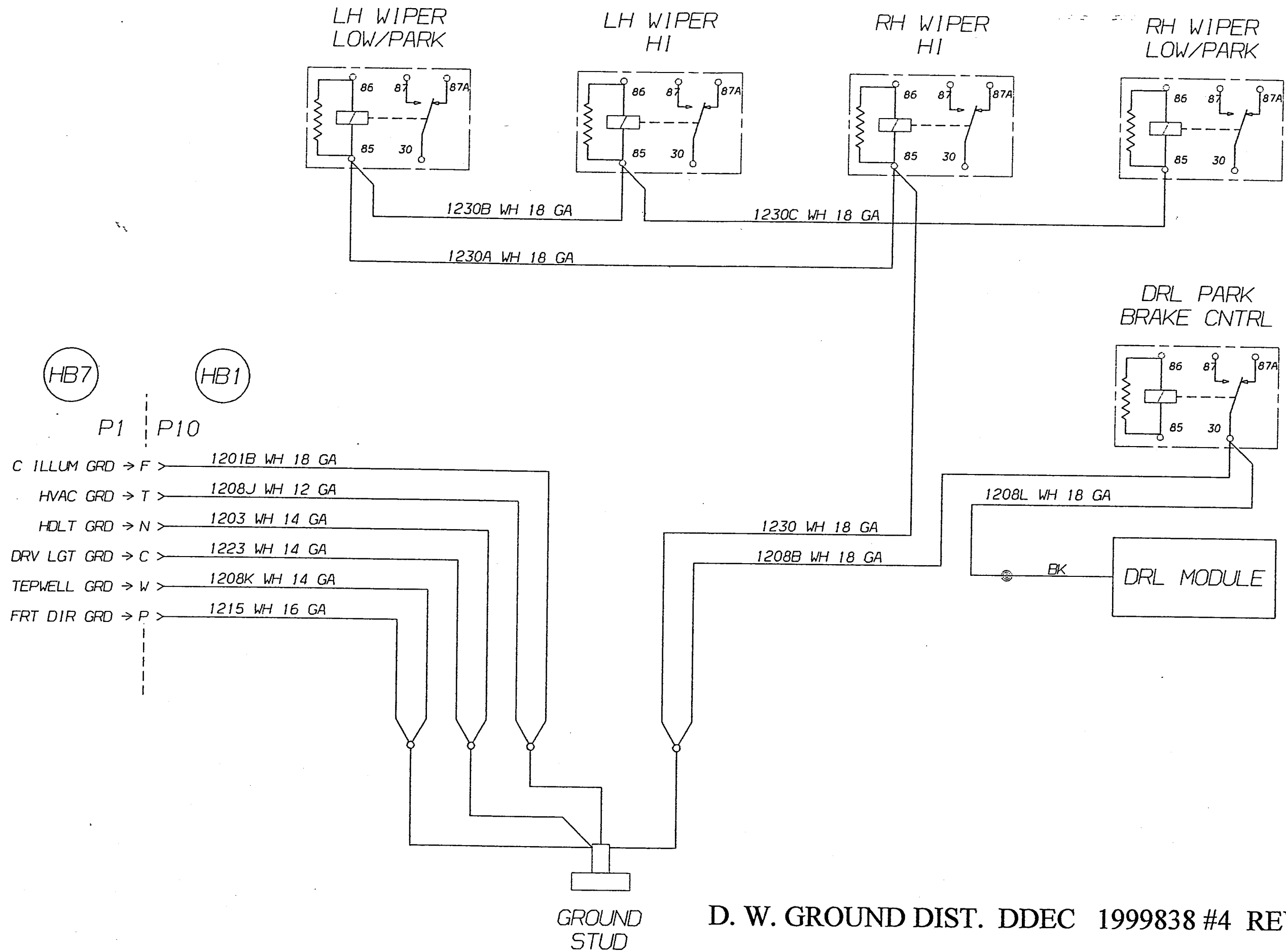

D. W. GROUND DIST. DDEC 1999838 #4 REV. C

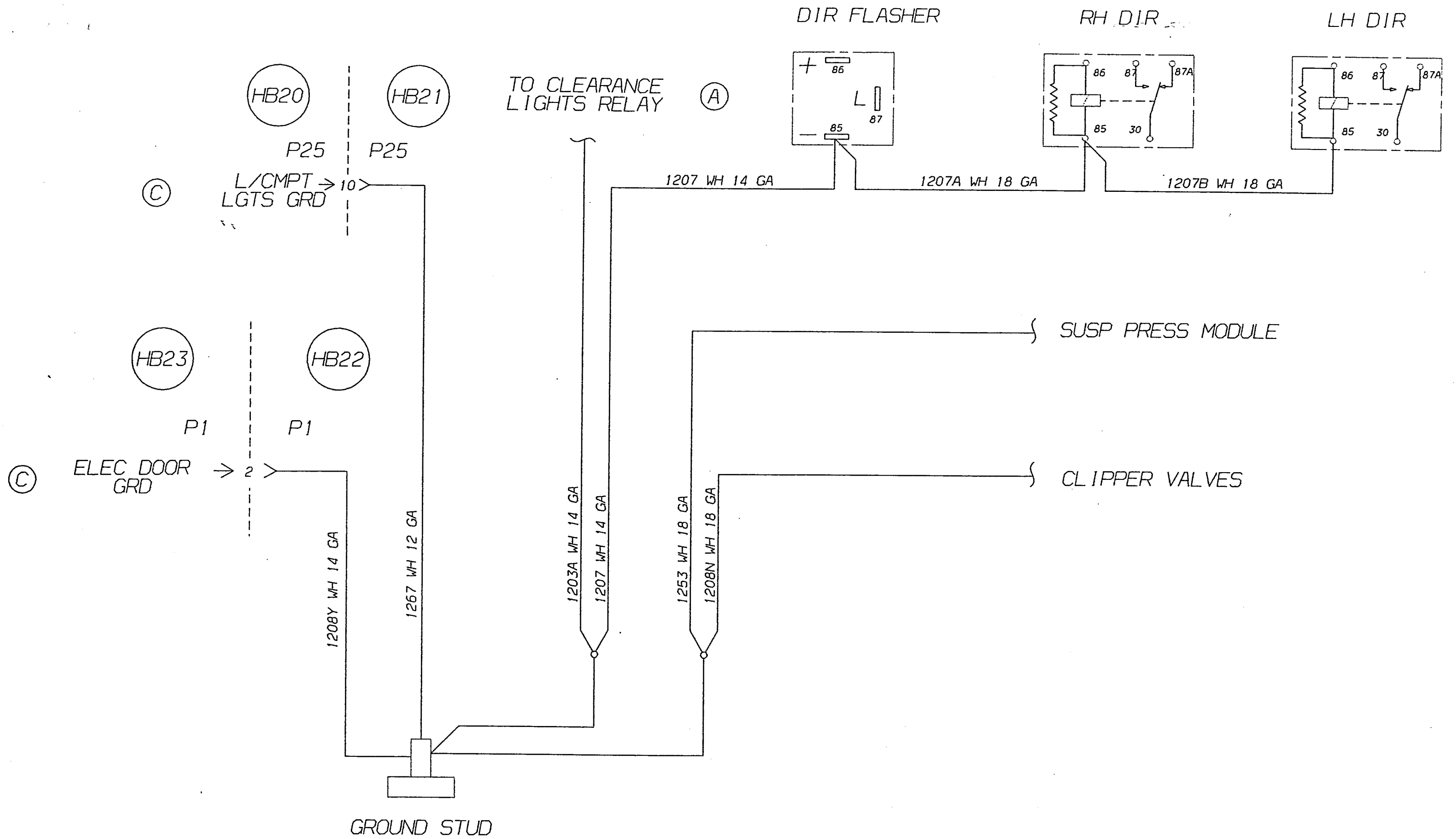

D. W. GROUND DIST. DDEC 1999838 #5 REV. C

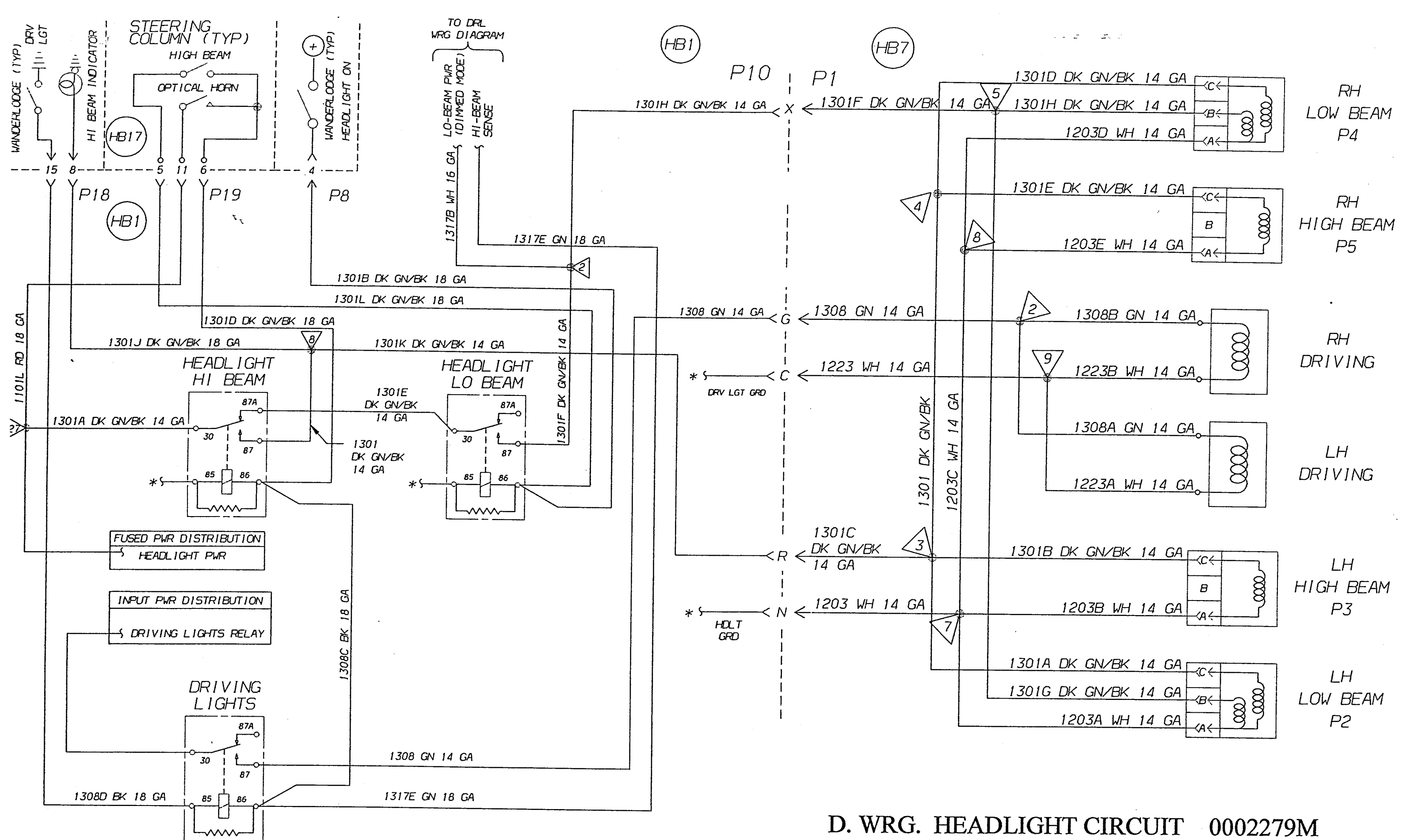

D. WRG. HEADLIGHT CIRCUIT 0002279M

HEADLIGHT SWITCH (TYP)

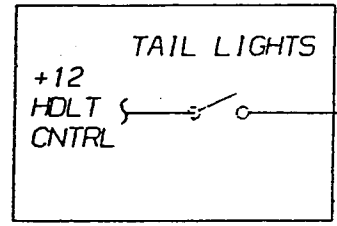

HB1

P8

1315B BN 16 GA

P5

CLEARANCE LIGHTS

WANDERLODGE

HB7

P1

P10

1315C BN 16 GA

HVAC ILLUM

P6

1304 GN 16 GA

P5

1315A BN 16 GA

P9

P1

1315A BN 14 GA

P2

P1

1315 BN 14 GA

HB2

HB3

1315B BN 14 GA

1315C BN 14 GA

1315D BN 14 GA

TAIL STOP RH DIR

RH STOP/TAIL

STOP TAIL STOP BACK-UP

RH BELTLINE GRD (SEE STOPLIGHT WRG DIAGRAM)

LICENSE PLATE LGTS

1315J BN 14 GA 1216N WH 14 GA

1315K BN 14 GA 1216P WH 14 GA

1315H BN 14 GA

LH DIR STOP TAIL

LH STOP/TAIL

BACK-UP STOP TAIL STOP

1315E BN 14 GA

1315G BN 14 GA

LH BELTLINE GRD

1216M WH 14 GA

(SEE STOPLIGHT WRG DIAGRAM)

1203B WH 18 GA

1310C DK GN/BK 18 GA (M11)

1315E DK GN/BK 18 GA (DDEC)

CLEARANCE LIGHT RELAY

MIRROR SW ILLUM RELAY

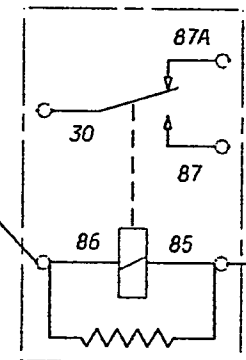
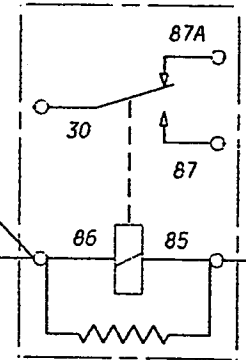

SEE GROUND DISTRIBUTION WRG DIAGRAM

D. WRG. TAIL LIGHTS 0010389M RVE.B