

AIR COMPRESSORS (Section 7)

Tu-Flo 501 Air Compressor

Assembly	7-10
Cleaning of Parts	7-8
Description and Operation	7-3
Cooling	7-5
Intake and Compression (Loaded)	7-4
Lubrication	7-5
Non-Compression (Unloaded)	7-4
General Service Checks	7-6
Air Leakage Tests	7-7
Inspection	7-6
Operating Tests	7-6
Inspection of Parts	7-8
Inspection of Rebuilt Unit	7-12
Preventive Maintenance	7-5
Removing and Disassembly	7-7
Repairs	7-9
Tabulated Data	7-12
Troubleshooting	7-12
Assembly	7-18

Tu-Flo 700 Air Compressor

Cleaning of Parts	7-17
Description	7-13
General Service Checks	7-15
Air Leakage Tests	7-16
Inspection	7-15
Operating Tests	7-15
Inspection of Parts	7-17
Inspection of Rebuilt Unit	7-19
Operation	7-13
Cooling	7-14
Intake and Compression (Loaded)	7-13
Lubrication	7-14
Non-Compression (Unloaded)	7-14
Preventive Maintenance	7-14
Removing and Disassembly	7-16
Repairs	7-18
Specifications	7-20
Testing Rebuilt Compressor	7-19
Troubleshooting	7-20

IMPORTANT! PLEASE READ

When working on or around air brake systems and components, the following precautions should be observed:

1. Always block vehicle wheels. Stop engine when working under a vehicle. Depleting vehicle air system pressure may cause vehicle to roll. Keep hands away from chamber push rods and slack adjusters; they may apply as system pressure drops.
2. Never connect or disconnect a hose or line containing air pressure. It may whip as air escapes. Never remove a component or pipe plug unless you are certain all system pressure has been depleted.
3. Never exceed recommended air pressure and always wear safety glasses when working with air pressure. Never look into air jets or direct them at anyone.
4. Never attempt to disassemble a component until you have read and understand recommended procedures. Some components contain powerful springs and injury can result if not properly disassembled. Use only proper tools and observe all precautions pertaining to use of those tools.

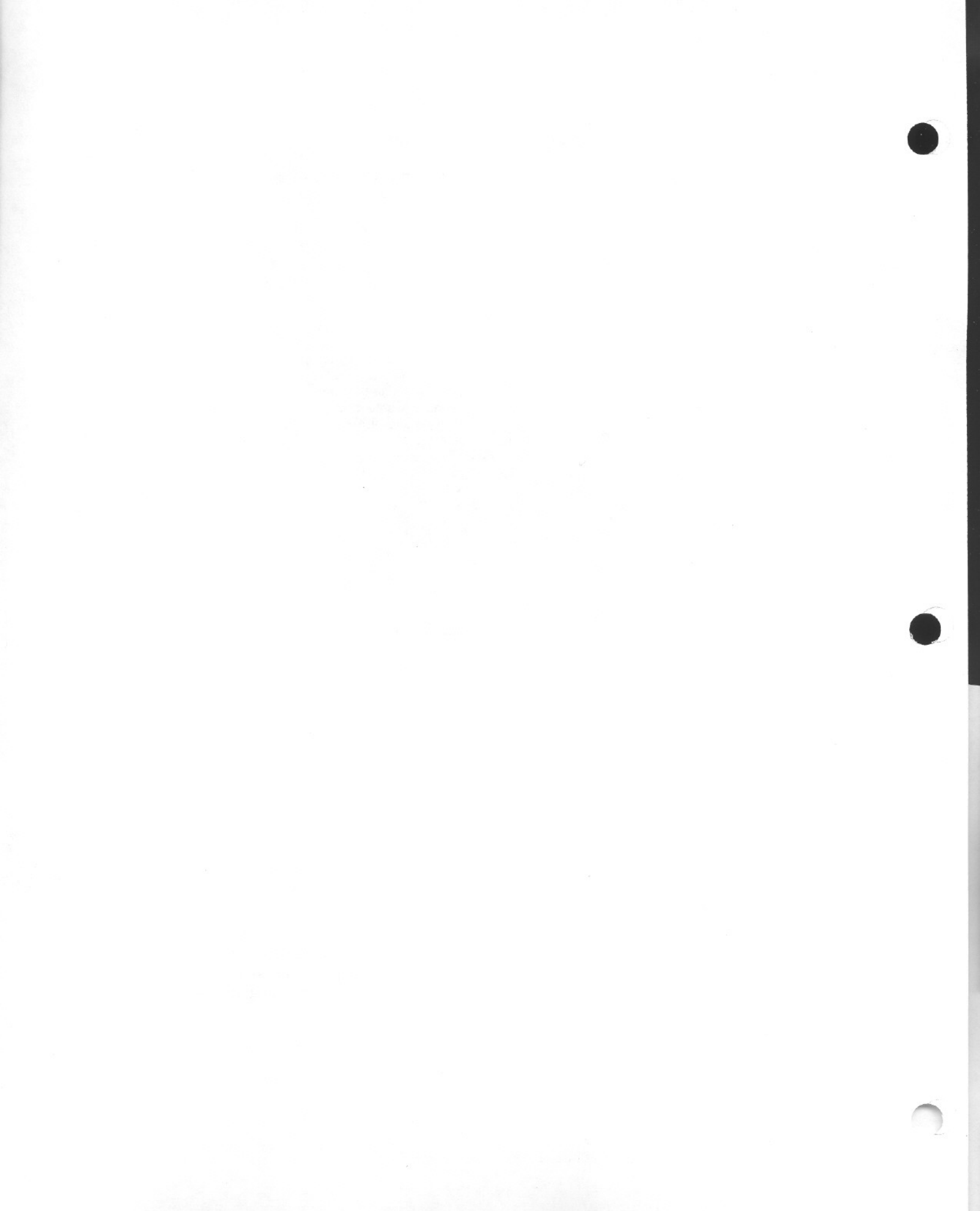



Heavy Vehicle
Systems Group

Service Data

SD-01-3

Formerly SD-64

TU-FLO 501 AIR COMPRESSOR

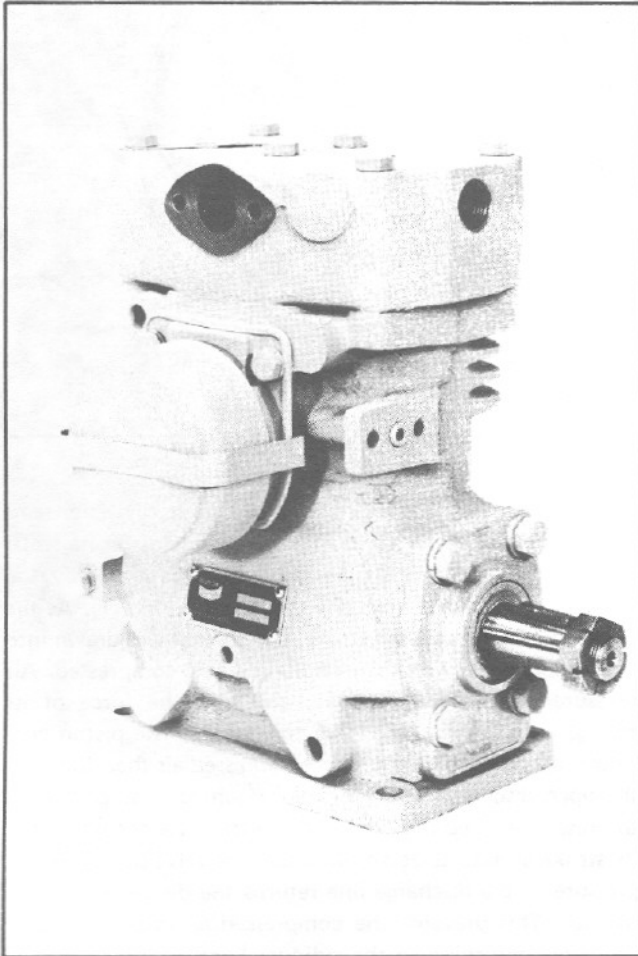

DESCRIPTION AND OPERATION

General

The function of the air compressor is to provide and maintain air under pressure to operate devices in the air brake and/or auxiliary air systems.

Description

The Tu-Flo 501 is a two cylinder, single stage, reciprocating compressor with a rated displacement of 12 cubic feet of air per minute at 1250 R.P.M.

The Tu-Flo 501 is constructed from two major assemblies, the head and the crankcase. The head houses the discharge valving and is installed on the upper portion of the crankcase. The crankcase is a one piece casting combining the cylinder block and the crankcase. The upper portion of the casting houses the cylinder bores and inlet valving; and the lower portion, the crankshaft and main bearings. Various mounting and drive configurations, required by the numerous vehicle engine designs, are obtained by bolting different mounting flanges, end covers, and base adapters to the crankcase. Two horizontal governor mounting pads are located on either side of the upper portion of the crankcase to provide convenient governor mounting.

Two methods are employed for cooling the Tu-Flo 501 during operation. The cylinder head is connected to the engine's cooling system, while the cylinder bore portion of the crankcase has external fins for efficient air cooling.

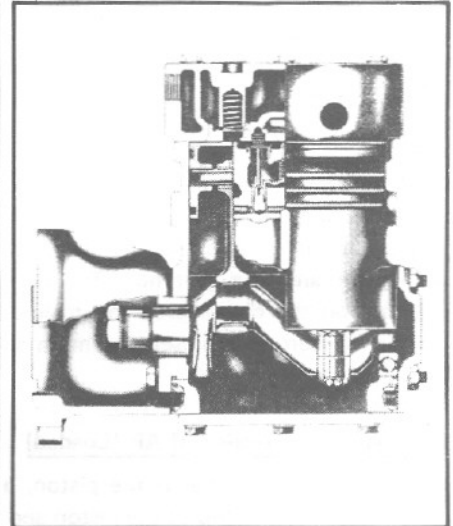
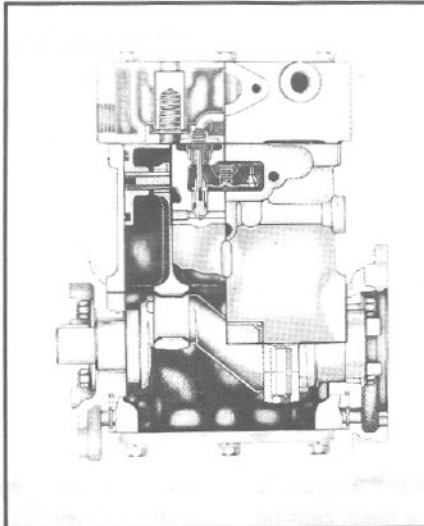
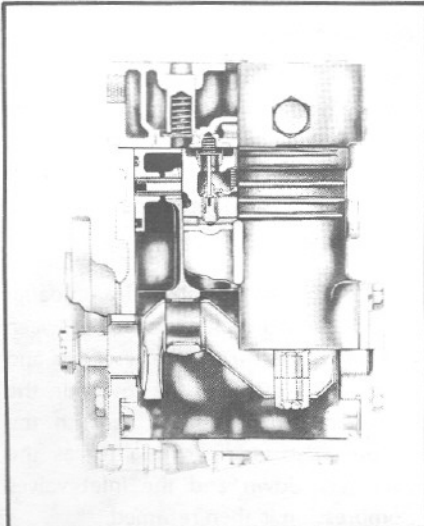

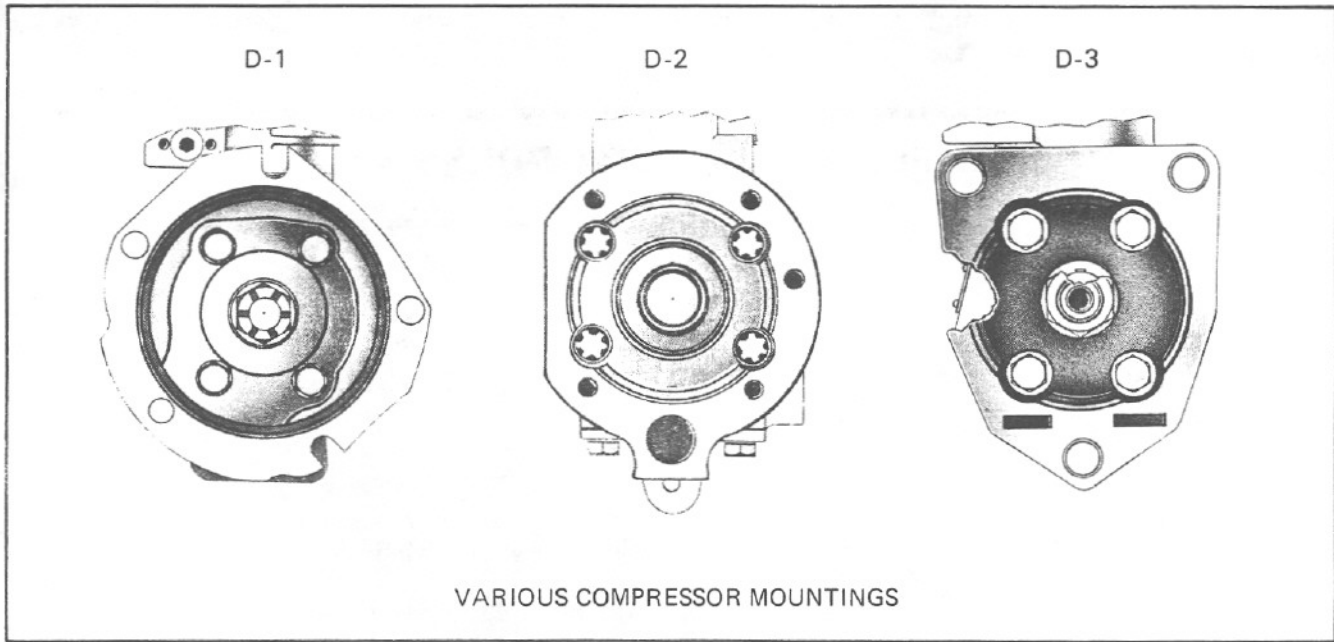

All Tu-Flo 501 compressors utilize the engine's pressurized oil system to lubricate the internal moving parts.

A nameplate is attached to the crankcase to identify the compressor. The nameplate displays a Bendix piece number or in some cases an engine or vehicle manufacturer's piece number, along with a serial number.

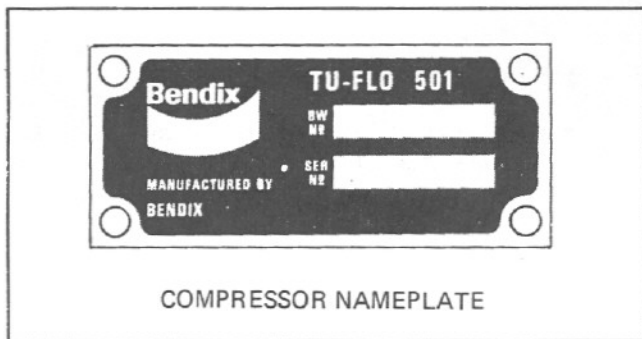

OPERATION

General

The compressor is driven by the vehicle engine and is operating continuously while the engine is running. Actual compression of air is controlled by the compressor unloading mechanism and the governor. The governor is generally mounted on the compressor and maintains the brake system air pressure to a preset maximum and minimum pressure level.

Intake and Compression of Air (Loaded)

During the down stroke of the piston, a slight vacuum is created between the top of the piston and the head, causing

the flat circular inlet valve to move up and off its seat. (Note the flat square discharge valve remains on its seat.) Atmospheric air is drawn through the air strainer by the open inlet valve and into the cylinder (see Fig. 1). As the piston begins its upward stroke, the air that was drawn into the cylinder on the down stroke is being compressed. Air pressure on top of the inlet valve plus the force of its spring, returns the inlet valve to its seat. The piston continues the upward stroke and compressed air then flows by the open discharge valve, into the discharge line and on to the reservoirs (see Fig. 2). As the piston reaches the top of its stroke and starts down, the discharge valve spring and air pressure in the discharge line returns the discharge valve to its seat. This prevents the compressed air in the discharge line from returning to the cylinder bore as the intake and compression cycle is repeated.

Non-Compression of Air (Unloaded)

When air pressure in the reservoir reaches the cut-out setting of the governor, the governor allows air to pass from the reservoir into the cavity beneath the unloader pistons. This lifts the unloader pistons and plungers. The plungers move up and hold the inlet valves off their seats (see Fig. 3).

With the inlet valves held off their seats by the unloader pistons and plungers, air is pumped back and forth between the two cylinders. When air is used from the reservoir and the pressure drops to the cut-in setting of the governor, the governor closes and exhausts the air from beneath the unloader pistons. The unloader saddle spring forces the saddle, pistons and plungers down and the inlet valves return to their seats. Compression is then resumed.

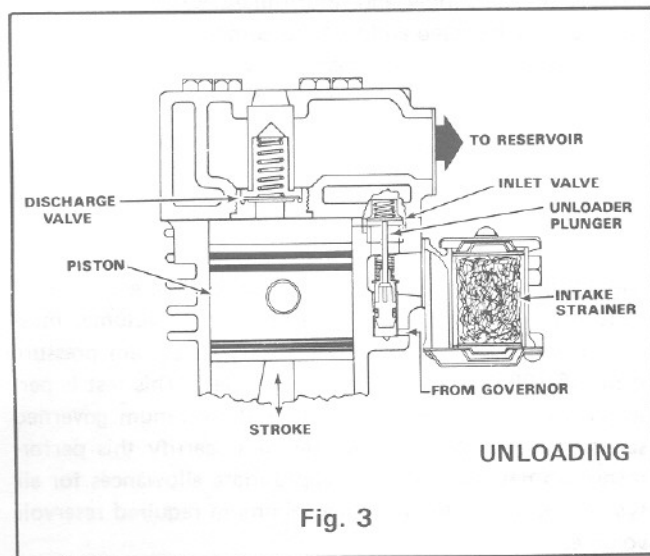
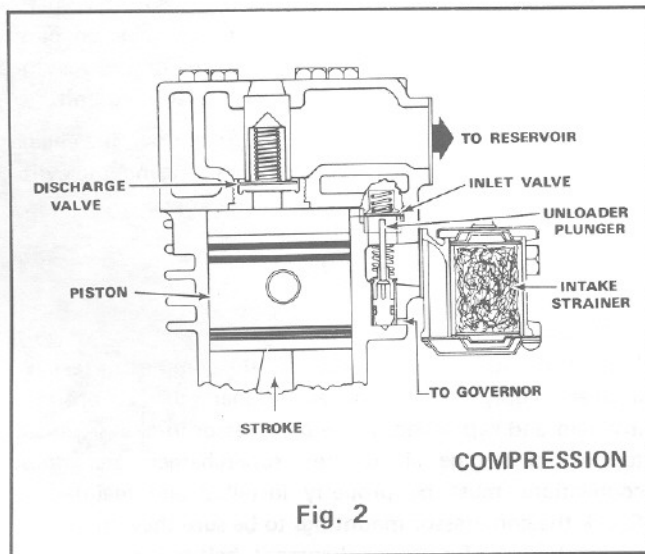
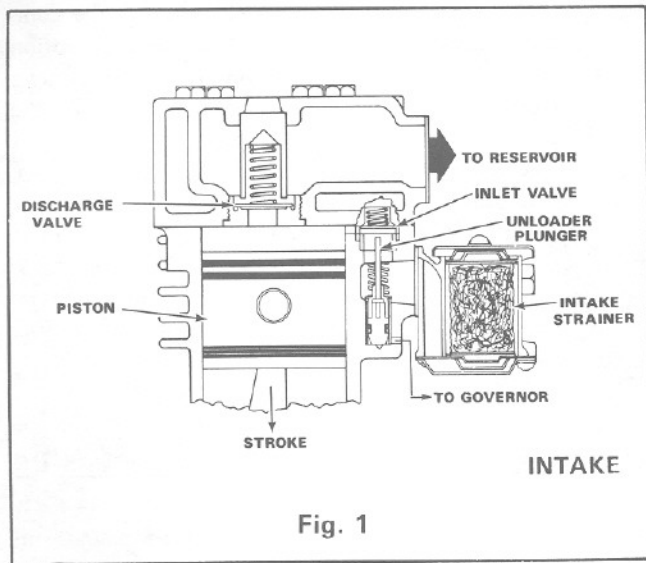

Lubrication

Since all Tu-Flo 501 Compressors are connected to the engine's pressurized oil system, a continuous flow of oil is provided to the compressor, which is eventually returned to the engine.

Oil is fed into the compressor in various ways, for example: through the rear end cover, the drive end of the crankshaft or through the front flange adapter. An oil passage in the crankshaft conducts pressurized oil to the precision sleeve main bearings and to the connecting rod bearings. Splash lubrication of the cylinder bores, connecting rod wrist pin bushings, and the ball type main bearings, on some models, is obtained as oil is forced out around the crankshaft journals by engine oil pressure.

Cooling

Air flowing through the engine compartment from the action of the engine's fan and the movement of the vehicle assists in cooling the crankcase. Coolant flowing from the engine's cooling system through connecting lines enters the head and passes through the head's water jacket and back to the engine. Proper cooling is important in maintaining discharge air temperatures below the maximum 400°F recommended.

PREVENTIVE MAINTENANCE

Every month, 300 operating hours or after each 10,000 miles, depending on the operating conditions, experience and the type of strainer used, service the air strainer.

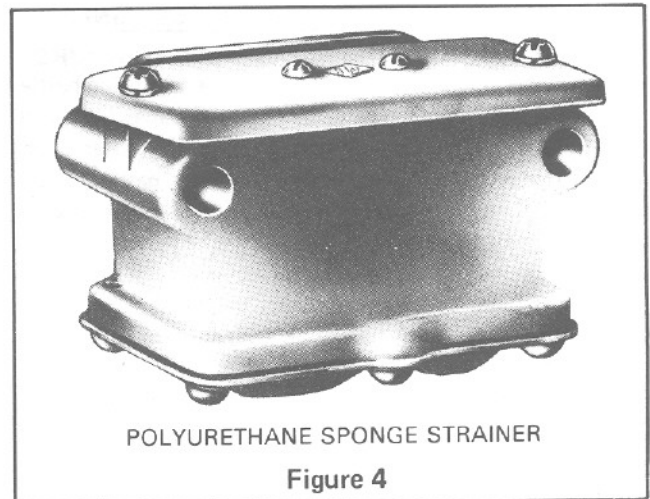

POLYURETHANE SPONGE STRAINER

EVERY 5000 MILES ON 150 OPERATING HOURS
Remove and wash all of the parts. The strainer element should be cleaned or replaced. If the element is cleaned, it should be washed in a commercial solvent or a detergent and water solution. The element should be saturated in clean engine oil, then squeezed dry before replacing it in the strainer. Be sure to replace the air strainer gasket if the entire air strainer is removed from the compressor intake.

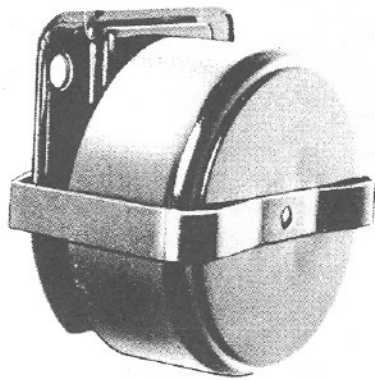

PAPER AIR STRAINER
DRY ELEMENT-PLEATED
Figure 5

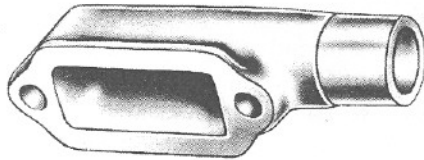

COMPRESSOR INTAKE ADAPTER
Figure 6

DRY ELEMENT – PLEATED PAPER AIR STRAINER

EVERY 20,000 MILES OR 800 OPERATING HOURS

Remove the spring clips from either side of mounting baffle and remove the cover. Replace the pleated paper filter and remount the cleaned cover making sure the filter is in position. Be sure to replace the air strainer gasket if the entire air strainer is removed from the compressor intake. (NOTE: Some compressors are fitted with compressor intake adapters which allow the compressor intake to be connected to the engine air cleaner.) In this case, the compressor receives a supply of clean air from the engine air cleaner. When the engine air filter is changed, the compressor intake adapter should be checked. If it is loose, remove the intake adapter, clean the strainer plate, if applicable, and replace the intake adapter gasket, and reinstall the adapter securely. Check line connections both at the compressor intake adapter and at the engine air cleaner. Inspect the connecting line for ruptures and replace it if necessary.

EVERY 6 MONTHS, 1800 OPERATING HOURS OR AFTER EACH 50,000 MILES

Remove the discharge head fittings and inspect the compressor discharge port and discharge line for excessive carbon deposits. If excessive buildup is noted in either, the

discharge line must be cleaned or replaced and the compressor checked more thoroughly, paying special attention to the air induction system, oil supply and return system, and proper cooling. If necessary, repair or replace the compressor. Check for proper belt and pulley alignment and belt tension. Adjust if necessary, paying special attention not to over tighten the belt tension. Check for noisy compressor operation, which could indicate a worn drive gear coupling or a loose pulley. Adjust and/or replace as necessary. Check all compressor mounting bolts and retighten evenly if necessary. Check for leakage and proper unloader mechanism operation. Replace if defective in any way.

EVERY 24 MONTHS, 7200 OPERATING HOURS OR AFTER EACH 200,000 MILES

Perform a thorough inspection as indicated below and depending upon the results of this inspection or experience, disassemble the compressor, clean and inspect all parts thoroughly, repair or replace all worn or damaged parts using only genuine Bendix replacements or replace the compressor with a genuine Bendix remanufactured unit.

IMPORTANT – Should it be necessary to drain the engine cooling system to prevent damage from freezing, the cylinder head of the compressor must also be drained.

GENERAL SERVICE CHECKS

Inspection

It is of the utmost importance that the compressor receives a clean supply of air. The air strainer must be properly installed and kept clean. If the compressor intake is connected to the engine air cleaner, supercharger, etc., these connections must be properly installed and maintained. Check the compressor mountings to be sure they are secure. Check the drive for proper alignment, belt tension, etc.

Inspect the oil supply and return lines. Be sure these lines are properly installed and that the compressor is getting the proper supply of oil, and just as important, that the oil is returning to the engine. Check the coolant lines to and from the compressor and see that the cooling fins on the crankcase are not clogged with dirt, grease, etc. Check the unloader mechanism for proper and prompt operation.

Operating Tests

Vehicles manufactured after the effective date of FMVSS 121, with the minimum required reservoir volume, must have a compressor capable of raising air system pressure from 85-100 P.S.I. in 25 seconds or less. This test is performed with the engine operating at maximum governed speed. The vehicle manufacturer must certify this performance on new vehicles with appropriate allowances for air systems with greater than the minimum required reservoir volume.

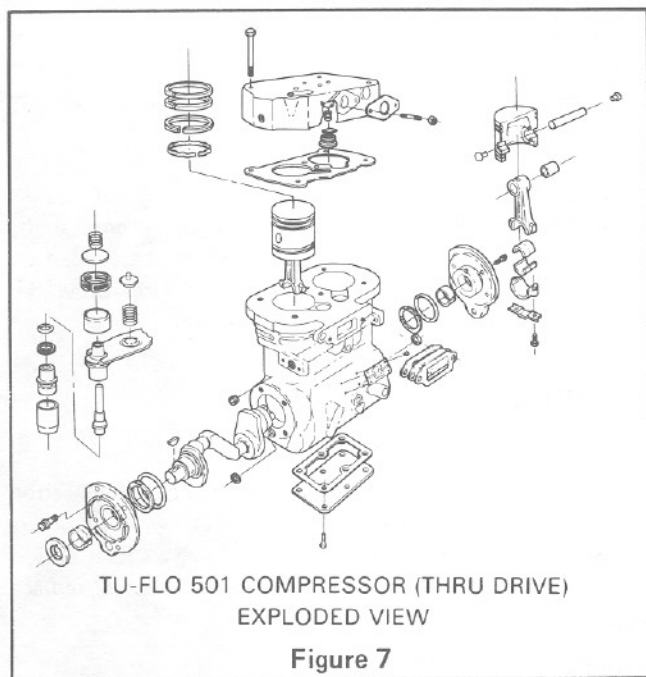

Air Leakage Tests

Leakage past the discharge valves can be detected by removing the discharge line, applying shop air back through the discharge port and listening for escaping air. Also, the discharge valves and the unloader pistons can be checked for leakage by building up the air system until the governor cuts out, then stopping the engine. With the engine stopped, listen for escaping air at the compressor intake. To pinpoint leakage if noted, apply a small quantity of oil around the unloader pistons. If there is no noticeable leakage at the unloader pistons, the discharge valves may be leaking. If the compressor does not function as described above, or leakage is excessive, it is recommended that it be returned to the nearest authorized Bendix Distributor for a factory remanufactured compressor. If this is not possible, the compressor can be repaired using genuine Bendix replacement parts, in which case, the following information should prove helpful.

REMOVING AND DISASSEMBLY

Removing

These instructions are general and are intended to be a guide, in some cases additional preparations and precautions are necessary. Chock the wheels of the vehicle and drain the air pressure from all the reservoirs in the system. Drain the engine cooling system and the cylinder head of the compressor. Disconnect all air, water and oil lines leading to and from the compressor. Remove the drive gear(s) or pulley from the compressor crankshaft using a gear puller. Inspect the pulley or gear and associated parts for visible wear or damage. Since these parts are precision fitted, they must be replaced if they are worn or damaged.

DISASSEMBLY

General

Remove road dirt and grease from the exterior of the compressor with a cleaning solvent. Before the compressor is disassembled, the following items should be marked to show their relationship when the compressor is assembled. Mark both the front and rear end cover in relation to the crankcase. Mark the drive end of the crankshaft in relation to the front end cover and the crankcase. Mark the cylinder head in relation to the crankcase. Mark the base plate or base adapter in relation to the crankcase.

A convenient method to indicate the above relationship is to use a metal scribe to mark the parts with numbers or lines. Do not use a marking method that can be wiped off or obliterated during rebuilding, such as chalk. Remove all compressor attachments such as governors, air strainers or inlet fittings, discharge fittings and pipe plugs.

Cylinder Head

Remove the six cylinder head cap screws and tap the head with a soft mallet to break the gasket seal. Remove the inlet valve springs from the head and inlet valves from their guides in the crankcase. Remove inlet valve guides from around the inlet valve seats on the crankcase taking care not to damage seats. Scrape off any gasket material from the cylinder head and crankcase. Unscrew the discharge valve seats from the head and remove the discharge valves and springs. Inspect the discharge valve seats for nicks, cracks, and excessive wear and replace if necessary.

The discharge valve stops should be inspected for wear and replaced if excessive peening has occurred. To determine if excessive peening has occurred, measure the discharge valve travel. Discharge valve travel must not exceed .057 inches. To remove the discharge valve stops, support the machined surface of the cylinder head on an arbor press bed and gently press the stops from the top of the head and out the bottom. Be sure to allow sufficient clearance for the stops between the press bed and the bottom of the cylinder head. The valve stop bores in the cylinder head must be inspected for excessive scoring. A new head body must be used if scoring is excessive. Discard the inlet valves and springs, the discharge valves and springs and the discharge valve seats if defective.

Crankcase Base Plate or Adapter

Remove the cap screws securing the base plate or base adapter. Tap with soft mallet to break the gasket seal. Scrape off any gasket material from crankcase and plate or adapter.

Connecting Rod Assemblies

(Note: Before removing the connecting rods, mark each connecting rod and its cap. Each connecting rod is matched

to its own cap for proper bearing fit, and these parts must not be interchanged.) Straighten the prongs of the connecting rod bolt lock strap and remove the bolts and bearing caps. Push the piston with the connecting rods attached out the top of the cylinders of the crankcase. Replace the bearing caps on their respective connecting rods. Remove the piston rings from the pistons. If the pistons are to be removed from the connecting rods, remove the wrist pin lock wires or teflon plugs and press the wrist pins from the pistons and connecting rods.

If the pistons are removed from the rod, inspect the bronze wrist pin bushing. Press out and replace the bushing if it is excessively worn. (See inspection of Parts) Discard the piston rings and the connecting rod journal bearings. Discard the wrist pin bushings if they were removed.

Crankcase

Remove the key or keys from the crankshaft and any burrs from the crankshaft where the key or keys were removed. (Note: Through Drive Compressors may have a crankshaft key at both ends.) Remove the four cap screws securing front or drive-end end cover or flange adapter. Remove the end cover, taking care not to damage the crankshaft oil seal or front main bearing, if any. Remove both of the small seal rings from the crankcase, and the O-Ring from around the front end cover. Remove the four cap screws securing the rear end cover and remove the rear end cover taking care not to damage the rear main bearing, if any. Remove both of the small seal rings from the crankcase and the O-Ring from around the end cover. If the compressor has ball type main bearings, press the crankshaft and ball bearings from the crankcase, then press the ball bearings from the crankshaft. Remove the unloader spring, spring saddle, and spring seat from the inlet cavity of the crankcase, using long nose pliers. Remove the unloader plungers and guides. Cover the inlet cavity with a shop rag and apply air pressure to the governor mounting pad unloader port to blow the unloader pistons out of their bores and into the inlet cavity.

CLEANING OF PARTS

General

All parts should be cleaned in a good commercial grade solvent and dried prior to inspection.

Cylinder Head

Remove all the carbon deposits from the discharge cavities and all the rust and scale from the cooling cavities of the cylinder head body. Scrape all the foreign matter from the body surfaces and use shop air pressure to blow the dirt particles from all the cavities.

Crankcase

Clean the carbon and dirt from the inlet and unloader passages. Use shop air pressure to blow the carbon and dirt deposits from the unloader passages.

Oil Passages

Thoroughly clean all oil passages through the crankshaft, crankcase, end covers, and base plate or base adapter. Inspect the passages with a wire to be sure. Blow the loosened foreign matter out with air pressure.

INSPECTION OF PARTS

Cylinder Head Body

Inspect the cylinder head for cracks or damage. Apply shop air pressure to one of the coolant ports with all others plugged, and check for leakage by applying a soap solution to the exterior of the body. If leakage is detected, replace the head.

End Covers

Check for cracks and external damage. If the crankshaft main bearings are installed in the end cover, check for excessive wear and flat spots and replace them if necessary. If the compressor has an oil seal in the end cover, it should be removed by pressing it out of the end cover.

Crankcase

Check all crankcase surfaces for cracks and damage. On compressors where ball bearing main bearings are used the difference between the O.D. of the outer race and the I.D. of the crankcase hole should be .0000 in. to .0015 in. loose. This is to maintain the correct press fit. The crankcase must be replaced if the fit is too loose.

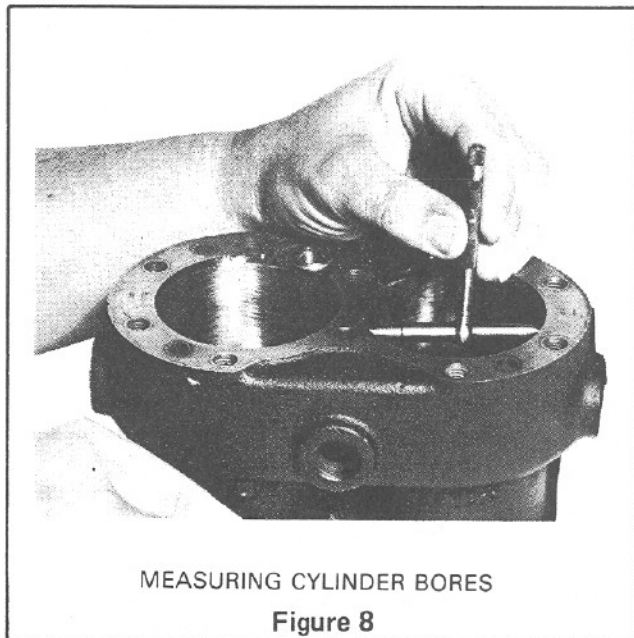

MEASURING CYLINDER BORES

Figure 8

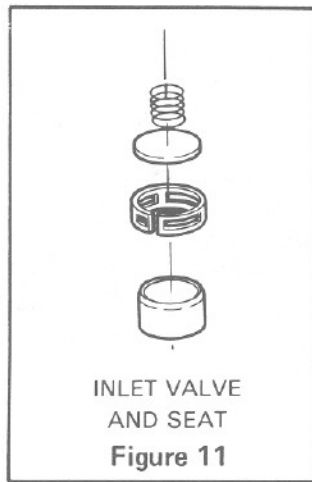
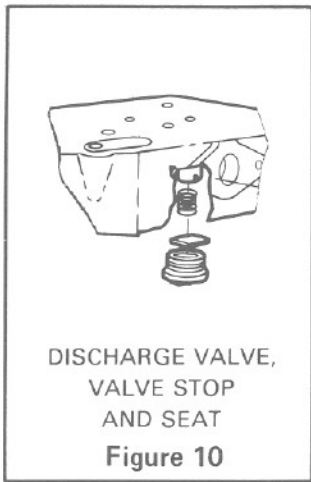

Inlet Valves and Seats

Inlet valves and springs should be replaced, if the inlet valve seats show signs of slight nicks or scratches. They can be redressed with a fine piece of emery cloth or by lapping with a lapping stone, grinding compound and grinding tool. If the seats are damaged to the extent that they cannot be reclaimed, they must be replaced. The dimension from the top of the cylinder block to the inlet valve seat should not exceed .113 in. nor be less than .101 in.

ASSEMBLY

General Note: All torques specified in this manual are **assembly** torques and can be expected to fall off after assembly is accomplished. **Do not retorquer** after initial assembly torques fall.

To convert inch pounds of torque to foot pounds of torque, divide inch pounds by 12.

$$\frac{\text{inch pounds}}{12} = \text{foot pounds}$$

To convert foot pounds of torque to inch pounds of torque, multiply foot pounds by 12.

$$\text{foot pounds} \times 12 = \text{inch pounds}$$

Installing the Crankshaft

Cautionary Note:

All flange mounted compressors **must be assembled without** a gasket between the crankcase and flange adapter and some compressors do not require gaskets on the end cover. Install the new crankcase gaskets **only** where they were removed during disassembly. In service failure of the compressor will occur if gaskets are used in disregard of the preceding.

If the compressor uses a ball type main bearing, press the ball bearing onto the correct end of the crankshaft. Position the ball bearing and the crankshaft in the crankcase, making sure the drive end of the crankshaft is positioned in the

crankcase as marked before disassembly. Carefully press the crankshaft and ball bearing into the crankcase using an arbor press.

In the case of compressors with a front ball bearing, place two small seal rings in the counter-sunk holes at the front of the crankcase, as well as an end cover gasket. Install the front end cover in the proper position as marked before disassembly, taking care not to damage the new oil seal.

In the case of compressors with a rear ball bearing, place two small seal rings in the counter-bore at the rear of the crankcase. In one case a gasket is used and in another a large O-Ring is placed in the counterbore at the rear of the crankcase. These are in addition to the seal rings. Install the rear end cover in the proper position as marked before disassembly. Since June, 1978, the two small seal rings have been increased slightly in cross section and a retaining ring added, as shown in Figure 12.

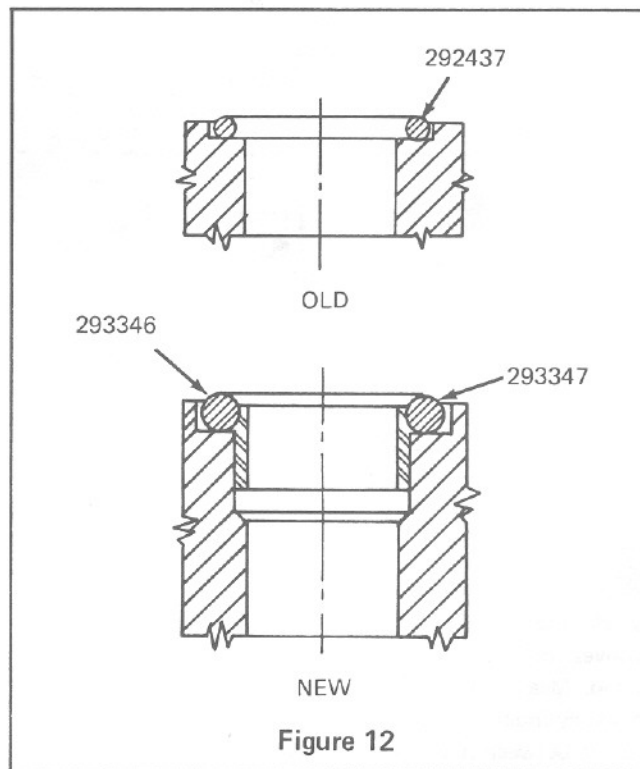

In the case of compressors with a sleeve bearing either front or rear, place the two small seal rings in the counter-sunk holes in the crankcase. **Caution:** An end cover gasket must not be used. Place the O-Ring seal in the groove around the flange adapter or the end cover, and affix the thrust washer. Install the flange adapter or end cover in the proper position as marked before disassembly, taking care not to damage the sleeve bearing.

Secure the flange adapter, front or rear end cover to the crankcase by tightening the four cap screws. See note below for torque.

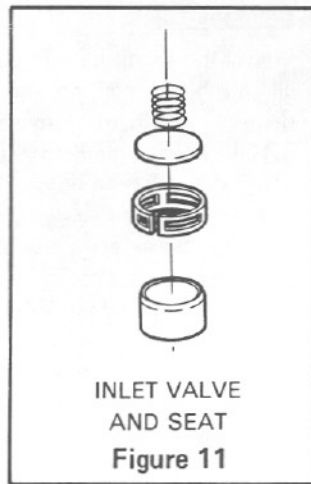
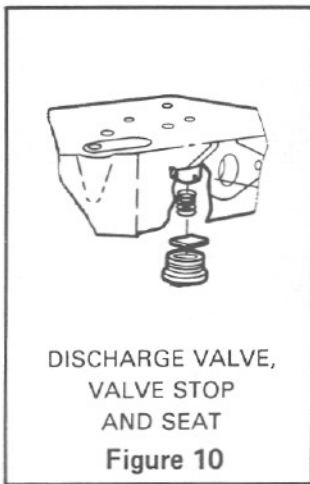

Inlet Valves and Seats

Inlet valves and springs should be replaced, if the inlet valve seats show signs of slight nicks or scratches. They can be redressed with a fine piece of emery cloth or by lapping with a lapping stone, grinding compound and grinding tool. If the seats are damaged to the extent that they cannot be reclaimed, they must be replaced. The dimension from the top of the cylinder block to the inlet valve seat should not exceed .113 in. nor be less than .101 in.

ASSEMBLY

General Note: All torques specified in this manual are assembly torques and can be expected to fall off after assembly is accomplished. **Do not retorque** after initial assembly torques fall.

To convert inch pounds of torque to foot pounds of torque, divide inch pounds by 12.

$$\frac{\text{inch pounds}}{12} = \text{foot pounds}$$

To convert foot pounds of torque to inch pounds of torque, multiply foot pounds by 12.

$$\text{foot pounds} \times 12 = \text{inch pounds}$$

Installing the Crankshaft

Cautionary Note:

All flange mounted compressors **must be assembled without** a gasket between the crankcase and flange adapter and some compressors do not require gaskets on the end cover. Install the new crankcase gaskets **only** where they were removed during disassembly. In service failure of the compressor will occur if gaskets are used in disregard of the preceding.

If the compressor uses a ball type main bearing, press the ball bearing onto the correct end of the crankshaft. Position the ball bearing and the crankshaft in the crankcase, making sure the drive end of the crankshaft is positioned in the

crankcase as marked before disassembly. Carefully press the crankshaft and ball bearing into the crankcase using an arbor press.

In the case of compressors with a front ball bearing, place two small seal rings in the counter-sunk holes at the front of the crankcase, as well as an end cover gasket. Install the front end cover in the proper position as marked before disassembly, taking care not to damage the new oil seal.

In the case of compressors with a rear ball bearing, place two small seal rings in the counter-bore at the rear of the crankcase. In one case a gasket is used and in another a large O-Ring is placed in the counterbore at the rear of the crankcase. These are in addition to the seal rings. Install the rear end cover in the proper position as marked before disassembly. Since June, 1978, the two small seal rings have been increased slightly in cross section and a retaining ring added, as shown in Figure 12.

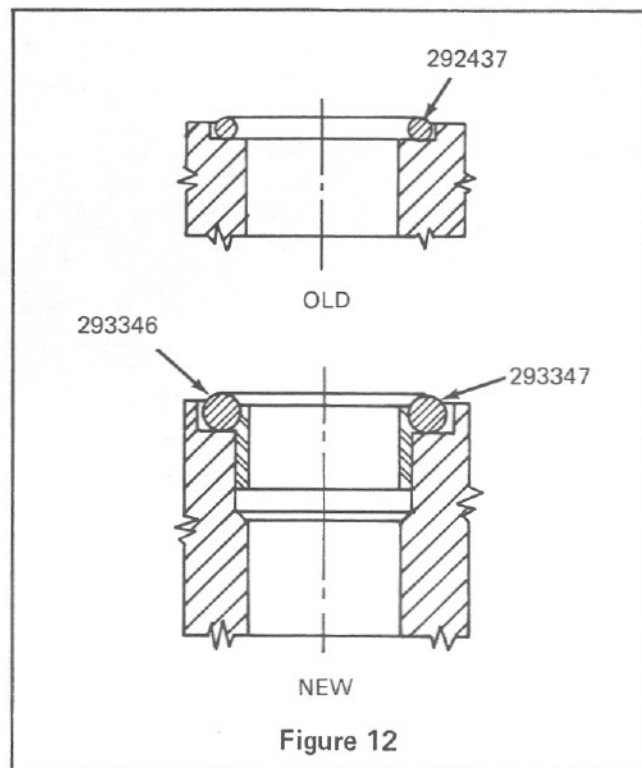

In the case of compressors with a sleeve bearing either front or rear, place the two small seal rings in the counter-sunk holes in the crankcase. **Caution:** An end cover gasket must not be used. Place the O-Ring seal in the groove around the flange adapter or the end cover, and affix the thrust washer. Install the flange adapter or end cover in the proper position as marked before disassembly, taking care not to damage the sleeve bearing.

Secure the flange adapter, front or rear end cover to the crankcase by tightening the four cap screws. See note below for torque.

Note: For cast iron flange adapters, torque the four 7/16 in. cap screws to 38-45 foot pounds. For die cast aluminum end covers, torque the four 7/16 in. cap screws to 25-30 foot pounds. All end covers using 5/16 in. cap screws or stud and nuts are torqued to 15-18 foot pounds. For through drive compressors with a cast iron end cover, torque the four 7/16 in. cap screws to 25-30 foot pounds.

Pistons and Connecting Rods

If new wrist pin bushings are to be used, they should be pressed into the connecting rods so that the oil hole in the bushing lines up with the one in the rod. The new bushings should then be reamed or honed to provide between .0001 in. (.00254 mm) and .0006 in. (.01524 mm) clearance on the wrist pin. Position the connecting rod in the piston and press in the wrist pin.

Pistons installed in compressors manufactured prior to November, 1976, will have the wrist pin secured in the piston by a lock wire extending through matching holes in wrist pin and piston boss, anchored in a hole in the side wall of the piston. If the original pistons are used the wrist pin must be pressed in so the hole in the wrist pin aligns with that of the piston and secure same by inserting the new lockwire through the hole in piston and wrist pin and lock the wire by snapping the short 90° section into the lockwire hole in the bottom of the piston.

Compressors built after November, 1976, will have the wrist pin secured by Teflon buttons in either end of the wrist pin, allowing the wrist pin to float. The Teflon buttons pc. no. 292392 may be used with either new or old wrist pins. The later design pistons have two rings above the wrist pin and one below. Install the piston rings in the correct location with the ring pipemarks up. Stagger the position of the ring gaps. Prelubricate the piston, piston rings, wrist pins and connecting rod.

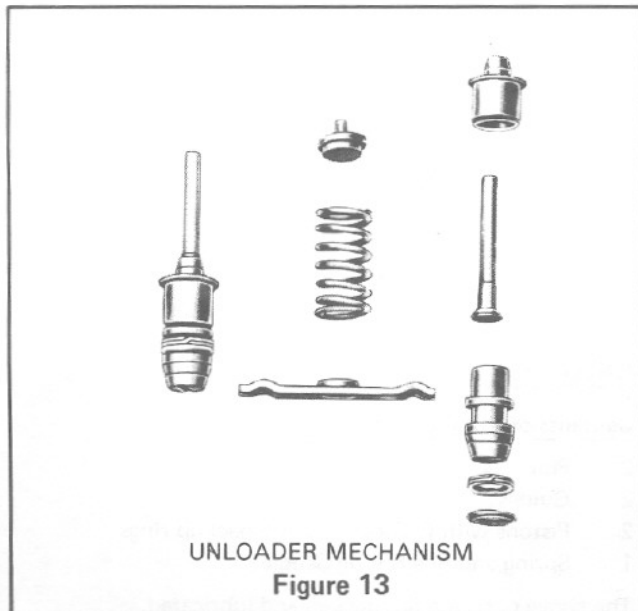

Unloader

A new unloader kit should be used when rebuilding. (Figure 13). (Piece Number 279615). The unloader pistons in the kit are prelubricated with a special lubricant piece number 239379 and need no additional lubrication. Install the unloader pistons in their bores being careful not to cut the o-rings or distort the back-up rings. Position the unloader plungers in their guides and slip them in and over the tops of the pistons. Install the unloader spring seat in the crankcase inlet cavity; a small hole is drilled in the crankcase for this purpose. Position the saddle between the unloader piston guides, so its forks are centered on the guides. Install the unloader spring, making sure it seats over the spring seats both in the crankcase and on the saddle. Position and install the inlet valve guides, then drop the inlet valves in their guides. The inlet valves should be a loose sliding fit in the guides.

Cylinder Head

Install the inlet valve springs in the cylinder head by applying a turning motion to the spring after it is in the head. The turning motion should dig the spring wire into the spring seat in the bottom of the spring bore in the head. Should this procedure fail after repeated attempts, use a very small quantity of grease to hold them in place, just enough to keep the springs from falling out. Place the cylinder head gasket on the cylinder block. Carefully align the cylinder head assembly on the block and install the cap screws, tightening them evenly to a torque of 25-30 foot pounds.

Base Plate or Base Adapter

Position the base plate or base adapter gasket on the crankcase and install the base plate or base adapter as marked before disassembly. Tighten the six cap screws securing the cast iron base adapter evenly to a torque of 38-45 foot pounds, and 12-16 foot pounds for base plate or aluminum cover.

Testing Rebuilt Compressor

In order to properly test a compressor under operating conditions, a test rack for correct mounting, cooling, lubricating, and driving the compressor is necessary. Such tests are not compulsory if the unit has been carefully rebuilt by an experienced person. A compressor efficiency or build-up test can be run which is not too difficult. An engine lubricated compressor must be connected to an oil supply line of at least 15 P.S.I. pressure during the test and an oil return line must be installed to keep the crankcase drained.

Connect to the compressor discharge port, a reservoir with a volume of 1500 cubic inches, including the volume of connecting line. With the compressor operating at 2100 R.P.M., the time required to raise the reservoir(s) pressure from 85 P.S.I. to 100 P.S.I. should not exceed 7 seconds. During this test, the compressor should be checked for gasket leakage and noisy operation, as well as unloader operation and leakage.

TROUBLE SHOOTING

The following is a listing of the most commonly experienced compressor deficiencies and their probable causes.

Excessive build-up and recovery time:

1. Dirty intake strainer.
2. Restriction in the compressor inlet or discharge lines or cavities.
3. Leaking or broken discharge valves.
4. Drive belt slipping.
5. Inlet valves worn excessively or stuck open.
6. Excessive air system leakage.
7. Excessive wear on piston rings and/or cylinders.

Noisy compressor operation:

1. Loose drive gear or pulley.
2. Excessively worn drive coupling.
3. Worn or burned out bearings.
4. Excessive wear.
5. Improper lubrication to the compressor.
6. Restrictions in the cylinder head or discharge line.

Excessive oil passage:

1. Dirty air strainer.
2. A small, kinked, or restricted oil return line.
3. Back pressure from the engine crankcase.
4. High inlet vacuum at the compressor.
5. Defective oil seal or oil seal ring in the end cover(s).
6. Piston rings improperly installed.
7. Excessive ring or cylinder wear.

Compressor fails to unload:

1. Defective or worn unloader pistons or bores.
2. Defective governor.
3. Unloader line from governor kinked or the cavity beneath the unloader pistons restricted.
4. Unloader mechanism binding or kinked.

INSPECTION OF REBUILT UNIT

Check to be sure that covers, plugs, or masking tape are used to protect all ports if compressor is not to be installed immediately. Fit the end of all crankshafts with keys, nuts, and cotter pins as required and then protect the ends against damage by wrapping with masking tape or friction tape. The open bottom of a vertical engine lubricated compressors should be protected against the entrance of dirt during handling or storage, by installing a temporary cover over the base.

TABULATED DATA

Number of cylinders	2
Bore size	2.625 in.
Stroke	1.50 in.
Piston displacement at 1250 RPM	12 cu. ft.
Piston displacement per revolution	16.5 cu. in.
Maximum recommended RPM (naturally aspirated)	3000
Minimum coolant flow at maximum RPM	2.5 gal./min.
Horsepower required at 3000 RPM against 100 PSI head pressure	4.9 H.P.
Recommended minimum discharge line size	5/8 in. OD Copper Tube
Recommended minimum oil return line size	5/8 in. OD Tubing
Recommended minimum oil supply line size	1/4 in. OD Tubing
Recommended minimum unloader line size	1/4 in. OD Tubing
Recommended minimum inlet cavity line size (when compressor is connected to engine air cleaner)	5/8 in. ID minimum
Recommended minimum coolant line size	1/2 in. OD Tubing
Recommended maximum inlet air temperature	250° F
Recommended maximum discharge air temperature	400° F
Minimum pressure required to unload	60 PSI

COMPLETE FIELD MAINTENANCE KIT NO 287043

Contents of this kit as follows:

1	Unloader mechanism kit
2	Inlet valve guides
2	Inlet valves
2	Inlet valve springs
1	Cylinder head gasket
2	Discharge valves
2	Discharge valve springs
1	Discharge flange gasket
1	Inlet flange gasket
1	Governor flange gasket
1	Filter element
1	Instruction sheet

UNLOADER KIT NO 2796,15

Contents of this kit as follows:

2	Plungers
2	Guides
2	Pistons with O-Ring seals and backup rings
1	Spring and one Spring Saddle

The above parts are pre-packed and lubricated.



Heavy Vehicle
Systems Group

Service Data

SD-01-5

TU-FLO 700 AIR COMPRESSOR

DESCRIPTION

The function of the air compressor is to provide and maintain air under pressure to operate devices in the air brake and/or auxiliary air systems.

The Tu-Flo 700 is a two cylinder single stage, reciprocating compressor with a rated displacement of 15.5 cubic feet of air per minute at 1250 rpm.

The compressor assembly is comprised of three cast iron major sub-assemblies; the cylinder head, the cylinder block and the crankcase.

The cylinder head houses the discharge valving and is installed to the cylinder block. The cylinder block houses the cylinder bores and inlet valves and is installed to the crankcase. The crankcase houses the crankshaft and main bearings.

The Tu-Flo 700 compressor is available in various mounting and drive configurations as required by engine designs. Two (2) convenient governor mounting pads are provided on the block.

The cylinder head and block are cooled by coolant routed to the compressor from the engine cooling system.

Lubrication for the internal parts of the Tu-Flo 700 compressor is provided by the engine's pressurized oil system.

A nameplate, identifying the compressor piece number and serial number, is attached to the side of the crankcase. A nameplate with a black background denotes a new compressor and a red background designates a factory remanufactured unit.

OPERATION

The compressor is driven by the vehicle engine and is operating continuously while the engine is running. Actual compression of air is controlled by the compressor unloading mechanism and the governor. The governor is generally mounted on the compressor and maintains the brake system air pressure to a preset maximum and minimum pressure level.

INTAKE AND COMPRESSION OF AIR (LOADED)

During the down stroke of the piston, a slight vacuum is created between the top of the piston and the head, causing the inlet valve to move up and off its seat. (Note: The discharge valve remains on its seat.) Atmospheric air is drawn through the air strainer by the open inlet valve and

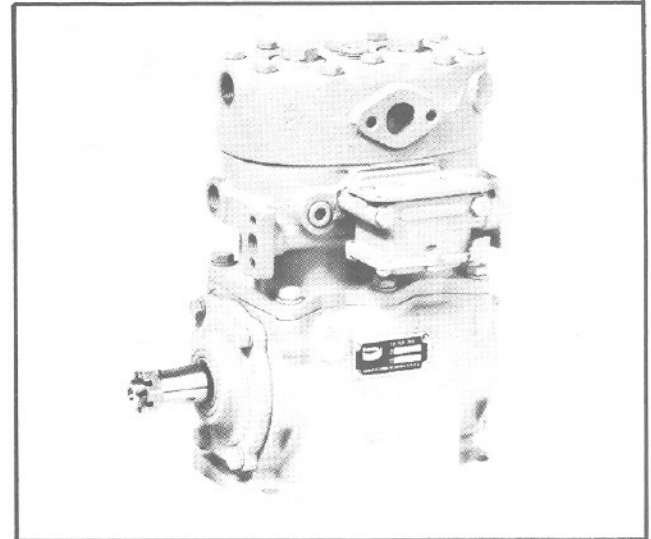

into the cylinder (see Fig. 1). As the piston begins its upward stroke, the air that was drawn into the cylinder on the down stroke is being compressed. Air pressure on top of the inlet valve plus the force of the inlet spring, returns the inlet valve to its seat. The piston continues the upward stroke and compressed air then flows by the open discharge valve, into the discharge line and on to the reservoirs (see Fig. 2). As the piston reaches the top of its stroke and starts down, the discharge valve spring and air pressure in the discharge line returns the discharge valve to its seat. This prevents the compressed air in the discharge line from returning to the cylinder bore as the intake and compression cycle is repeated.

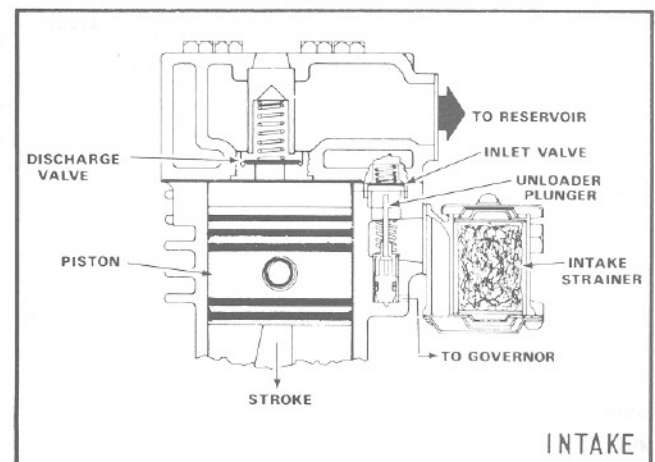

FIGURE 1

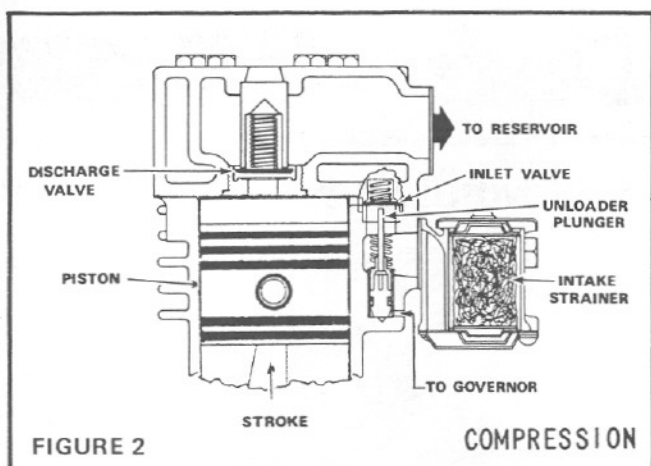

FIGURE 2

NON-COMPRESSION OF AIR (UNLOADED)

When air pressure in the reservoir reaches the cut-out setting of the governor, the governor allows air to pass from the reservoir, through the governor and into the cavity beneath the unloader pistons and plungers. This lifts the unloader pistons and plungers. The plungers move up and hold the inlet valves off their seats (see Fig. 3).

With the inlet valves held off their seats by the unloader pistons and plungers, air is pumped back and forth between the two cylinders. When air is used from the reservoir and the pressure drops to the cut-in setting of the governor, the governor closes and exhausts the air from beneath the unloader pistons. The unloader saddle spring forces the saddle, pistons and plungers down and the inlet valves return to their seats. Compression is then resumed.

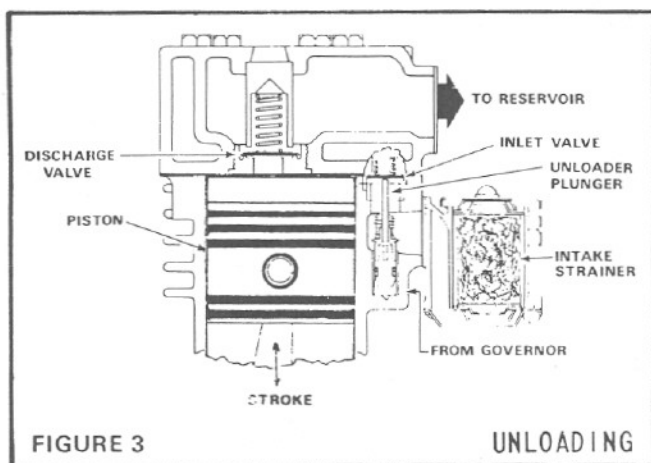

FIGURE 3

LUBRICATION

The vehicle's engine provides a continuous supply of oil to the compressor. Oil is routed from the engine to the compressor oil inlet. An oil passage in the compressor crankshaft allows oil to lubricate the connecting rod crankshaft bearings. Connecting rod wrist pin bushings and crankshaft ball bearings are splash lubricated. An oil return line connected from the compressor drain outlet to the vehicle engine crankcase allows for oil return.

COOLING

Air flowing through the engine compartment from the action of the engine's fan and the movement of the vehicle assists in cooling the crankcase. Coolant flowing from the engine's cooling system through connecting lines enters the compressor and flows through the internal passages in the cylinder block and head and is returned back to the engine. Proper cooling is important in maintaining discharge air temperatures below the maximum recommended 400°F.

PREVENTIVE MAINTENANCE

Depending upon the type air strainer and on the operating conditions and experience, service the air strainer as follows:

Sponge type: Clean or replace element every 5000 miles or 150 operating hours.

Paper Element: Replace every 20,000 miles or 800 operating hours

POLYURETHANE SPONGE STRAINER

Remove and wash all of the parts. The strainer element should be cleaned or replaced. If the element is cleaned, it should be washed in a commercial solvent or a detergent and water solution. The element should be saturated in clean engine oil, then squeezed dry before replacing it in the strainer. Be sure to replace the air strainer gasket if the entire air strainer is removed from the compressor intake.

DRY ELEMENT - PLEATED PAPER AIR STRAINER

Remove the spring clips from either side of mounting baffle and remove the cover. Replace the pleated paper filter and remount the cleaned cover, making sure the filter is in position. Be sure to replace the air strainer gasket if the entire air strainer is removed from the compressor intake.

NOTE: Some compressors are fitted with compressor intake adapters, which allow the compressor intake to be connected to the engine air cleaner. In this case, the compressor receives a supply of clean air from the engine air cleaner. When the engine air filter is changed, the compressor intake adapter should be checked. If it is loose, remove the intake adapter, clean the strainer plate, if applicable, and replace the intake adapter gasket, and re-install the adapter securely. Check line connections both at the compressor intake adapter and at the engine air cleaner. Inspect the connecting line for ruptures and replace it if necessary.

EVERY 6 MONTHS, 1800 OPERATING HOURS OR AFTER EACH 50,000 MILES

Remove the discharge fittings and inspect the compressor discharge port and discharge line for excessive carbon deposits. If excessive buildup is noted in either, the discharge line must be cleaned or replaced and the compressor checked more thoroughly. Carefully inspect the air induction system, oil supply and return system. If necessary, repair or replace the compressor. Depending upon type of

drive, check for proper belt and pulley alignment and belt tension. Adjust if necessary, paying special attention not to over-tighten the belt tension. Check for noisy compressor operation, which could indicate a worn drive gear coupling or a loose pulley. Adjust and/or replace as necessary. Check all compressor mounting bolts and retighten evenly if necessary. Check for leakage and proper unloader mechanism operation. Repair or replace parts as necessary.

EVERY 24 MONTHS, 7200 OPERATING HOURS OR AFTER EACH 200,000 MILES

Perform a thorough inspection, and depending upon the results of this inspection or experience, disassemble the compressor, clean and inspect all parts thoroughly, repair or replace all worn or damaged parts using only genuine Bendix replacements or replace the compressor with a genuine Bendix remanufactured unit.

IMPORTANT: Should it be necessary to drain the engine cooling system to prevent damage from freezing, the cylinder head of the compressor must also be drained.

GENERAL SERVICE CHECKS

INSPECTION

It is of the utmost importance that the compressor receives a clean supply of air. The air strainer must be properly

installed and kept clean. If the compressor intake is connected to the engine air cleaner, this connection must be properly installed and maintained. Check the compressor mountings to be sure they are secure. Check the drive for proper alignment, belt tension, etc.

Inspect the oil supply and return lines. Be sure these lines are properly installed and that the compressor is getting the proper supply of oil, and just as important, that the oil is returning to the engine. Check the coolant lines to and from the compressor. Check the unloader mechanism for proper operation.

OPERATING TESTS

Vehicles manufactured after the effective date of FMVSS 121, with the minimum required reservoir volume, must have a compressor capable of raising air system pressure from 85-100 psi in 25 seconds or less. This test is performed with the engine operating at maximum recommended governed speed. The vehicle manufacturer must certify this performance on new vehicles with appropriate allowances for air systems with greater than the minimum required reservoir volume.

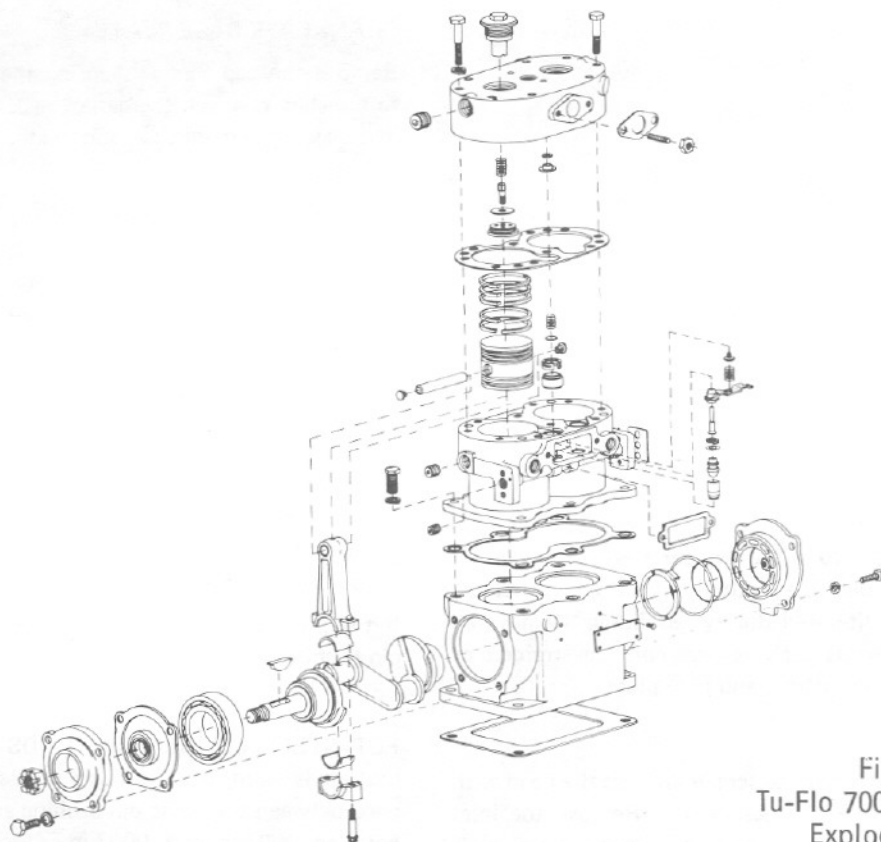

Fig. 4
Tu-Flo 700 Compressor
Exploded View

AIR LEAKAGE TESTS

Leakage past the discharge valves can be detected as follows: Remove the discharge line and cylinder head from the compressor and apply shop air back through the discharge port. Coat the discharge valve seats with soapsuds. Bubble leakage is permitted.

The unloader pistons can be checked for leakage as follows: Build up the air system to governor cut-out and shut off engine. Listen for escaping air at the compressor intake. To pinpoint leakage, apply a small amount of oil around the unloader pistons. No leakage permitted.

If the compressor does not function as described above, or leakage is excessive, it is recommended that it be returned to the nearest authorized Bendix distributor for a factory remanufactured compressor. If this is not possible, the compressor can be repaired using genuine Bendix replacement parts, in which case, the following information should prove helpful.

REMOVING AND DISASSEMBLY

REMOVING

These instructions are general and are intended to be a guide; in some cases additional preparations and precautions are necessary. Chock the wheels of the vehicle and drain the air pressure from all the reservoirs in the system. Disconnect all air, water, and oil lines leading to and from the compressor. Remove the drive gear(s) or pulley from the compressor crankshaft using a gear puller. Inspect the pulley or gear and associated parts for visible wear or damage. Since these parts are precision fitted, they must be replaced if they are worn or damaged.

DISASSEMBLY

GENERAL

Remove road dirt and grease from the exterior of the compressor with a cleaning solvent. Before the compressor is disassembled, the following items should be marked to show their relationship when the compressor is assembled. Mark both the front and rear end cover in relation to the crankcase. Mark the drive end of the crankshaft in relation to the front end cover and the crankcase. Mark the cylinder head in relation to the block and the block in relation to the crankcase. Mark the base plate or base adapter in relation to the crankcase.

A convenient method to indicate the above relationships is to use a metal scribe to mark the parts with numbers or lines. Do not use a marking method such as chalk that can be wiped off or obliterated during rebuilding. Remove all compressor attachments such as governors, air strainers or inlet fittings, discharge fittings and pipe plugs.

CYLINDER HEAD

Remove the cylinder head cap screws and tap the head with a soft mallet to break the gasket seal. Remove the inlet valve springs from the head and inlet valves from their

guides in the block. Scrape off any gasket material from the cylinder head and block. Unscrew the discharge valve seat from the head and remove the springs, guide and discharge valve. Inspect the discharge valve seats for nicks, cracks, and excessive wear, and replace if necessary. The discharge valve cap nut/stop should be removed and inspected for wear and replaced if excessive peening has occurred. To determine if excessive peening has occurred, measure the discharge valve travel. Discharge valve travel must not exceed .046 in. If discharge travel is excessive, replace cap nut/stop assembly, discharge valve and spring.

CYLINDER BLOCK

If compressor is fitted with an air strainer, inlet elbow or governor, remove same.

Remove cap screws securing cylinder block to crankcase; separate crankcase and cylinder block and scrape off gasket.

Remove unloader spring, spring saddle and spring seat from cylinder block.

Remove unloader guides and plungers and with the use of shop air blow unloader pistons out of cylinder block unloader piston bores.

Remove inlet valve guides; inlet valve seats can be removed but only if they are worn or damaged and are being replaced. Unloader bore bushings should be inspected but not removed unless they are damaged. If bushings are to be replaced, they can be removed by running a 1/8 in. pipe threaded rod and pulling the bushing straight up and out. Do not use an "easy-out" for removing the bushings.

CRANKCASE BASE PLATE

Remove the cap screws securing the base plate. Tap with soft mallet to break the gasket seal. Scrape off any gasket material from crankcase and plate.

CONNECTING ROD ASSEMBLIES

NOTE: Before removing the connecting rods, mark each connecting rod and its cap. Each connecting rod is matched to its own cap for proper bearing fit, and these parts must not be interchanged.

Remove the bolts and bearing caps. Push the piston with the connecting rods attached out the top of the cylinders of the block. Replace the bearing caps on their respective connecting rods. Remove the piston rings from the pistons. If the pistons are to be removed from the connecting rods, remove the teflon buttons and press the wrist pins from the pistons and connecting rods.

If the pistons are removed from the rod, inspect the wrist pin bushing.

FOR STEEL CONNECTING RODS ONLY — if wrist pin bushing is worn, press out and replace. Ream so that clearance between the wrist pin bushing and wrist pin should be between .0002 in. and .0007 in.

FOR ALUMINUM CONNECTING RODS ONLY – if wrist pin bushing is worn, discard rod assembly and replace with a new connecting rod assembly.

CRANKCASE

Remove the key or keys from the crankshaft and any burrs from the crankshaft where the key or keys were removed. (NOTE: Through drive compressors may have a crankshaft key at both ends.) Remove the end cover(s), taking care not to damage the crankshaft oil seal or front main bearing, if any. Remove end cover gasket(s) and oil seal(s). Replace oil seal after cleaning end cover(s). Press the crankshaft and bearings from crankcase, and press bearings from crankshaft.

CLEANING OF PARTS

GENERAL

All parts should be cleaned in a good commercial grade solvent and dried prior to inspection.

CYLINDER HEAD

Remove all the carbon deposits from the discharge cavities and all the rust and scale from the cooling cavities of the cylinder head body. Scrape all the foreign matter from the body surfaces and use shop air pressure to blow the dirt particles from all the cavities.

CYLINDER BLOCK

Clean the carbon and dirt from the inlet and unloader passages. Use shop air pressure to blow the carbon and dirt deposits from the unloader passages.

OIL PASSAGES

Thoroughly clean all oil passages through the crankshaft, crankcase, end covers, and base plate or base adapter. Inspect the passages with a wire to be sure they are clear. Blow the loosened foreign matter out with air pressure.

INSPECTION OF PARTS

CYLINDER HEAD BODY

Inspect the cylinder head for cracks or damage. Apply shop air pressure to one of the coolant ports with all others plugged, and check for leakage by applying a soap solution to the exterior of the body. If leakage is detected, replace the head.

END COVERS

Check for cracks and external damage. If the crankshaft main bearings (sleeve) are installed in the end cover, check for excessive wear and flat spots and replace them if necessary. If the compressor has an oil seal in the end cover, it should be removed by pressing it out of the end cover.

CRANKCASE

Check all crankcase surfaces for cracks and damage. On compressors where ball bearing main bearings are used, the

difference between the O.D. of the outer race and the I.D. of the crankcase hole should be .0000 in. to .0015 in. loose. This is to maintain the correct press fit. The crankcase must be replaced if the fit is too loose.

On compressors fitted with precision, sleeve main bearings, the difference between the O.D. of the crankshaft journal and the main bearing I.D. must not exceed .005 in. If the clearance is greater than .005 in., the end cover or main bearing must be replaced.

CYLINDER BLOCK

Check the unloader bore bushings to be sure they are not worn, rusted, or damaged. If these bushings are to be replaced, they can be removed by running a 1/8 in. pipe thread tap into the bushings, and inserting a 1/8 in. pipe threaded rod and pulling the bushing straight up and out. Do not use an "easy-out" for removing these bushings. If the inlet valve seats are worn or damaged, so they cannot be reclaimed by facing, they should be replaced. Cylinder bores which are scored or out of round by more than .001 in. should be rebored or honed oversize. Oversized pistons and piston rings are available in .010 in., .020 in. and .030 in. oversizes. Cylinder bores must be smooth, straight and round. Clearance between the cast iron pistons and cylinder bores should be between .002 in. minimum and .004 in. maximum.

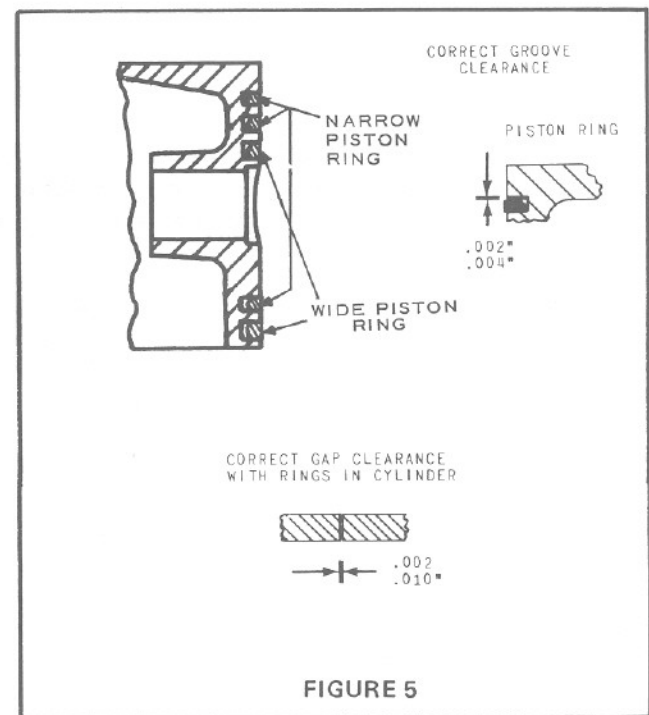

PISTONS

Check the pistons for scores, cracks, or enlarged ring grooves; replace the pistons if any of these conditions are found. Measure each piston with a micrometer in relation to the cylinder bore diameter to be sure the diametral clearance is between .002 in. minimum and .004 in. maximum.

Check the fit of the wrist pins to the pistons and connecting rod bushings. The wrist pin should be a light press fit in the piston. If the wrist pin is a loose fit, the piston and pin assembly should be replaced. Check the fit of the wrist pin in the connecting rod bushing by rocking the piston. This clearance should not exceed .0007 in.. If excessive clearance is found:

FOR STEEL CONNECTING RODS ONLY — press out wrist pin and replace. Ream so that clearance between wrist pin bushing and wrist pin should be between .0002 in. and .0007 in.

FOR ALUMINUM CONNECTING RODS ONLY — discard rod assembly and replace with a new connecting rod assembly.

Check the fit of the piston rings in the piston ring grooves. Check the ring gap with the rings installed in the cylinder bores. Refer to Fig. 5 for correct gap and groove clearance.

CRANKSHAFT

Check the crankshaft threads, keyways, ends and all machined and ground surfaces for wear, scores, or damage. Standard crankshaft journals are 1.1250 in.-1.1242 in. in diameter. If the crankshaft journals are excessively scored or worn, or out of round, the crankshaft must be replaced. Connecting rod bearing inserts are available in .010 in., .020 in., and .030 in. undersizes for compressors with reground crankshafts.

FOR BALL BEARINGS — main bearing journals must be maintained so ball bearings are a snug fit. If snug fit does not exist, the crankshaft should be replaced.

FOR SLEEVE BEARINGS — clearance between crankshaft journal must not exceed .005 in. If clearance is excessive, the sleeve bearing and crankshaft should be replaced with appropriate undersize parts.

If crankshafts are fitted with oil seal rings, the oil seal ring groove or grooves must not be worn. The ring groove walls must have a good finish and they must be square. Check to be sure the oil passages are open through the crankshaft.

CONNECTING ROD BEARINGS

Used bearing inserts must be replaced. Connecting rod caps are not interchangeable. The locking slots of the connecting rod and cap should be positioned adjacent to each other. Clearance between the connecting rod journal and the connecting rod bearing must not be less than .0003 in. or more than .0021 in. after rebuilding.

REPAIRS

DISCHARGE VALVES, VALVE STOPS AND SEATS

If the discharge valve seats merely show signs of slight wear, they can be dressed by using a lapping stone, grinding compound and grinding tool. Install the new discharge valve springs and valves. Screw in the discharge valve seats. Discharge valve travel should be between .030 in. to .046 in.

To test for leakage by the discharge valves, apply 100 psi to the cylinder head discharge port and apply a soap solution to the discharge valves and seats. Leakage in the form of soap bubbles is permissible. If excessive leakage is found, leave the air pressure applied and with the use of a fibre or hardwood dowel and a hammer, tap the discharge valves off their seats several times. This will help the valves to seat and should reduce the leakage. With the air pressure still applied at the discharge port of the cylinder head, check for leakage around the discharge valve cap nut on the top of the cylinder head casting. No leakage is permitted.

INLET VALVES AND SEATS

Inlet valves and springs should be replaced. If the inlet valve seats show signs of slight nicks or scratches, they can be redressed with a fine piece of emery cloth or by lapping with a lapping stone, grinding compound and grinding tool. If the seats are damaged to the extent that they cannot be reclaimed, they must be replaced. The dimension from the top of the cylinder block to the inlet valve should not exceed .113 in. nor be less than .101 in.

ASSEMBLY

GENERAL NOTE: All torques specified in this manual are assembly torques and typically can be expected to fall off after assembly is accomplished. **DO NOT RE-TORQUE** after initial assembly torques fall.

To convert inch pounds of torque to foot pounds of torque, divide inch pounds by 12.

$$\frac{\text{inch pounds}}{12} = \text{foot pounds}$$

To convert foot pounds of torque to inch pounds of torque, multiply foot pounds by 12.

$$\text{foot pounds} \times 12 = \text{inch pounds}$$

INSTALLING CRANKSHAFT

If the crankshaft is fitted with oil seal rings, install rings. Position ball bearing(s) and crankshaft in crankcase, making certain the drive end of the crankshaft is positioned in the crankcase as marked before disassembly.

If one end of the crankcase is counterbored for a ball bearing, make certain the crankshaft is installed through the correct end of the crankcase. Carefully press the crankshaft and bearings into the crankcase.

Position a new rear end cover gasket over the rear end of the crankcase, making certain the oil hole in the gasket lines up with the oil hole in the crankcase. Install end cover with oil seal ring (if used) on crankcase. The end cover should be positioned correctly in relation to the oil holes in the gasket and crankcase. Install cap screws with lock washers and torque to 175-225 inch pounds.

If the opposite end cover requires an oil seal, the new seal should be pressed into the end cover. Install a new end cover gasket and carefully install end cover over crankshaft and to crankcase to avoid damage to seal. Install cap screws and lock washers and torque to 175-225 inch pounds.

PISTONS AND CONNECTING RODS

If new wrist pin bushings are to be used (steel rods only) they should be pressed into the connecting rods so that the oil hole in the bushing lines up with the one in the rod. The new bushings should then be reamed or honed to provide between .0002 in. and .0007 in. clearance on the wrist pin. Position the connecting rod in the piston and install a teflon button on each side of the piston. Install the piston rings in the correct location with the ring pip-marks up. Stagger the position of the ring gaps. Prelubricate the piston, piston rings, wrist pin, and connecting rod bearings with clean engine oil before installing them in the compressor. Remove the connecting bolts and bearing and bearing cap from one connecting rod. Turn the crankshaft so that one of its connecting rod journals is in the downward, center position. Install the crankshaft journal bearing segments in the connecting rod and connect the rod cap. Insert the connecting rod with piston through the top of the cylinder. Position and attach the bearing cap to the connecting rod. Tighten the connecting rod bolts evenly and torque to 125-140 inch pounds. Install the other connecting rod and piston in the same manner. It is recommended that new connecting rod cap screws be used.

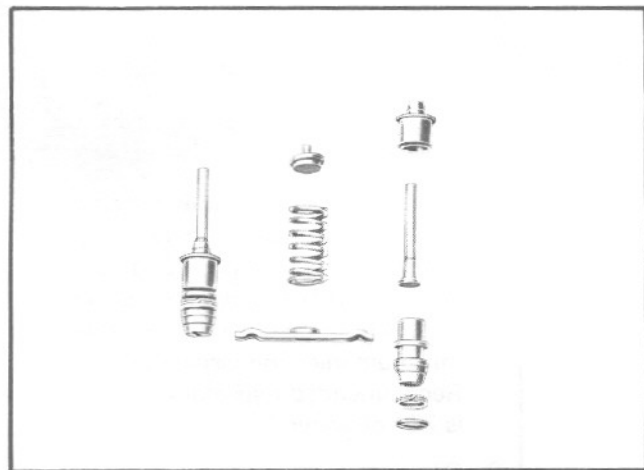

FIGURE 6

UNLOADER

A new unloader kit should be used when rebuilding (piece number 279615). The unloader pistons in the kit are pre-lubricated with a special lubricant (piece number 239379) and do not require additional lubrication. Install the unloader pistons in their bores, being careful not to cut the O-Rings or distort the back-up rings. Position the unloader plungers in their guides and slip them in and over the tops of the pistons. Install the unloader spring seat in the cylinder block inlet cavity; a small hole is drilled in the block for this purpose. Position the saddle between the unloader piston guides, so its forks are centered on the guides. Install the unloader spring, making sure it seats over the spring seats both in the block and on the saddle. Position and install the inlet valve guides, then drop the inlet valves in their guides. There should be a loose sliding fit between the guides and valves.

CYLINDER HEAD

Install the inlet valve springs in the cylinder head by applying a turning motion to the spring after it is in the head. The turning motion should dig the spring wire into the spring seat in the bottom of the spring bore in the head. Should this procedure fail after repeated attempts, use a very small quantity of grease to hold them in place (just enough to keep the springs from falling out). Place the cylinder head gasket on the cylinder block. Carefully align the cylinder head assembly on the block and install the cap screws, tightening them evenly to a torque of 175-225 inch pounds.

BASE PLATE

Position the base plate gasket on the crankcase and install the base plate or base adapter as marked before disassembly. Tighten cap screws securing the base plate to a torque of:

- 1/4 - 20 hex hd. - 85 to 115 inch pounds
- 5/16 - 18 hex hd - 95 to 125 inch pounds

TESTING REBUILT COMPRESSOR

In order to properly test a compressor under operating conditions, a test rack for correct mounting, cooling, lubricating, and driving the compressor is necessary. Such tests are not compulsory if the unit has been carefully rebuilt by an experienced person. A compressor efficiency or build-up test can be run as follows: An engine lubricated compressor must be connected to an oil supply line of at least 15 pounds pressure during the test and an oil return line must be installed to keep the crankcase drained.

Connect to the compressor discharge port, a reservoir with a volume of 1500 cubic inches, including the volume of connecting line. With the compressor operating at 2100 rpm, the time required to raise the reservoir pressure from 85 psi to 100 psi should not exceed 5 seconds. During this test, the compressor should be checked for gasket leakage and noisy operation, as well as unloader operation and leakage.

INSPECTION OF REBUILT UNIT

Check to be sure that covers, plugs, or masking tape are used to protect all ports if compressor is not to be installed immediately. Fit the end of all crankshafts with keys, nuts, and cotter pins as required and then protect the ends against damage by wrapping with masking tape or friction tape. The open bottom of a vertical engine lubricated compressor should be protected against the entrance of dirt during handling or storage, by installing a temporary cover over the base.

TU-FLO 700 COMPRESSOR

SPECIFICATIONS

Number of cylinders	2
Bore size	2.75"
Stroke	1.81"
Displacement @ 1250 RPM	15.5 CU. FT.
Maximum recommended RPM	3000
Minimum coolant flow at maximum RPM	2.5 GAL/MIN.
Recommended maximum inlet temp.	250° F
Recommended maximum discharge temp.	400° F
Minimum pressure required to unload	60 PSI
Recommended air induction	naturally aspirated only
Weight	46 lbs. (approx.)

RECOMMENDED CONNECTING LINE SIZES

Discharge line	5/8" O.D. Min. copper tube
Inlet line (when connected to engine air cleaner)	5/8" I.D. Min.
Oil supply line	1/4" O.D. tubing
Oil return line	5/8" O.D. tubing
Unloader line	1/4" O.D. tubing
Coolant lines	1/2" O.D. tubing

IMPORTANT! PLEASE READ

When working on or around air brake systems and components, the following precautions should be observed:

1. Always block vehicle wheels. Stop engine when working under a vehicle. Depleting vehicle air system pressure may cause vehicle to roll. Keep hands away from chamber push rods and slack adjusters; they may apply as system pressure drops.
2. Never connect or disconnect a hose or line containing air pressure. It may whip as air escapes. Never remove a component or pipe plug unless you are certain all system pressure has been depleted.
3. Never exceed recommended air pressure and always wear safety glasses when working with air pressure. Never look into air jets or direct them at anyone.
4. Never attempt to disassemble a component until you have read and understand recommended procedures. Some components contain powerful springs and injury can result if not properly disassembled. Use only proper tools and observe all precautions pertaining to use of those tools.

COMPRESSOR TROUBLESHOOTING CHART

SYMPTOMS	CAUSE	REMEDY
1. Compressor passes excessive oil as evidenced by presence of oil at exhaust ports of valving or seeping from air strainer.	A. Restricted air intake.	A. Check engine or compressor air cleaner and replace if necessary. Check compressor air inlet line for kinks, excessive bends and be certain inlet lines have the minimum specified inside diameter. Recommended minimum inlet line inside diameter is 5/8". Recommended maximum air inlet restriction is 25" of water.
	B. Restricted oil return (to engine).	B. Oil return to the engine should not be in any way restricted. Check for excessive bends, kinks, and restrictions in the oil return line. Minimum recommended oil return line size is 5/8" O.D. tubing or equivalent I.D. (1/2" minimum). Return line must CONSTANTLY DESCEND from the compressor to the engine crankcase. Make certain oil drain passages in the compressor and mating engine surfaces are unobstructed and aligned. Special care must be taken when sealants are used with, or instead of, gaskets.
	C. Poorly filtered inlet air.	C. Check for damaged, defective or dirty air filter on engine or compressor. Check for leaking, damaged or defective compressor air intake components (i.e., induction line, fittings, gaskets, filter bodies, etc). The compressor intake should not be connected to any part of the exhaust gas recirculation (E.G.R.) system on the engine.

SYMPTOMS

CAUSE

REMEDY

D. Insufficient compressor cooling (compressor runs hot).

D. For air-cooled compressor or air-cooled portions of the compressor:

1. Remove accumulated grease, grime, or dirt from the cooling fins. Replace components found damaged.
2. Check for damaged cooling fins. Replace components found damaged.
3. Air-cooled compressors should not be used on engines equipped with fan clutches.

For water-cooled compressor or water-cooled portions of the compressor:

1. Check for proper coolant line sizes. Minimum recommended size is 1/2" O.D. tubing.
2. Check the coolant flow through the compressor. Minimum allowable flow is 2.5 gallons per minute at engine governed speed. If low coolant flow is detected, inspect the coolant lines and fittings for accumulated rust scale, kinks and restrictions.
3. Water temperature should not exceed 200° F.
4. Optimum cooling is achieved when engine coolant flows into the compressor cylinder block at one end and out the compressor cylinder head at the opposite end.

E. Contaminants not being regularly drained from system reservoirs.

E. Check reservoir drain valves to insure that they are functioning properly. It is recommended that the vehicle should be equipped with functioning automatic drain valves, or have all reservoirs drained to zero (0) psi daily, or optimally to be equipped with a desiccant-type air dryer prior to the reservoir system.

F. Compressor runs loaded an excessive amount of time.

F. Vehicle system leakage should not exceed industry standards of 1 psi pressure drop per minute without brakes applied, and 3 psi pressure drop per minute with brakes applied. If leakage is excessive, check for system leaks and repair.

G. Excessive engine crankcase pressure.

G. Test for excessive engine crankcase pressure and replace or repair crankcase ventilation components as necessary. (An indication of crankcase pressure is a loose or partially lifted dipstick.)

H. Excessive engine oil pressure.

H. Check the engine oil pressure with a test gauge and compare the reading to the engine specifications. Bendix does not recommend restricting the compressor oil supply line because of the possibility of plugging the restriction with oil contaminants. Minimum oil supply line size is 1/4" O.D. tubing.

SYMPTOMS

CAUSE

REMEDY

2. Noisy compressor operations.	I. Faulty compressor. A. Loose drive gear or pulley.	I. Replace or repair the compressor only after making certain none of the preceding installation defects exist.
	B. Excessively worn drive couplings or gears. C. Compressor cylinder head or discharge line restrictions. D. Worn or burned out bearings. E. Faulty compressor.	A. Inspect the fit of the drive gear on pulley o the compressor crankshaft. The pulley on gear must be completely seated and the crankshaft nut must be tight. If the compressor crankshaft surface or its keyway are damaged, it is an indication of loose drive components. If damage to the compressor crankshaft is detected, replace the compressor or the crankshaft. When installing the drive gear or pulley, torque the crankshaft nut to 100 foot pounds. DO NOT BACK OFF THE CRANKSHAFT NUT TO ALIGN THE COTTER PIN AND CASTELLATED NUT. (Some compressors do not use castellated nuts.) DO NOT USE IMPACT WRENCHES. B. Inspect drive gear and couplings and engine for excessive wear. Replace as necessary. (Non-metallic gears should be replaced when the compressor is changed.) 501 drive gear should be metal-type on Detroit Diesel engine. C. Inspect the compressor discharge port and discharge line for carbon build-up. If carbon is detected, check for proper cooling to the compressor. (See Cause and Remedy (D) under Symptom #1.) Inspect the discharge line for kinks and restrictions. Replace discharge line as necessary. D. Check for proper oil pressure in the compressor. Minimum required oil pressure; 5 psi engine idling, 15 psi maximum governed engine rpm. Check for excessive oil temperature—should not exceed 240° F. E. Replace or repair the compressor after determining none of the preceding installation defects exist.
3. Excessive build-up and recovery time. Compressor should be capable of building air system from 85-100 psi in 40 seconds with engine at full governed rpm. Minimum compressor performance is certified to meet Federal requirements by the vehicle manufacturer. Do not downsize the original equipment compressor.	A. Dirty induction air filter. B. Restricted induction line. C. Restricted discharge line or compressor discharge cavity.	A. Inspect engine or compressor air filter and replace if necessary. B. Inspect the compressor air induction line for kinks and restrictions and replace as necessary. C. Inspect the compressor discharge port and line for restrictions and carbon build-up. If a carbon build-up is found, check for proper compressor cooling. Replace faulty sections of the discharge line.

SYMPTOMS

CAUSE

REMEDY

	<p>D. Slipping drive components.</p> <p>E. Excessive air system leakage.</p>	<p>D. Check for faulty drive gears and couplings and replace as necessary. Check the condition of drive belts and replace or tighten, whichever is appropriate.</p> <p>E. Test for excessive system leakage and repair as necessary. Use the following as a guide: Build system pressure to governor cutout and allow the pressure to stabilize for one minute. Using the dash gauge, note the system pressure and the pressure drop after two minutes.</p> <p>The pressure drop for Pre-1975 vehicles should not exceed:</p> <ol style="list-style-type: none"> 1. 4 psi for a single vehicle. 2. 6 psi for a tractor trailer. 3. 10 psi for a tractor and 2 trailers. <p>The pressure drop for Post-1975 vehicles should not exceed:</p> <ol style="list-style-type: none"> 1. 2 psi in each reservoir for a single vehicle. 2. 6 psi in each reservoir for a tractor and trailer. 3. 8 psi in each reservoir for a tractor and 2 trailers.
	<p>F. Sticking unloader pistons and plungers.</p>	<p>F. Check the operation of the unloading pistons in the inlet cavity of the compressor. Both pistons should have the plunger flanges resting on the inlet cavity floor when the compressor is loaded (pumping air). If the pistons and plunger are not fully retracted, check for proper operation of the compressor air governor. If the governor is operating properly, replace the unloader pistons and plungers and inspect their bores in the cylinder block. Clean lubricate as necessary. Inspect for bent, kinked or blocked tubing leading to or from the governor.</p>
<p>4. Compressor fails to unload.</p>	<p>G. Faulty compressor.</p> <p>A. Faulty governor or governor installation.</p> <p>B. Faulty or worn unloader pistons or bores.</p>	<p>G. Replace or repair the compressor after determining none of the preceding installation defects exist.</p> <p>A. Test the governor for proper operation and inspect air lines to and from the governor for kinks or restrictions. Replace or repair the governor or its connecting air lines.</p> <p>B. Inspect for worn, dirty or corroded unloader pistons and their cylinder block bores. Replace as necessary.</p>
<p>5. Compressor leaks oil.</p>	<p>A. Damaged mounting gasket.</p>	<p>A. Check the compressor mounting bolt torque. If the mounting bolt torque is low, replace the compressor mounting gasket before retorquing the mounting bolts.</p>

SYMPTOMS

CAUSE

REMEDY

	<ul style="list-style-type: none"> B. Cracked crankcase, cylinder block or end cover. C. Loose end cover or cylinder block cap screws. D. Loose oil supply or return line fittings. E. Porous compressor casting. F. Mounting flange or end cover, O-Ring or gasket—missing, cut, or damaged. 	<ul style="list-style-type: none"> B. Visually inspect the compressor exterior for cracked or broken components. Cracked or broken crankcases or mounting flanges can be caused by loose mounting bolts. The end cover can be cracked by over-torquing fitting or plugs installed in the end cover. Replace or repair the compressor as necessary. C. Check the cap screw torques and tighten as necessary. D. Check the torque of external oil line fittings and tighten as necessary. E. Replace the compressor if porosity is found. F. Replace as necessary.
<p>6. Compressor constantly cycles (compressor remains unloaded for a very short time.)</p>	<ul style="list-style-type: none"> A. Leaking compressor unloader pistons. B. Faulty governor. C. Excessive system leakage. D. Excessive reservoir contaminants. 	<ul style="list-style-type: none"> A. Remove the compressor inlet air strainer or fitting. With the compressor unloaded (not compressing air), check for air leakage around the unloader pistons. Replace as necessary. B. Test the governor for proper operation and repair or replace as necessary. C. Test for excessive system leakage as instructed in Symptom 3, Remedy E. Reduce leakage wherever possible. D. Drain reservoirs.
<p>7. Compressor leaks coolant.</p>	<ul style="list-style-type: none"> A. Improperly installed plugs and coolant line fittings. B. Freeze cracks due to improper anti-freeze strength. C. Faulty compressor (porous castings). 	<ul style="list-style-type: none"> A. Check torque of fittings and plugs and tighten as necessary. Over-torque fittings and plugs can crack the head or block casting. B. Test anti-freeze and strengthen as necessary. Check coolant flow through compressor to assure the proper anti-freeze mixture reaches the compressor. C. If casting porosity is detected, replace the compressor.
<p>8. Compressor head gasket failure.</p>	<ul style="list-style-type: none"> A. Restricted discharge line. B. Loose head bolts. C. Faulty compressor or head gasket. 	<ul style="list-style-type: none"> A. Clear restriction or replace line. B. Tighten evenly to a torque of 25-30 foot pounds. C. Check for rough or poorly machined head or block surfaces. Replace necessary components.