

DAVID LEVY COMPANY, INC.

\$5.00

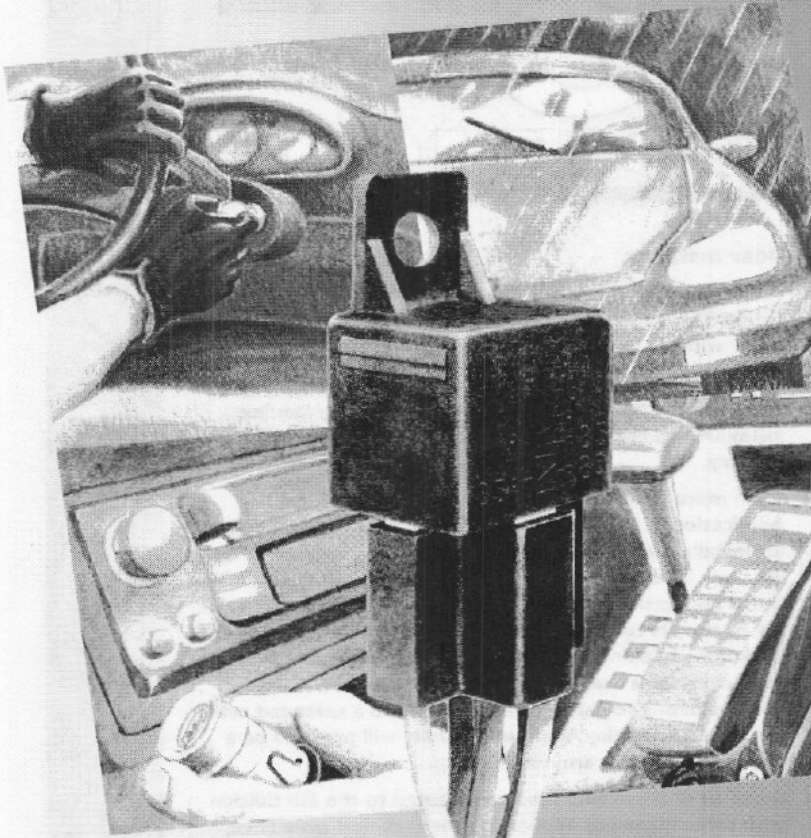

RELAY
APPLICATIONS

GUIDE

6TH EDITION

DLC

RELIABLE

OP4 relay

6th EDITION

Dear Installer,

We are excited about our 6th Edition Relay Application Guide! This book is offered FREE any time you place an order with us.

The Guide has been revised and expanded to 44 pages of valuable tech tips featuring circuits designed by leading installers and installation support teams from around the country.

With more than 40,000 copies in print, DLC's Relay Application Guide has become an important reference tool for installers everywhere. Many positive changes in our latest book include a reorganized layout by subject and additional applications for specific vehicles. With a greater variety of circuits to choose from and an easier format to use, we know you'll find time-saving tips and solutions to those little challenges that pop up from time to time. Whether you're starting to get your feet wet or are a seasoned veteran, the DLC Relay Application Guide will prove to be a handy tool to have around the shop.

So, to all of those who have contributed to the 6th Edition with some ingenious applications or technical assistance, **our thanks and recognition.**

Enjoy,

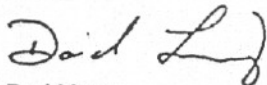

David Levy

P.S. By the way, if you have a relay application for our next edition, send it to us, we'd like to have it from you.



DAVID LEVY
COMPANY, INC.

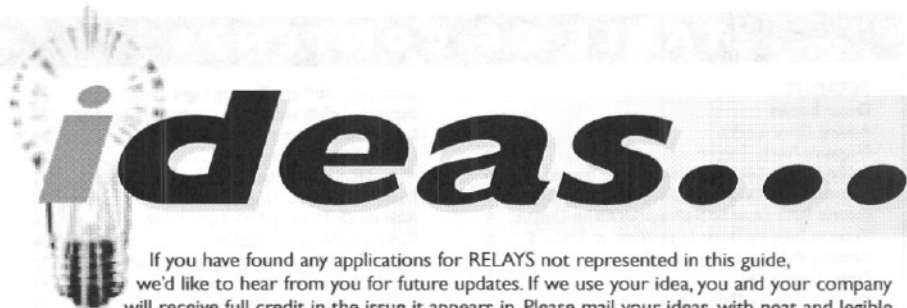

ideas...

If you have found any applications for RELAYS not represented in this guide, we'd like to hear from you for future updates. If we use your idea, you and your company will receive full credit in the issue it appears in. Please mail your ideas, with neat and legible schematics (with your name, company, address and phone number clearly marked on each page) to:

DAVID LEVY COMPANY, INC.

12753 MOORE STREET • CERRITOS, CA 90703 • ATTN: RELAY GUIDE

THANK YOU!

WE WOULD LIKE TO THANK THE FOLLOWING PEOPLE AND ORGANIZATIONS FOR THEIR VALUABLE CONTRIBUTION WITH IDEAS AND TECHNICAL SUPPORT. SEND IN MORE!

ERIC ABBISS

SHERWOOD SECURITY
LA MIRADA, CALIFORNIA

LEO ALVA

EL MONTE, CALIFORNIA

KIRK ATAMIAN

CAPTAIN KIRK'S SOUND SYSTEMS
MADERA, CALIFORNIA

SKIP ATKINS

CELLULAR U.S.A., INC.
SANTA ANA, CALIFORNIA

RON BASOFF

B&B ELECTRONICS
VAN NUYS, CALIFORNIA

STUART H. BENTON

STAR ALARM CUSTOM
AUTO SECURITY
CAMARILLO, CALIFORNIA

DWIGHT BROWN

D.B. & SONS MOBILE ELECTRONICS
CHICAGO, ILLINOIS

CRAIG CHAMPAGNE

JODI'S SOUND, INC.
MANCHESTER, CONNECTICUT

VICTOR CHIN

SECO-ALARM U.S.A., INC.
IRVINE, CALIFORNIA

PETER CONSOLO

PETCO SECURITY SYSTEMS
BROOKLYN, NEW YORK

KEN CORRENTI

PROFESSIONAL PRODUCTS
& SERVICES
ST. LOUIS, MISSOURI

DENNIS DECK

VSE SECURITY
CHATSWORTH, CALIFORNIA

JASON DZABO

SECURITY ALARM SYSTEMS
KNOXVILLE, TENNESSEE

MARTIN ENCINAS

PROGUARD
TEMPE, ARIZONA

PAUL FISCARELLI

THE AUDIO-MOBILE SHOP
LATHAM, NEW YORK

TONY GAROWSKI

H.G. BRIX COMPANY
SACRAMENTO, CALIFORNIA

CHRIS GENDUSO

THE HI FI SHOP
FALLBROOK, CALIFORNIA

JERRY GILBER

PRO-TEK ALARMS
LONG BEACH, CALIFORNIA

STEVE GROSS

KATONAH, NEW YORK

JOHN GUNDLACH

PACIFIC ELECTRONICS
STOCKTON, CALIFORNIA

ERIC HIMSCHOOT

AUTO SECURITY
FT. LAUDERDALE, FLORIDA

GARY HOFFMAN

HOFFCO ALARMS
CULVER CITY, CALIFORNIA

GEORGE KENTON

PRO SOUND CAR STEREO
AUBURN, CALIFORNIA

INSTALLATION NEWS

REDONDO BEACH, CALIFORNIA

JASON KITCHING

MICKEY SHORR
LEONARD, MICHIGAN

SHI HOON LEE

CHANG'S #1 AUTO
SERVICE CENTER
LOS ANGELES, CALIFORNIA

MATT LIVELY

DYER ELECTRONICS
VICTORIA, TEXAS

MARK LYNCH

ML AUDIO
ROSEVILLE, CALIFORNIA

JASON LUDWIG

CUSTOM PERFORMANCE & DETAIL
BURBANK, CALIFORNIA

JOHN MARTIN

CAR SOUND CO.
LONG BEACH, CALIFORNIA

J.T. MORELAN

AUTOSHADOWS & SECURITY OF TEXAS
GARLAND, TEXAS

BILL MURAKAMI

CRAZY STEREO
HARBOR CITY, CALIFORNIA

GUS MURILLO

STARTRONICS
SANTA MONICA, CALIFORNIA

GINO MUSOLINO

TECHNE ELECTRONICS LTD.
PALO ALTO, CALIFORNIA

DAVID NAVONE

NAVONE ELECTRONICS
STOCKTON, CALIFORNIA

KAHN Q. NGUYEN

HURLEY'S AUTO RADIO
MCLEAN, VIRGINIA

ENRIQUE ORTIZ

AUTO SOUND & SECURITY
LOS ANGELES, CALIFORNIA

HAROLD OTTO

OTTOTRONICS INC.
YONKERS, NEW YORK

MONTICE PAUL

STEREO HOUSE
PASADENA, CALIFORNIA

DAVE PIROLI

THE AUDIO-MOBILE SHOP
LATHAM, NEW YORK

SPENCER QUEVEDO

KUSTOM SOUNDS
MAYWOOD, CALIFORNIA

BILL RUSSELL

RAYCO CAR ELECTRONICS
SHREWSBURY, MASSACHUSETTS

KIT SAMSON

AUTOACCESS
LOS ANGELES, CALIFORNIA

RANDY SANDERS

VEHICLE SECURITY
ELECTRONICS
CHATSWORTH, CALIFORNIA

JOHN STUDLEY

AVITAL TECHNOLOGIES
BUFFALO GROVE, ILLINOIS

RICHARD TATAZIAN

VISIONS OF VIDEO
NORTHRIDGE, CALIFORNIA

MARK A. TORTOMASI

CIRCUIT CITY
HOOVER, ALABAMA

KIRK TRACHY

SOUND ADVICE
STRATHAM, NEW HAMPSHIRE

DAVE WILKINSON

WILKINSON AUTO &
HOME SECURITY
IRVINE, CALIFORNIA

MIKE WUTTKE

AUTORADIO STEREO
CITRUS HEIGHTS, CALIFORNIA

TABLE OF CONTENTS

SECURITY

Door Locks

Adding Door Locks-	
Negative Alarm Trigger	4
Adding Door Locks- Positive Alarm Trigger	4
Negative Pulse Door Locks/Negative Alarm Output	5
Positive Pulse Door Locks/Negative Alarm Output	5
Reverse Polarity Door Locks/Rest at Ground	6
Reverse Polarity Door Locks/Rest	
Open Circuit (A)	6
Reverse Polarity Door Locks/Rest	
Open Circuit (B)	7
Interface W/Dual Voltage Systems- 1994 Probe	7
Door Lock Systems using Vacuum Pump	8
Passenger Door Unlock Bypass Circuit/Universal	8
Selective Door Unlock/Negative Pulse System	9
Selective Door Unlock/Positive Pulse System	9
Selective Door Unlock/Reverse Polarity System	10
Specialty Door Locks/93 Chrysler LeBaron/ Dodge Daytona	10
Specialty Door Locks/(-) Pulse/Interrupt	
Door Locks- Nissan	11
Specialty Door Locks/1994 Range Rover	11
Specialty Door Locks/85-86 Toyota Van	12
Specialty Door Locks/Door Locks-Volvo	12

Starter Disable

Starter Kill via Hidden Toggle Switch	13
Hidden Toggle Starter Disable/Extra Security	13
Ignition Kill Circuit	14
Safety Starter Cut-off	14
Stealth Starter Interrupt	15
Starter Disable/Cigarette Lighter Inoperative	15
Starter Disable/Cigarette Lighter Operative	16
Keyless Entry w/Cigarette Lighter/Extra Security	16

Miscellaneous

Alarm Trigger Inverter	17
Adding a Pager to an existing Alarm	17
Alarm Pager Antenna Driver	18
Factory Horn Honk with Silent Alarm	18
Fake Alarm Flashing LED	19
Ignition Sensing LED	19
Simple Auto Alarm	20
Cheap, Dependable Car Alarm	20
Alarm for Motorcycles	21

LIGHTING CIRCUITS

Parking Light Flashing Circuits	21
Two Way Flasher	22
Flasher Circuit for European Cars	22

Separate Left/Right Parking Light Circuits (A)	23
Separate Left/Right Parking Light Circuits (A)	23
Left to Right Flashing High Beams	24
Left to Right Flashing Lights	24
Horn Honk/Light Flash Circuit	25
Flasher/Honker Circuit	25
Alternately Flashing Park Light/Horn	26
Parking Light Safety Flasher	26
Wiper Turn-On Parking Lights & Headlights	27
Wipers/Lights Turn-On Together	27
Courtesy/Car Identifier Lights	28
Audible "Chirp" to Visual "Blink" Conversion	28
Flasher LED to Light Converter	29
Basic Fog Light Systems	29
Auxiliary Fog Light Control	30

AUTOSOUND & CELLULAR

Ignition Bypass to Eliminate Noise	30
Amp System Remote Power Switch	31
Switching Module	31
Accessory Power Back-up Circuit	32
Automatic Antenna Switching Relay	32
Auto Antenna Protector	33
Stereo Disable with Cigarette Lighter	33
Horn Alert for Cellular Phones	34
Horn Alert with Buzzer	34

LATCHING TYPES

Simple Latch(-) Turn-On, (+) Turn-Off/(-) Output	35
Simple Latch(-) Turn-On, (-) Turn-Off/(+) Output	35
Simple Latch(+) Turn-On, Remove (-) Turn-Off, (+) Output	36
Optional Methods of Latching Relays (1)	36
Optional Methods of Latching Relays (2)	37
Latching Trigger Alarm	37

MISCELLANEOUS

Transfer Function of a Relay	38
Third Function Auxiliary Channel	38
Dual Feature auxiliary Switch	39
Channel Splitter (Armed/Disarmed)	39
Pulse-On/Pulse-Off Relay	40
Steering Wheel Tilt using a Remote Starter	40
The "Poor Person's" Keyless Entry	41
Power Trunk Release with Positive Pulse	41
Trunk Release for 1994 Cadillac Sedan De Ville	42

GENERAL & PRODUCT INFORMATION

Electronic Symbols	3
MECP Study Guide	42
About Relays	3
Catalog Request Form	43

IMPORTANT INFORMATION!

This guide book is only a **GUIDE**. The applications shown are general guidelines of the possible uses for SPDT relays and may vary slightly from car to car, depending on model, make or other variables.

ALWAYS CONSULT THE CAR'S SERVICE MANUAL WHEN ATTEMPTING AN INSTALLATION.

David Levy Co., Inc. does not assume any responsibility for damage to person or property which may occur due to incorrect applications, or misinterpretation of the applications appearing in this guide. Not responsible for typographical or printing errors.

ALL RELAYS PICTURED IN THE DIAGRAMS ARE 12V 20/30 AMP SPDT RELAYS
UNLESS OTHERWISE STATED.

ABOUT BOSCH RELAYS

A **relay** is an "electromechanical" device that uses a coil (electro) to move switch contacts (mechanical). The coil can be energized with a small amount of power while the switch contacts can be used for any number of applications including switching high power circuits or reversing the polarity of a control signal. A typical 12-volt relay requires a coil current of .150 amps to energize. The relay contacts can switch currents up to 30 amps. The power "gain" of this relay is as high as 200 to 1, and is one reason relays are often found in high current automotive circuits. In most circuits, a relatively weak signal or trigger is used to make the relay control a higher current or voltage circuit. The output of a trigger actuates the coil, which closes (or opens) the much heavier duty contacts, allowing the desired action to result. The main components of a relay are the **coil**, the **spring**, and the **contacts**. These components determine how the relay is to be rated by the manufacturer and used by the installer. Below is an illustration of the bottom of a relay.

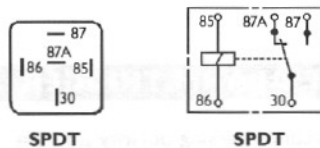

Element descriptions to the above two diagrams follow:
85, 86 - Coil. This is what is powered, either by a 12-volt trigger to 85 (or 86) with 86 (or 85) to ground, or with a negative trigger (com-

mon on alarm systems) to 85 (or 86), and 12-volt CONSTANT to the other pin (86 or 85). Basically, it doesn't matter whether pin 85 or 86 is used for ground or 12 volt if the relay does not have a diode across the coil. Bosch states that 86 should be the 12V connection and 85 should be the ground since newer relays come with an internal diode. By using either of the previous methods, the coil will magnetically actuate, opening contacts 30 and 87A, while closing 30 and 87. This type of relay is known as a single pole, double throw (SPDT).

30 - Terminal 30 is common. One side of whatever is being controlled goes here.

30, 87A - Normally closed (N/C).

30, 87 - Normally open (N/O).

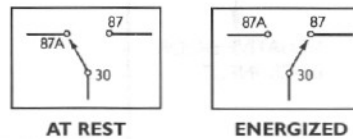

The following diagrams show the other types of commonly used automotive relays:

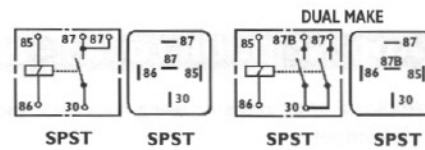

Whenever installing a relay, use a quenching diode between terminals 85 and 86, with a cathode to the positive terminal to prevent the inductive spike on relay turn-off.

ELECTRONIC SYMBOLS

FUSE OR

GROUND

BATTERY

CAPACITOR OR
 FIXED POLARIZED OR FIXED NON-POLARIZED
 RESET BUTTON

CIRCUIT BREAKER

DIODE
 GENERAL LIGHT EMITTING ZENER

INDUCTOR AIR CORE IRON CORE

WIRES CONNECTED CROSSED

POTENTIOMETER (ATTENUATOR) OR

RESISTOR

SIGNAL GENERATOR

SPEAKER

TRANSLATOR
 NPN PNP DARLINGTON TYPE

ADDING DOOR LOCKS – NEGATIVE ALARM TRIGGER

Negative door lock and unlock output reversing polarity.

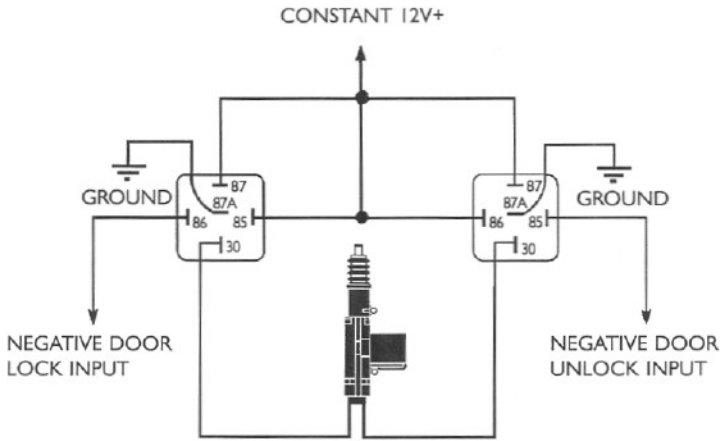

ADDING DOOR LOCKS – POSITIVE ALARM TRIGGER

Adding a door actuator using door lock and unlock circuit, reversing polarity positive 12V output.

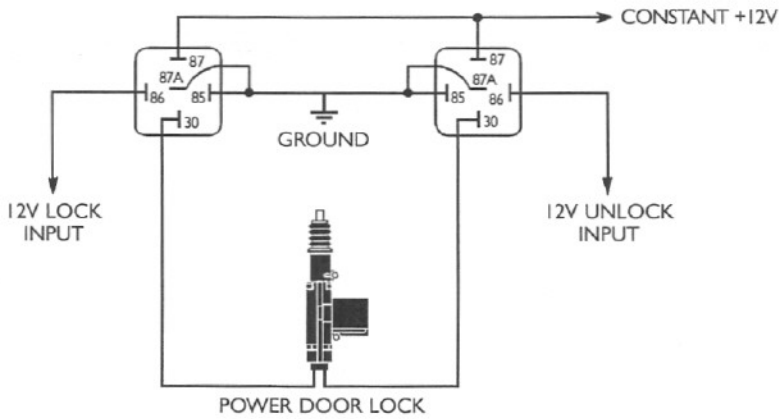

NEGATIVE-PULSE DOOR LOCKS/NEGATIVE ALARM OUTPUT

This wiring diagram is for cars with factory lock relays.

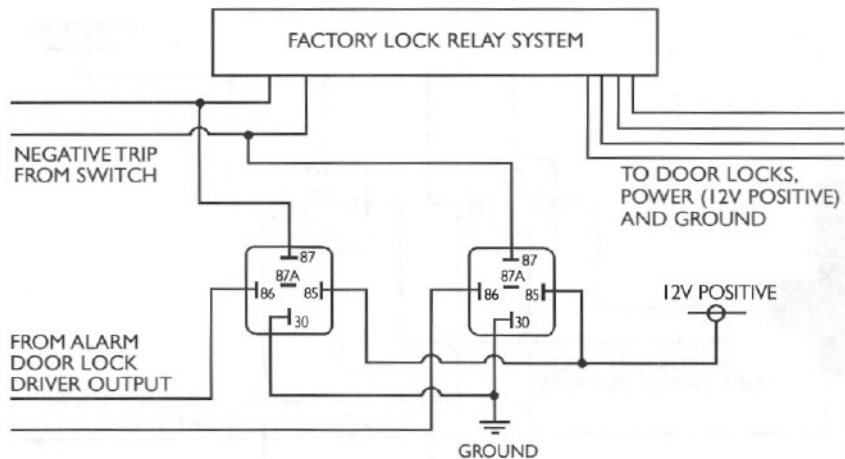

POSITIVE-PULSE DOOR LOCKS/NEGATIVE ALARM OUTPUT

This wiring diagram is for cars with factory lock relays.

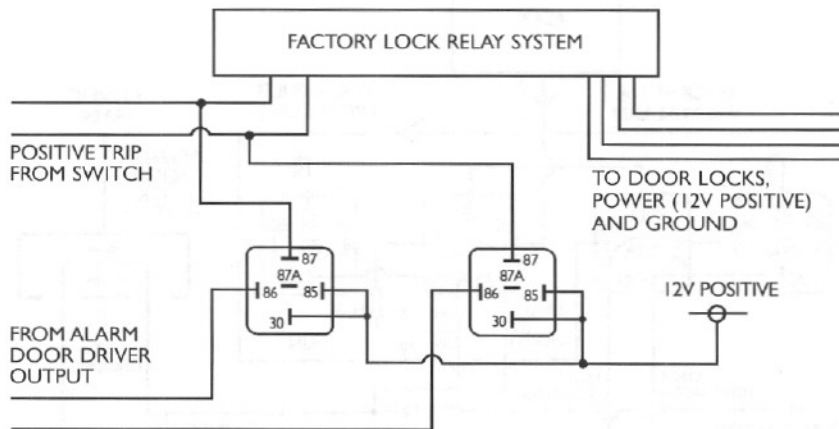

REVERSE POLARITY DOOR LOCKS/REST AT GROUND

Wires for factory reversing polarity locks will show constant ground (-) when not in use. When cutting the factory wires, the wires retaining the constant ground are the switch (or relay) outputs.

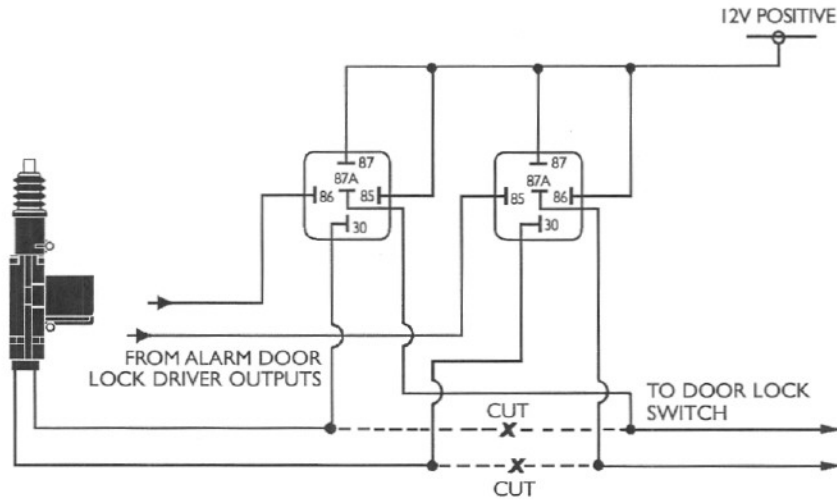

REVERSE POLARITY DOOR LOCKS/REST OPEN CIRCUIT (A)

For Toyota Vans 1983 to 1985.

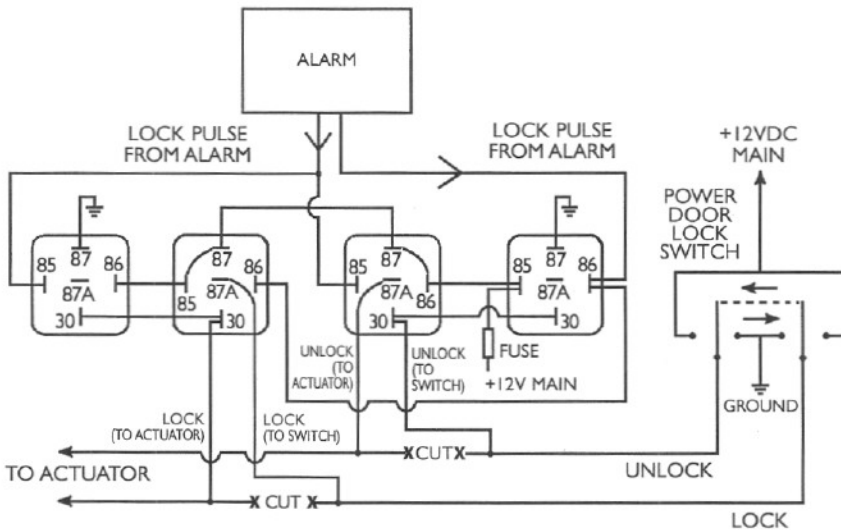

REVERSE POLARITY DOOR LOCK/REST OPEN CIRCUIT(B)

Alarm with (-) outputs.

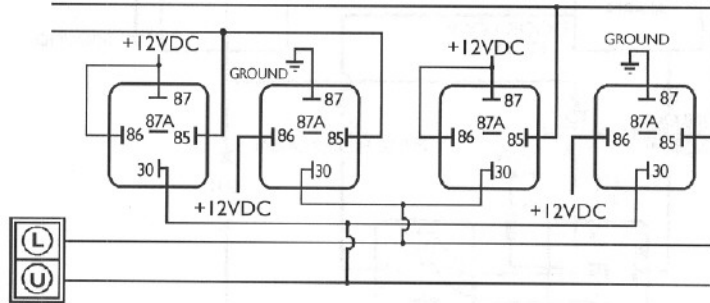

INTERFACE W/DUAL VOLTAGE SYSTEMS - 1994 PROBE

Green/Black wire in door lock module is located in the passenger's kick panel.

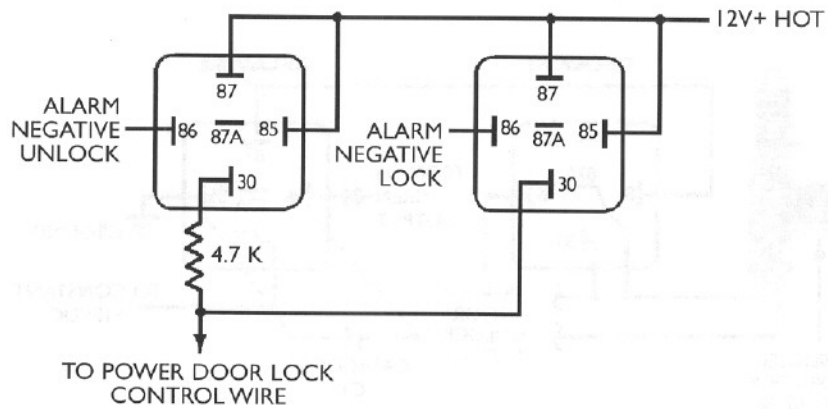

DOOR LOCK SYSTEM USING VACUUM PUMP

Pump is activated by reversing polarity on single lead from door lock cylinder/switch to vacuum pump.

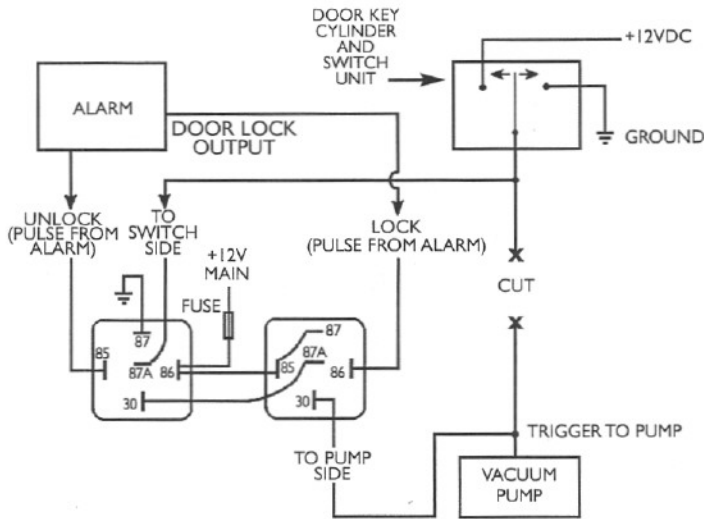

PASSENGER DOOR UNLOCK BYPASS CIRCUIT

The value of CAPACITOR C1 controls how long RELAY #2 will remain energized once the siren chirp(s) stop. This value should be adjusted to make sure RELAY #2 is energized when the door unlock pulse comes through. Start with 4,700 uF, and increase by 4,700uF for every .50 to .75 seconds of delay time desired.

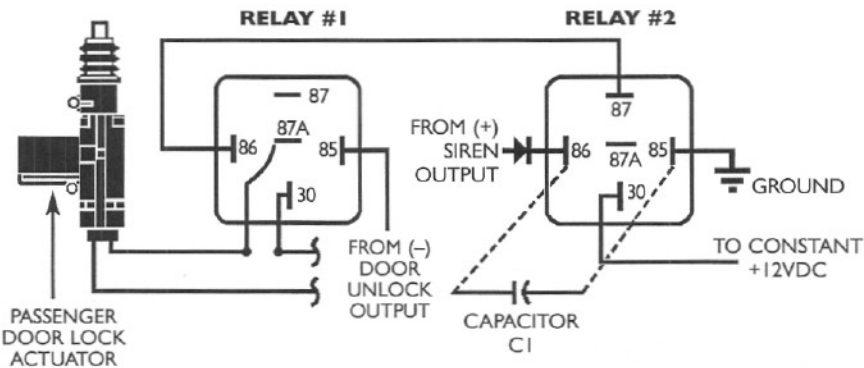

SELECTIVE DOOR UNLOCK/NEGATIVE PULSE SYSTEM

NOTE: HEAVY LINES REPRESENT WIRE THAT IS AT LEAST 16 GAUGE.

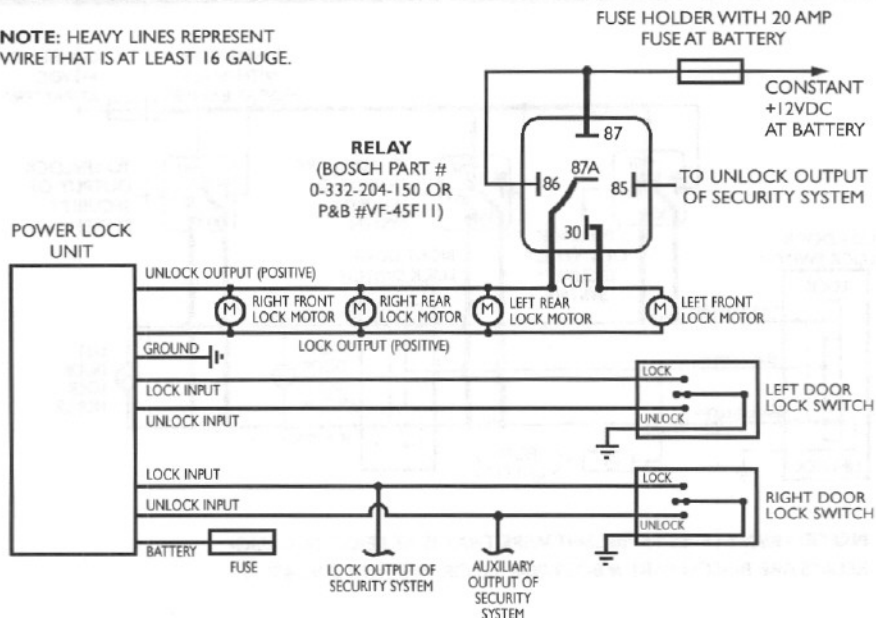

Reprinted with permission from the Installation News 1995 Reference Guide and Fact Book.

SELECTIVE DOOR UNLOCK/POSITIVE PULSE SYSTEM

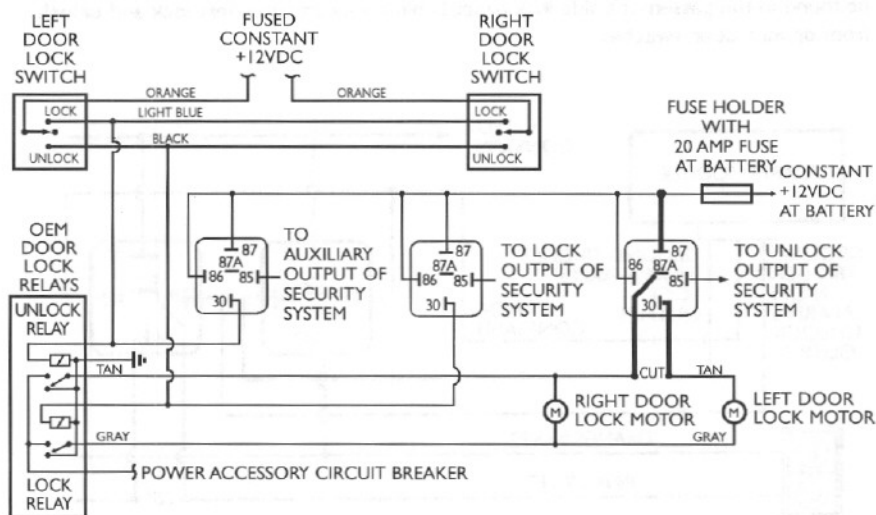

Reprinted with permission from the Installation News 1995 Reference Guide and Fact Book.

SELECTIVE DOOR UNLOCK/REVERSE POLARITY SYSTEM

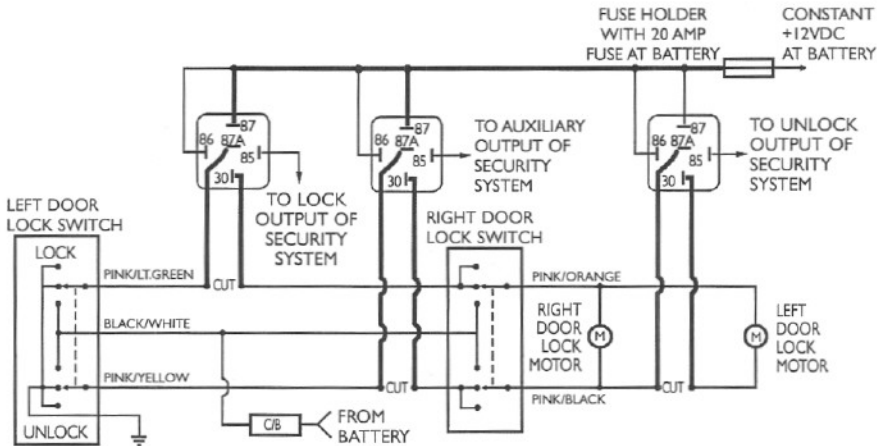

NOTE: HEAVY LINES REPRESENT WIRE THAT IS AT LEAST 16 GAUGE.
RELAYS ARE BOSCH PART # 0-332-204-150 OR P&B PART # VF-45F11

Reprinted with permission from the Installation News 1995 Reference Guide and Fact Book.

SPECIALTY DOOR LOCKS/93 CHRYSLER/DODGE

For 1993 Chrysler LeBaron and Dodge Daytona doors. The lock and unlock wires can be found in the passenger's side kick panel, behind the computer. Test lock and unlock from driver's door switches.

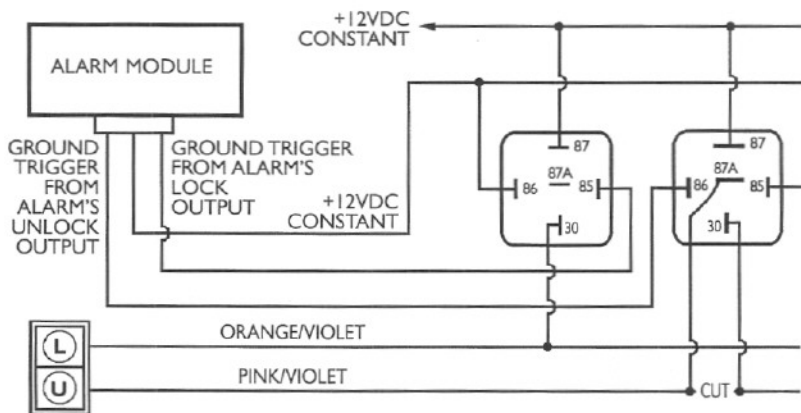

Reprinted with permission from the Installation News 1995 Reference Guide and Fact Book.

SPECIALTY DOOR LOCKS/(-) PULSE/INTERRUPT - NISSAN

(-) pulse to unlock, interrupt circuit to lock.

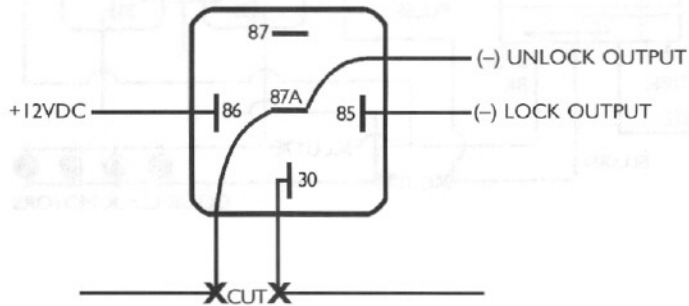

FACTORY LOCK/UNLOCK WIRES
NISSAN '90-'93 240SX: ORANGE/BLACK
NISSAN '92-'93 300SX: BROWN

SPECIALTY DOOR LOCKS/1994 RANGE ROVER

The Range Rover has a one-wire door lock/unlock system. Use a negative pulse to unlock door and intercept circuit through a relay to lock door. Both lock and unlock are located in the driver's kick panel at the 14-pin connector.

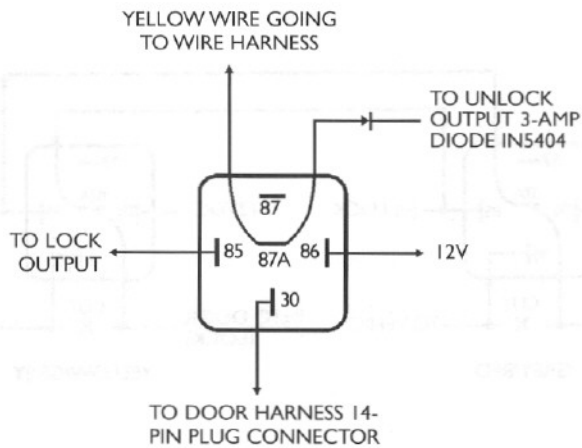

Reprinted with permission from the Installation News 1995 Reference Guide and Fact Book.

SPECIALTY DOOR LOCKS/85-86 TOYOTA VAN

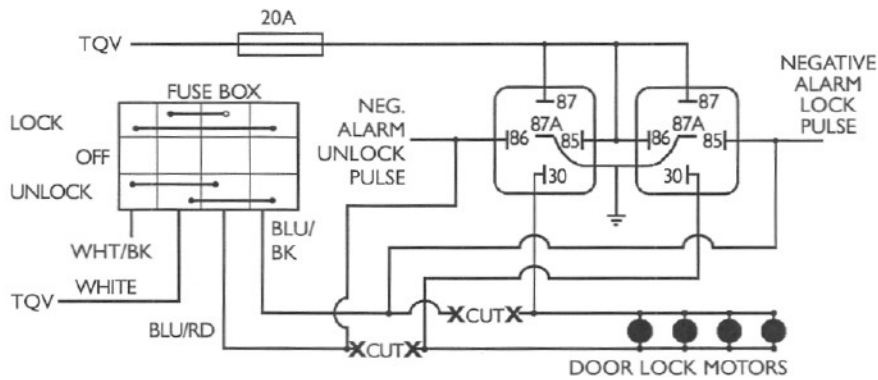

Reprinted with permission from the Installation News 1995 Reference Guide and Fact Book.

SPECIALTY DOOR LOCKS/(-) PULSE/INTERRUPT - VOLVO

For 1995 Volvo 850.

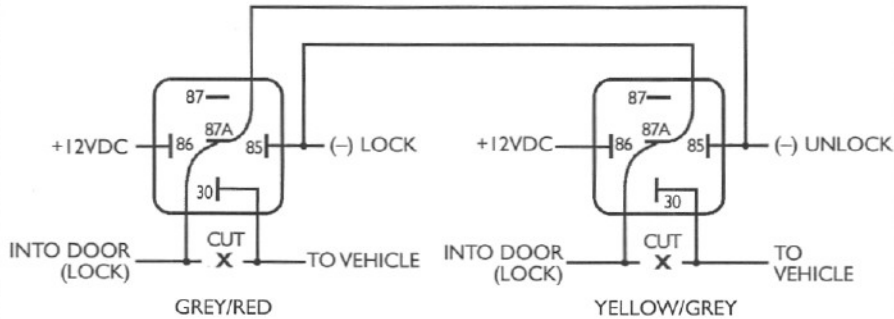

STARTER KILL VIA HIDDEN TOGGLE SWITCH

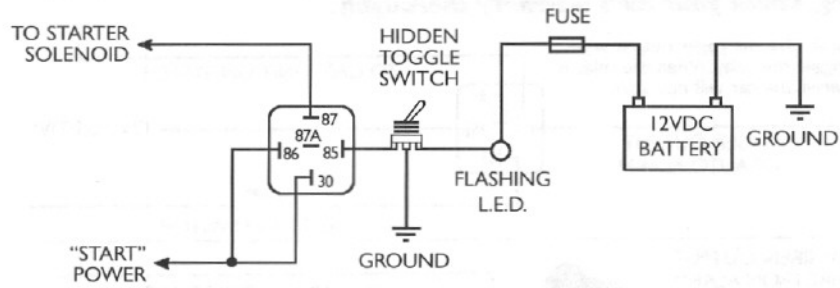

HIDDEN TOGGLE STARTER DISABLE/EXTRA SECURITY

Place fuse in a hidden, but accessible, place for customer to replace. If car is attempted to be started when switch is in ON position, the fuse will blow and car will be unable to start, even if switch is located and placed to the off position.

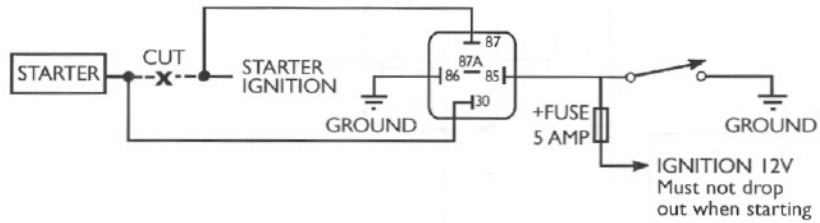

IGNITION KILL CIRCUIT

To prevent car from starting after the alarm has been triggered and until alarm is reset, you can wire a relay to a car's ignition system. **NOTE:** When doing any ignition kill circuitry, it is recommended (when possible) that connections be made at the terminals or connectors, as opposed to splicing into the wiring. This enables you to wire in series rather than interrupting. (Most vehicle manufacturers have some stipulations concerning alterations in ignition system wiring). **Check your car's warranty thoroughly.**

FIG. A Use the pager output wire to trigger the relay. When the relay is triggered, the car will not start.

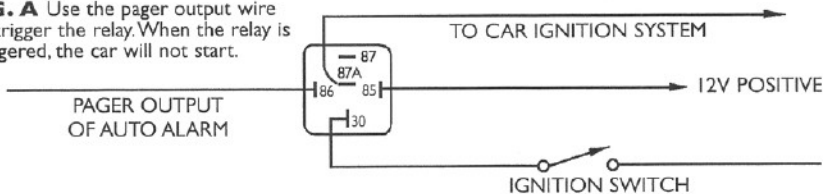
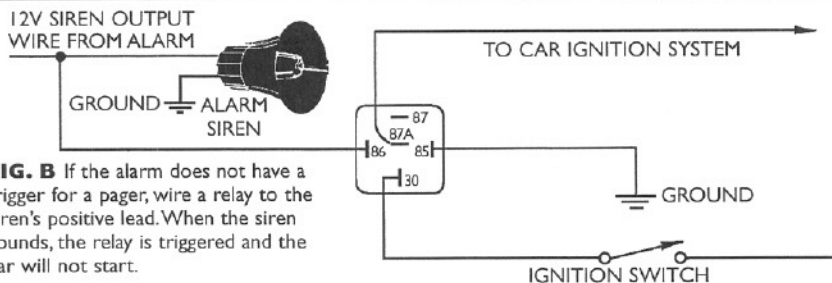
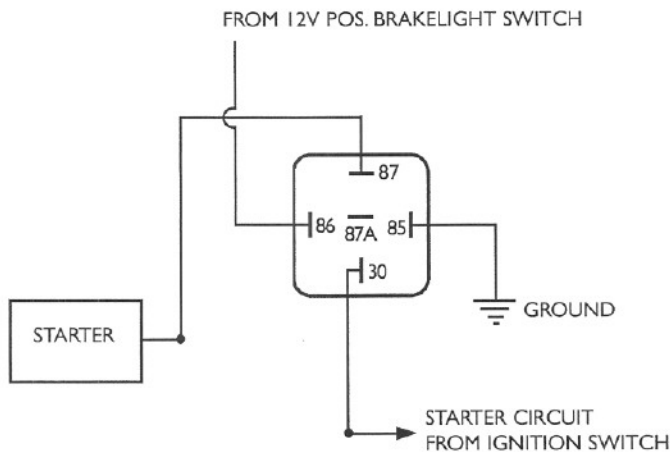

FIG. B If the alarm does not have a trigger for a pager, wire a relay to the siren's positive lead. When the siren sounds, the relay is triggered and the car will not start.



SAFETY STARTER CUT-OFF

Starter cut-off using brake switch. Step on brakes while cranking car.



STEALTH STARTER INTERRUPT

This basic security system uses any positive switching accessory (brake, parking light, high beams, etc.) to allow or not allow the vehicle to start. If the accessory used is not engaged before and during the cranking of the engine, the horn will sound and the starter will not operate.

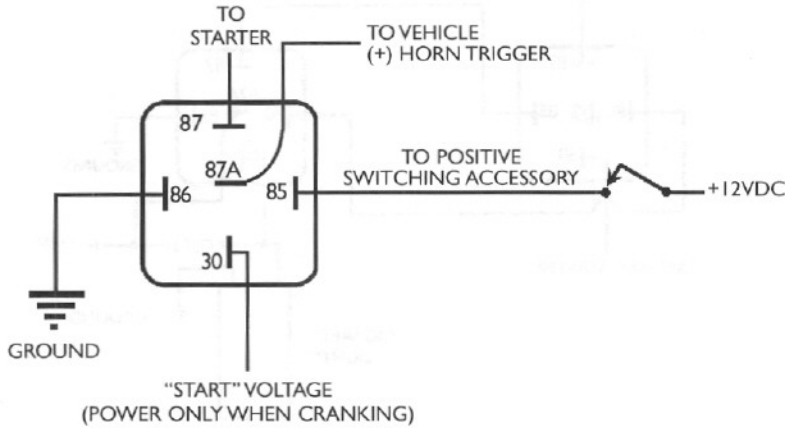

STARTER DISABLE/CIGARETTE LIGHTER INOPERATIVE

This diagram uses a Cigarette Lighter as a ground activated switch:

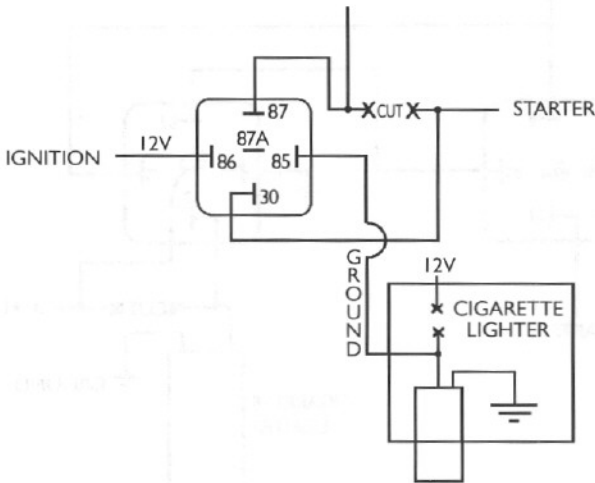

STARTER DISABLE/CIGARETTE LIGHTER OPERATIVE

This circuit uses a cigarette lighter as a ground activated switch for a starter disable, without disabling the use of the cigarette lighter.

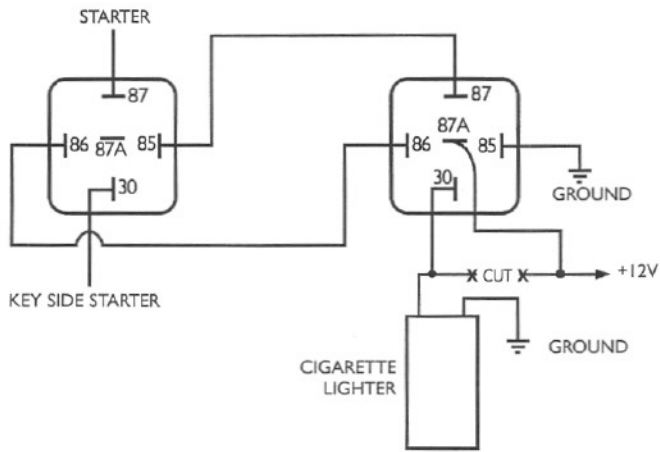

KEYLESS ENTRY W/CIGARETTE LIGHTER/EXTRA SECURITY

In this circuit the cigarette lighter must be pushed-in and the headlights must be turned on in order for the car to start. This also enables the use of the cigarette lighter.

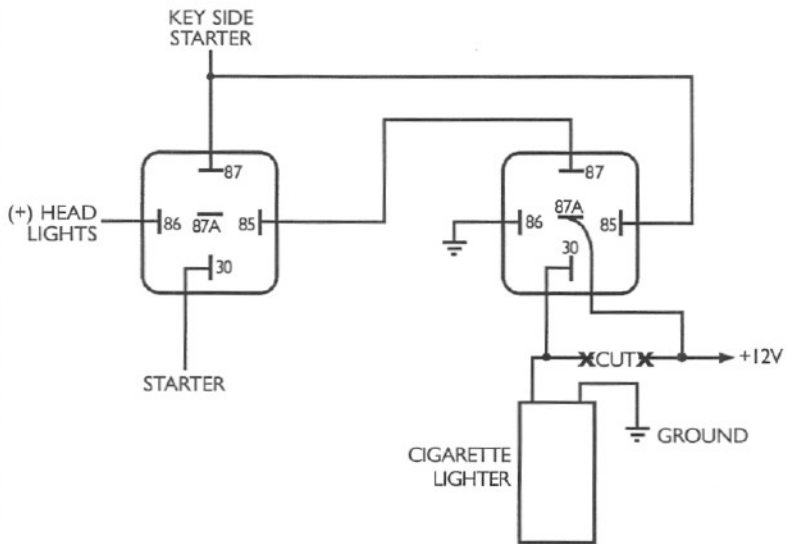

ALARM TRIGGER INVERTER

Most alarms on the market have both a positive and a negative trigger. Although both are supplied, sometimes only ONE type of trigger can be wired. If you have a car that switches 12V to a dome light and you want to install a motion sensor that supplies a ground, you must invert one of the signals. (i.e. The grounding motion sensor to a 12V sensor.)

FIG. A Switches a grounding dome light to a 12V sensor output.

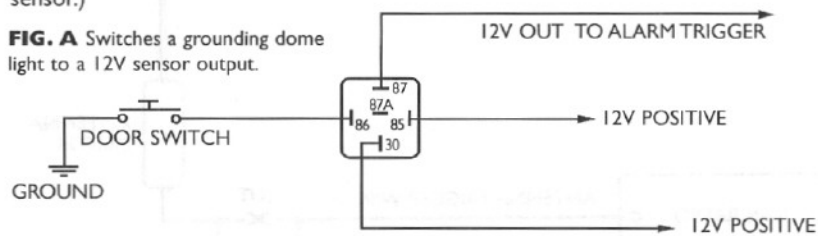
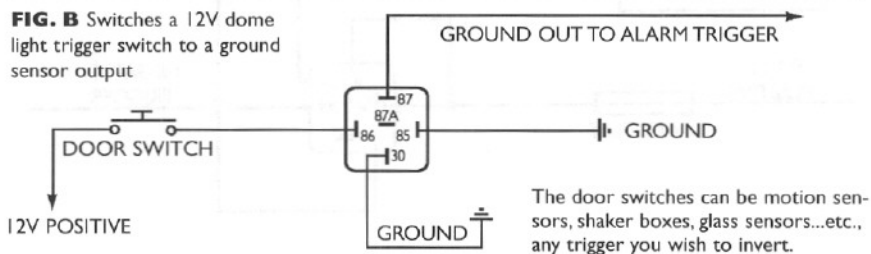
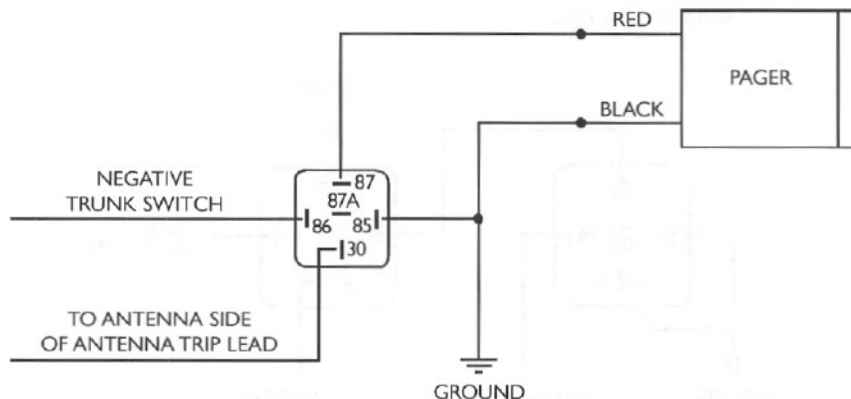

FIG. B Switches a 12V dome light trigger switch to a ground sensor output



The door switches can be motion sensors, shaker boxes, glass sensors...etc., any trigger you wish to invert.

ADDING A PAGER TO AN EXISTING ALARM



ALARM PAGER ANTENNA DRIVER

This diagram shows how to raise a power antenna with a negative alarm trigger in order to send out a pager signal and prevent 12V feedback.

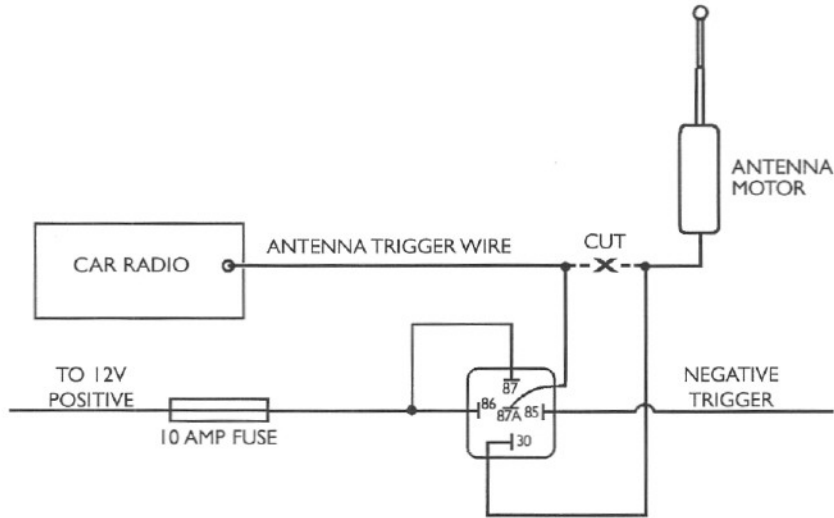

FACTORY HORN HONK WITH SILENT ALARM

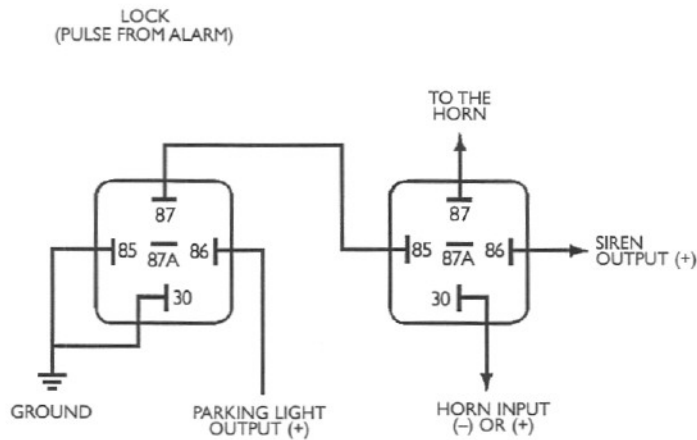

FAKE ALARM FLASHING L.E.D.

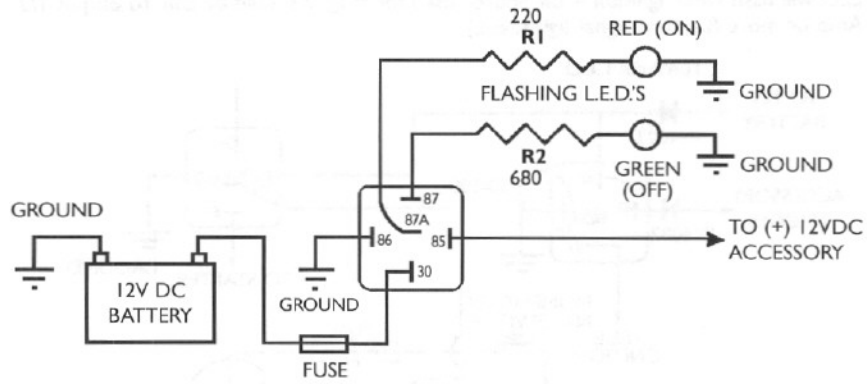

NOTE: Any color L.E.D.'s can be used instead of the red and green indicated in the diagram.

IGNITION SENSING L.E.D.

L.E.D. will flash when ignition is switched off.

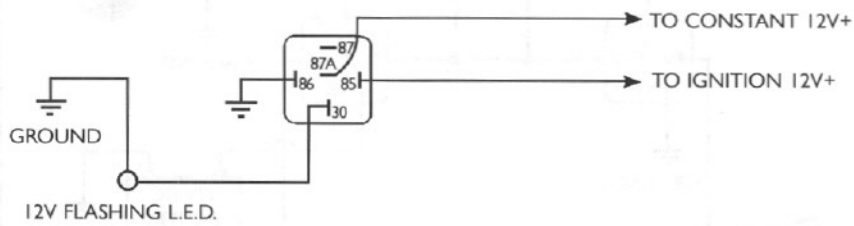

SIMPLE AUTO ALARM

A momentary 12 volt pulse to the accessory trigger input allows vehicle to start. If no pulse is applied, horn will honk until momentary switch is pressed, breaking the latch. LED will flash when ignition is off. Source used for trigger should be able to output 1/2 Amp or more (i.e. turn signal, lights, etc.)

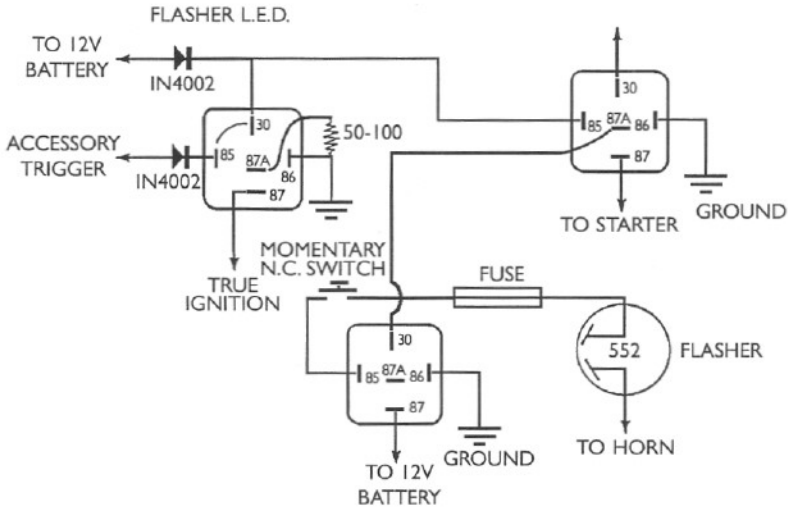

CHEAP, BUT DEPENDABLE CAR ALARM

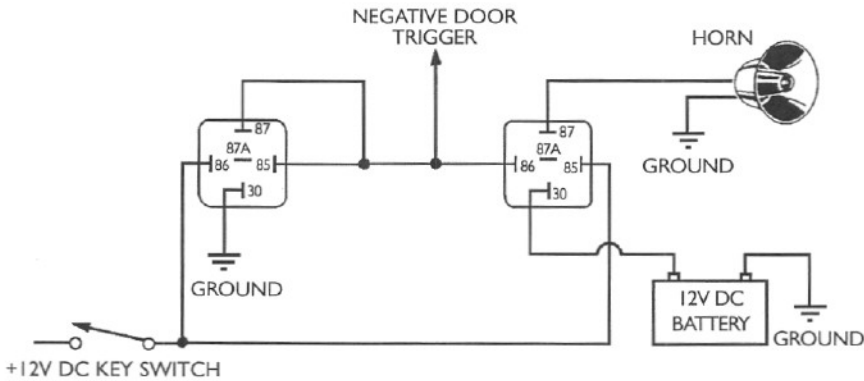

ALARM FOR MOTORCYCLE

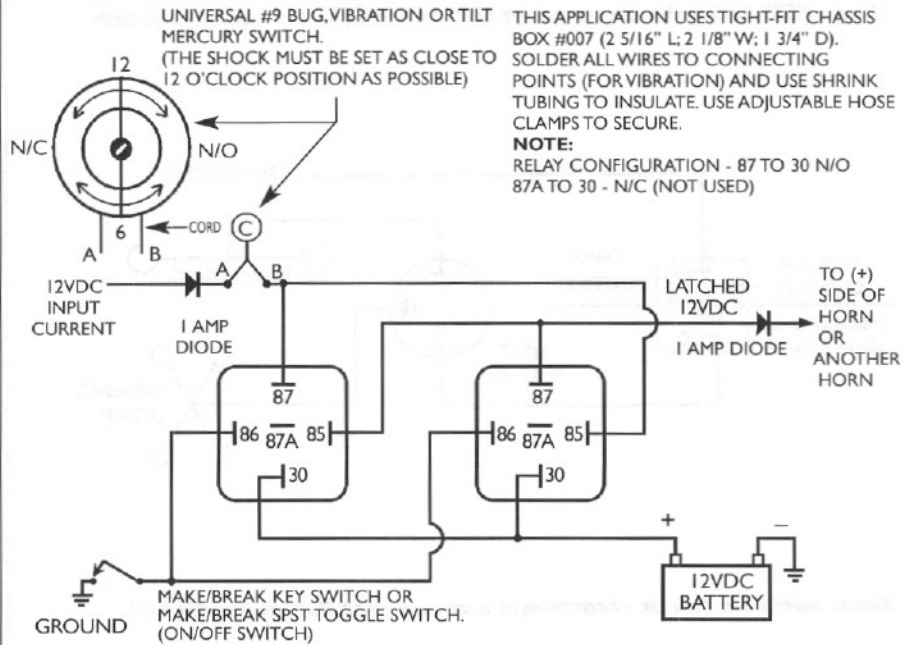

PARKING LIGHT FLASHING CIRCUIT

This circuit will work with most American, Japanese and Korean cars.

See diagram "Two-Way Flasher" on next page for headlights.

Do not try this circuit to flash headlights as this may cause headlights to burn-out.

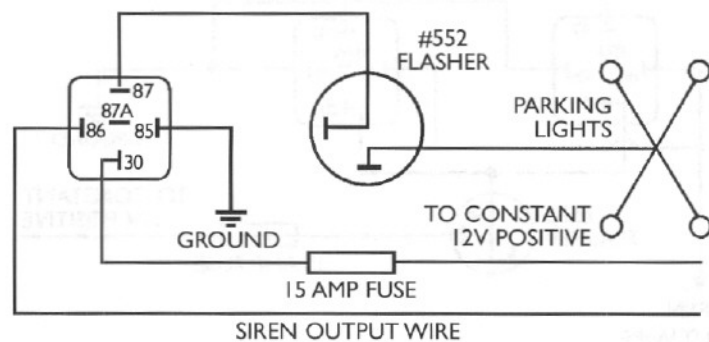

TWO WAY FLASHERS

Using a #537 flasher, this circuit enables both parking lights and headlights to flash.

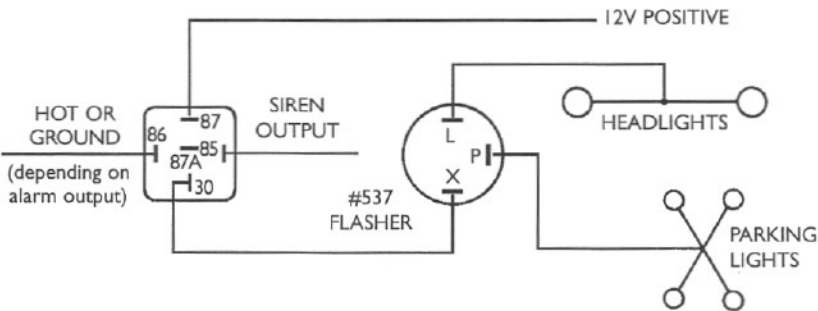

Some installers do not recommend a circuit that flashes headlights!

FLASHER CIRCUIT FOR EUROPEAN CARS

This circuit, using two relays, will work with BMW, Audi, Saab, Mercedes Benz, Jaguar and Rolls Royce. Make sure the car's parking light circuits are independent. (i.e., left from right). Always install a 15 Amp in-line fuse as shown.

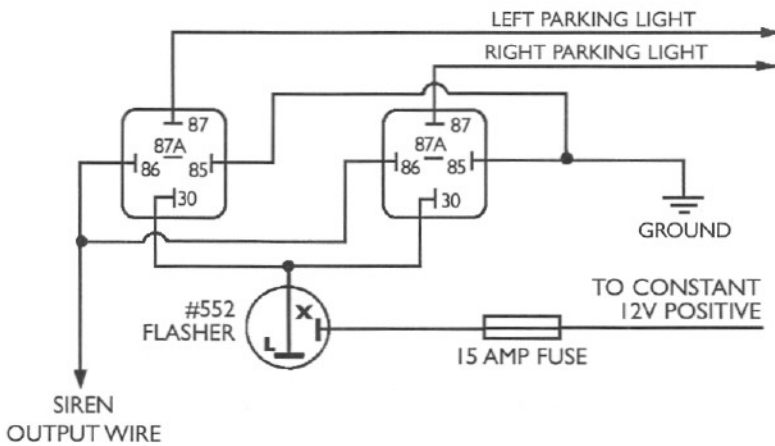

SEPARATE LEFT/RIGHT PARKING LIGHT CIRCUITS (A)

DIAGRAM A: This diagram illustrates an alarm that has current limitation (no on-board relay) positive (+) parking light output.

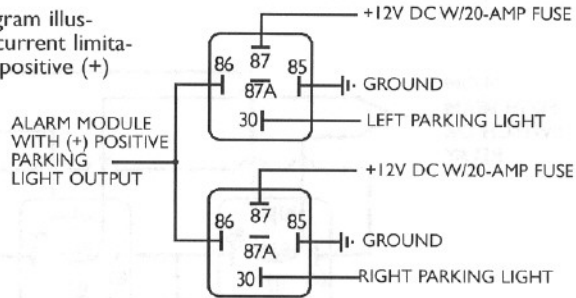
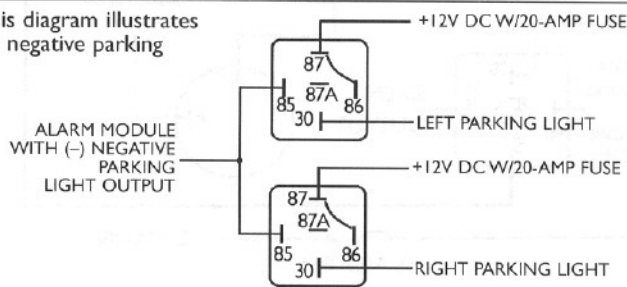

DIAGRAM B: This diagram illustrates an alarm that has a negative parking light output.



Reprinted with permission from the Installation News 1995 Reference Guide and Fact Book.

SEPARATE LEFT/RIGHT PARKING LIGHT CIRCUITS (B)

DIAGRAM C: This diagram illustrates how to wire a relay that has 2 separate output terminals to isolate left and right parking lights. This application requires a "Green Slash" dual make SPST Relay.

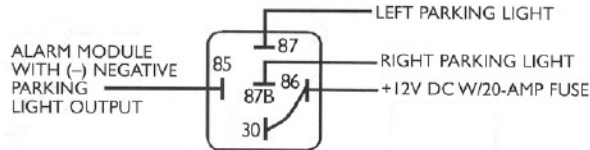
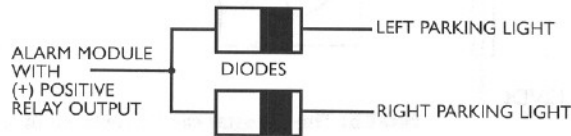
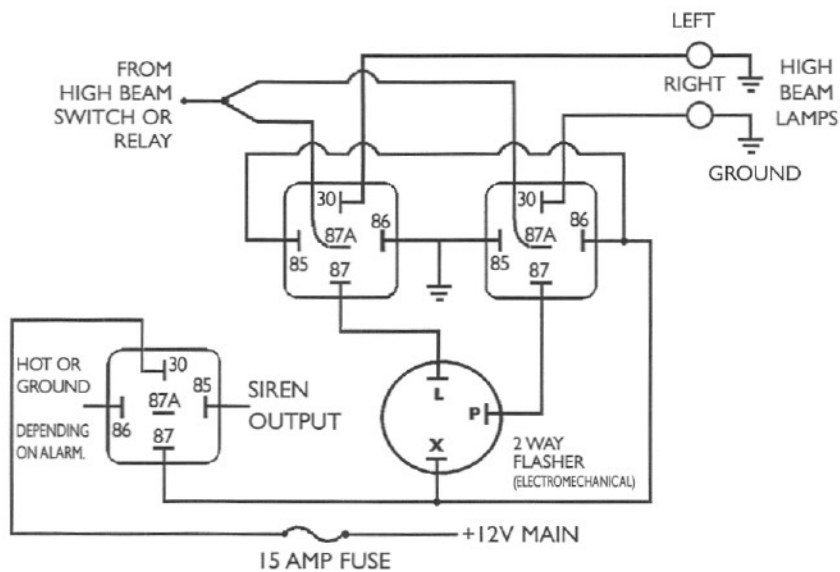

DIAGRAM D: This diagram illustrates how to wire 2 diodes to isolate left and right parking lights with an alarm that provides a positive (+) relay output. Consult owners manual for the value of the parking circuit, and determine diode amperage (Minimum value: 6 Amps).



Reprinted with permission from the Installation News 1995 Reference Guide and Fact Book.

LEFT TO RIGHT FLASHING HIGH BEAMS



LEFT TO RIGHT FLASHING LIGHTS

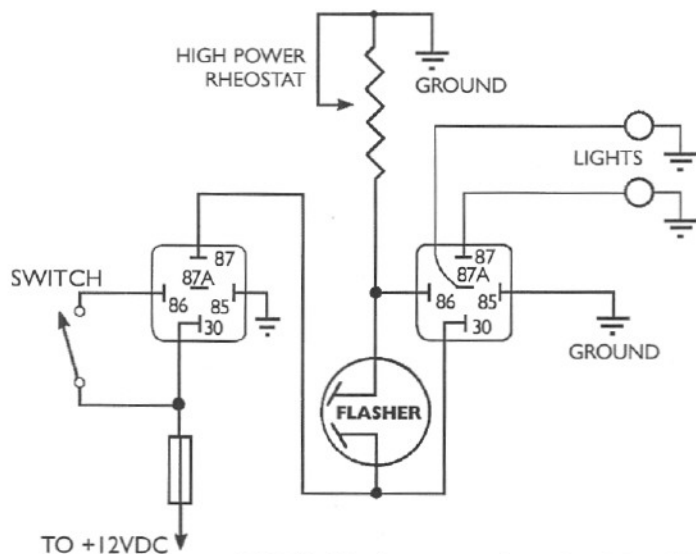

NOTE: The rheostat can be replaced by a 12V bulb. If this is done the flash rate cannot be adjusted.

HORN HONK/LIGHT FLASH CIRCUIT

FIG. A

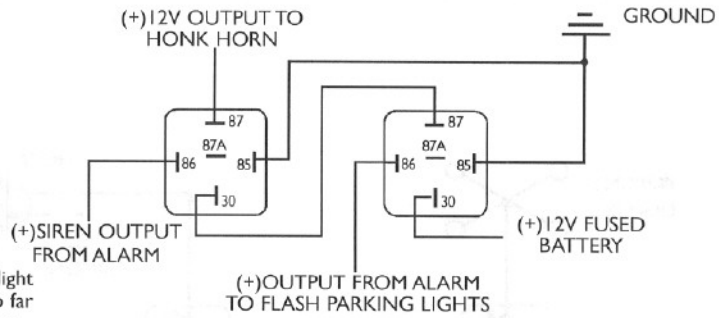

If the siren chirp/light flash pulses are too far apart, horn honking circuit will not honk horn every time siren chirps.

FIG. B

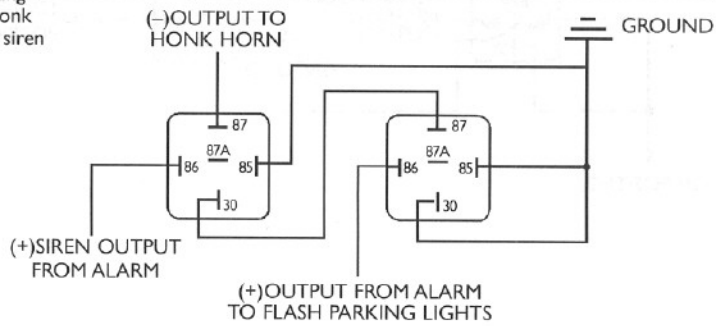

FLASHER HONKER CIRCUIT

For positive output and flipped-negative output, this application enables you to flash the parking lights and honk the horn.

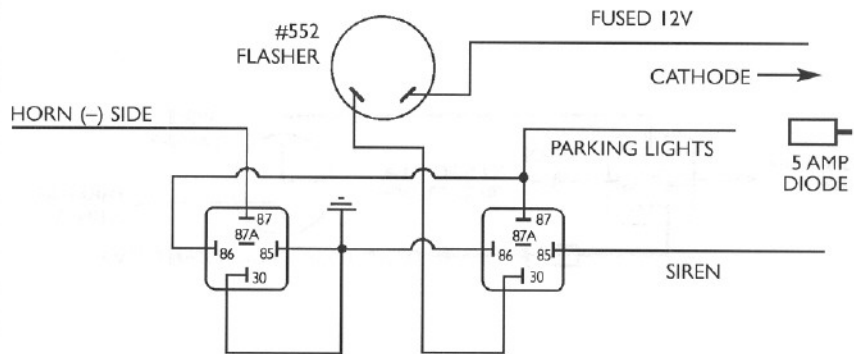

ALTERNATELY FLASHING PARK LIGHT/HORN

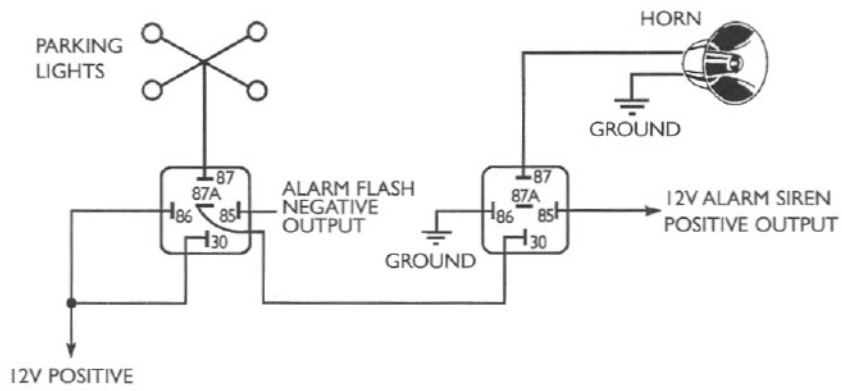

PARKING LIGHT SAFETY FLASHER

When car is running and the doors have been opened to pickup or discharge passengers, the parking lights automatically flash.

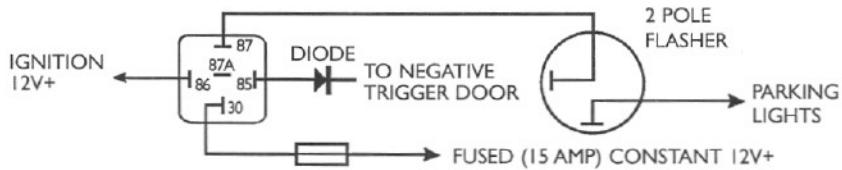

WIPERS TURN ON PARKING LIGHTS & HEADLIGHTS

Wipers turn on parking lights along with headlights (The law in some states).

Positive Version

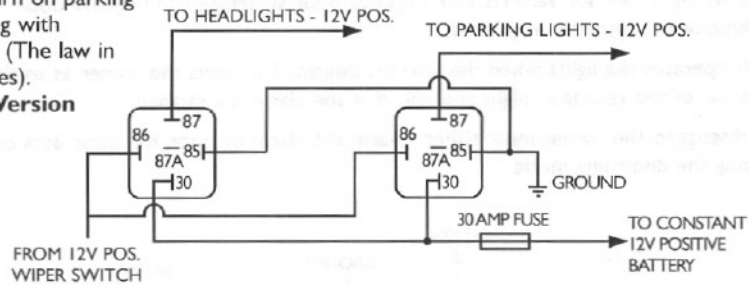

Negative Version

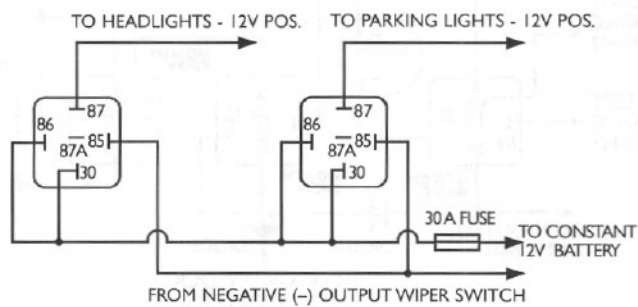

WIPERS/LIGHTS TURN-ON TOGETHER

With this circuit, the headlights and windshield wipers turn on together.

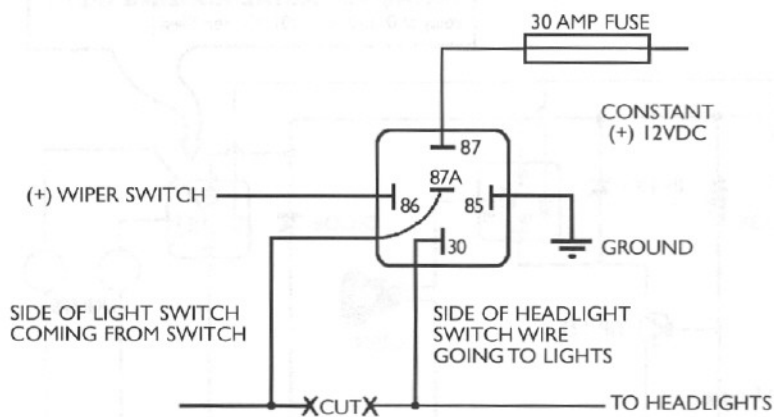

COURTESY/CAR IDENTIFIER LIGHTS

This wiring is only for vehicles with negative door switching and negative door lock/unlock output alarm systems.

Unit operates the lights when the alarm is disarmed. It alerts the owner as to the location of the vehicle at night and also that the alarm is disarmed.

To disengage, the owner must either re-arm the alarm or open the door, thus completing the disarming mode.

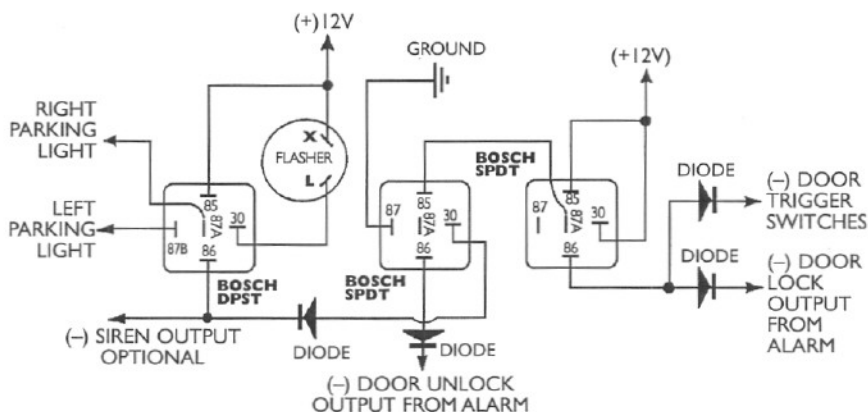

AUDIBLE "CHIRP" TO VISUAL "BLINK" CONVERSION

For customers who don't like the "CHIRP" sound made by the alarm when arming and disarming, use the diagram below to convert a chirping alarm to a blinking alarm.

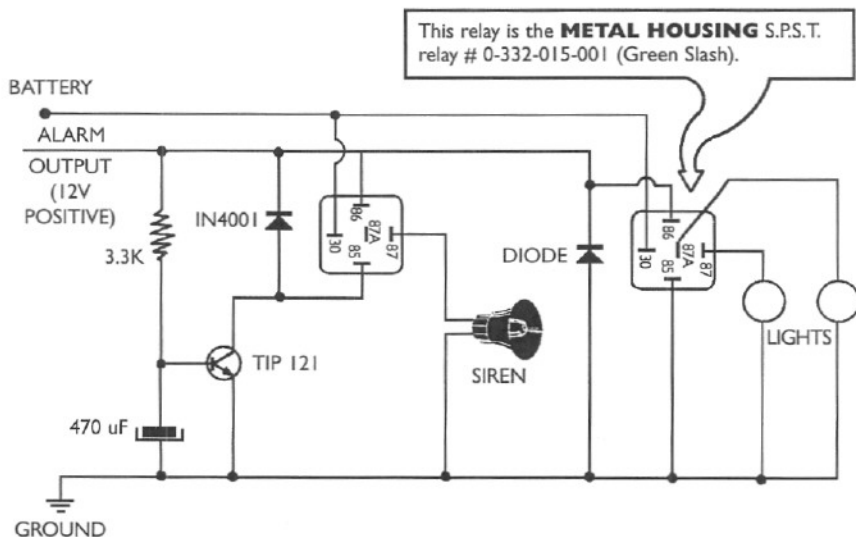

FLASHER L.E.D. TO LIGHT FLASH CONVERTER

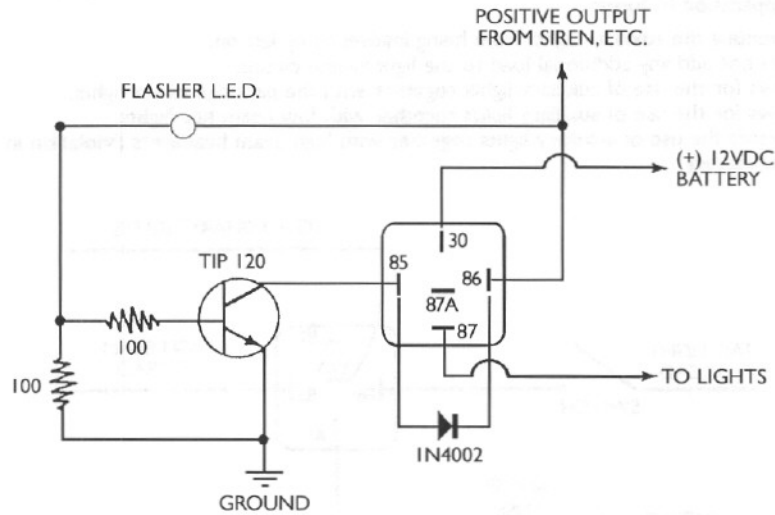

BASIC FOG LIGHT SYSTEMS

The two diagrams below show how to control and isolate low-current switches to high-current fog lights.

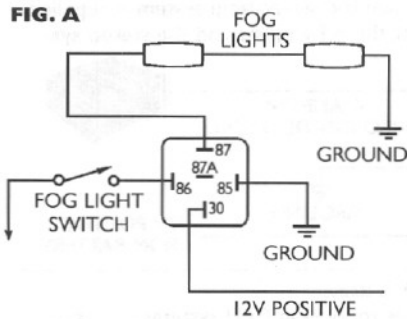

FIG. A A dash switch is closed, triggering the relay to close and the fog lights to turn on with high-current power from the battery.

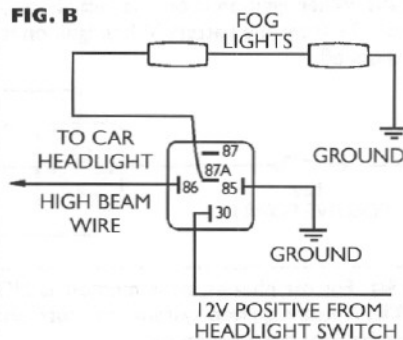

FIG. B Relay is connected to high beam of car lights so when beams are on, fog lights are off. When low beams are on, fog lights also turn on. When all headlights are off, fog lights shut off.

NOTE:

Fog lights will turn on with headlights but will shut off when high beams are used.

AUXILIARY FOG LIGHT CONTROL

This diagram makes use of one relay to control the operation of auxiliary fog lights. This application features:

1. Preventing the auxiliary lights from being inadvertently left on.
2. Does not add any additional load to the light switch circuit.
3. Allows for the use of auxiliary lights together with the parking/marker lights.
4. Allows for the use of auxiliary lights together with low beam headlights.
5. Prevents the use of auxiliary lights together with high beam headlights (Violation in some states)

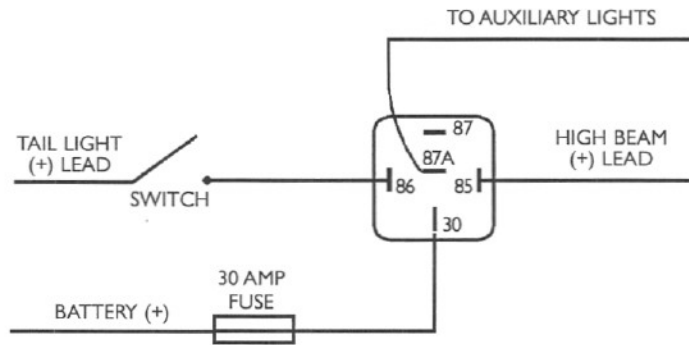

IGNITION BYPASS TO ELIMINATE NOISE

On some import or older model cars, the vehicle's ignition or charging system can cause noise to be picked up by high end audio systems or cellular phones. To eliminate this noise, use the following 2 diagrams.

FIG A: When ignition is on, the relay is closed and the stereo/amp system is supplied a clean 12V from the battery. When ignition is off, the relay opens and the stereo system shuts off.

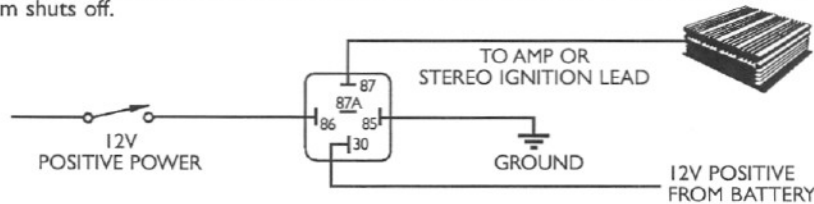
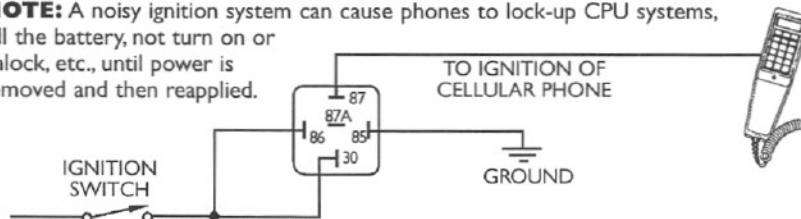

FIG B: For car phones, same method as FIG.A is used.

NOTE: A noisy ignition system can cause phones to lock-up CPU systems, kill the battery, not turn on or unlock, etc., until power is removed and then reapplied.



AMP SYSTEM REMOTE POWER SWITCH

The diagram below displays a remote turn-on system. When the radio is turned on, the relay is triggered. When the radio is turned OFF, the system shuts down. When the radio is on, the relay closes, the amp or E.Q. system turn-on wires receive 12V power, then the system turns on.

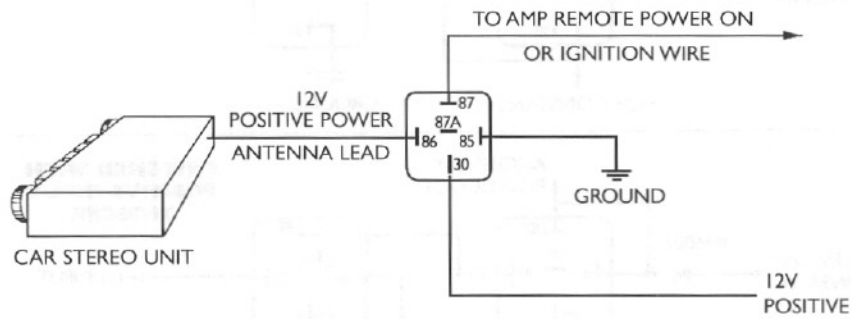

SWITCHING MODULE

Cut and use L(+) of RCA cable to Bosch Relay #1; R(+) to Bosch Relay #2. All RCA L(+) together; all RCA R(+) also. Remote from radio to turn-on AMPS and EQ. Remote from CD to turn on relays only.

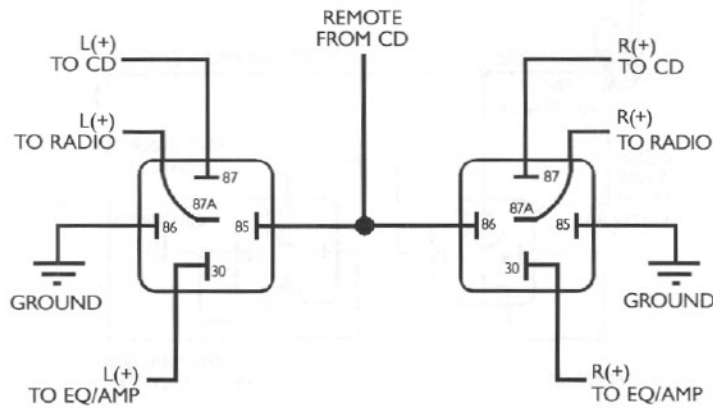

ACCESSORY POWER BACK-UP CIRCUIT

This back-up circuit was developed to maintain accessory power until ignition is turned off and one of the doors is opened. This circuit can be used for cellular telephones, radios, etc.

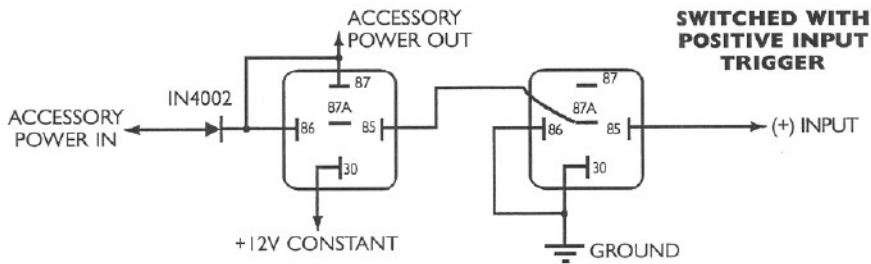
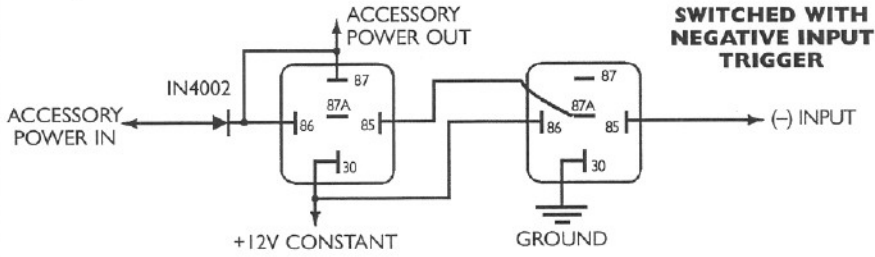

AUTOMATIC ANTENNA SWITCHING RELAY

This application is used for the 280ZX with antenna switch or any other vehicle with a positive trigger switch that controls a semi-automatic antenna.

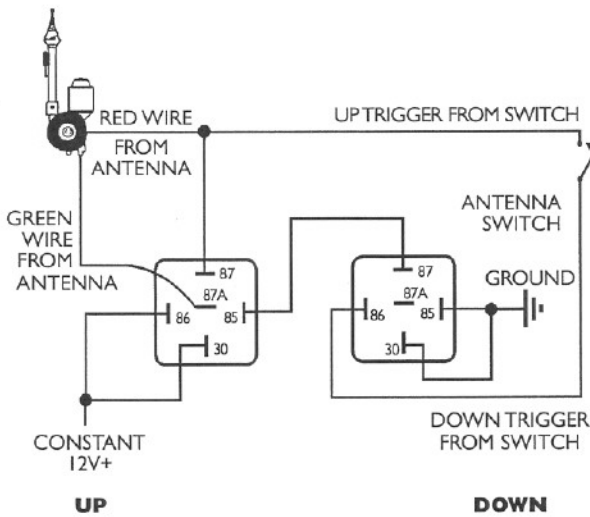

AUTO ANTENNA PROTECTOR

With an automatic antenna mounted near the rear trunk, potential hazard sometimes exists to antenna when opening trunk. This simple circuit will solve the problem.

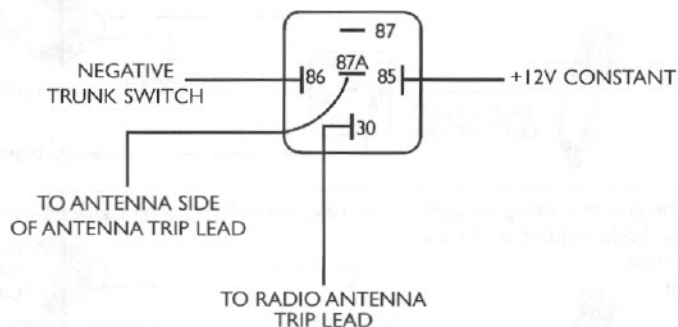

STEREO DISABLE WITH CIGARETTE LIGHTER

The following diagram shows how to wire the switched power lead from the deck through the cigarette lighter via a Bosch relay. With the lighter pushed in, the relay grounds and activates the head unit. When the lighter is pulled out or removed, the deck loses switched power and is disabled. The constant 12V is still wired and the deck loses no memory of station pre-sets.

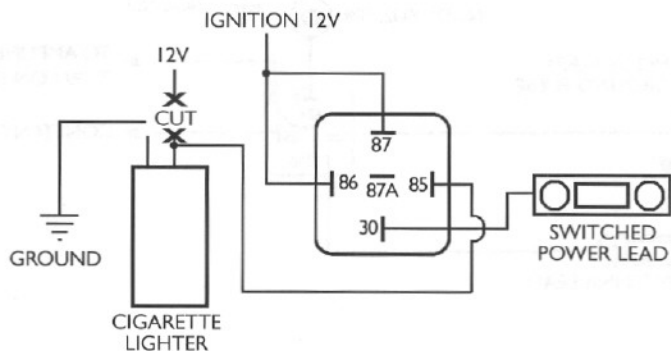

HORN ALERT FOR CELLULAR PHONES

Most cellular phones on the market today have a horn alert option. When wired-up to a car's horn, the horn alert will sound the horn when a call is received. (The "ring" key on the phone must be in the OFF position so that the phone "knows" you are out of the car.)

NOTE: The phone alert wire supplies a low-current ground that must be isolated and sometimes converted, depending on the style of the car horn.

FIG A: The phone is being isolated by the relay and a high current 12V being supplied by the battery going to the car horn's switched power lead.

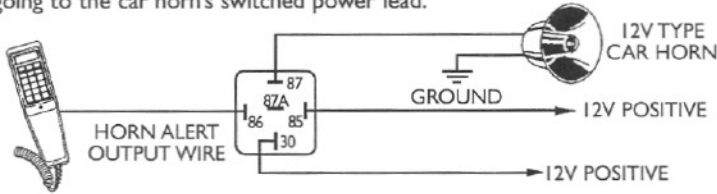
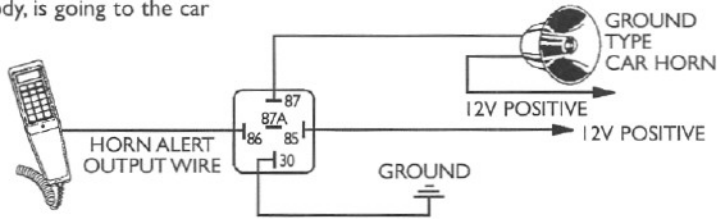
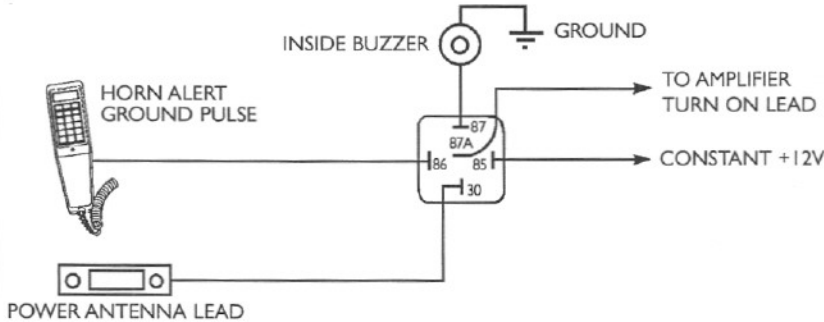

FIG B: The phone is being isolated by the relay and a high current ground coming from the car body, is going to the car horn's switched ground lead.



HORN ALERT WITH BUZZER

When horn alert is activated, amp will shut off with each pulse at the same time inside buzzer will turn on.



NOTE: Power antenna lead output must have sufficient current to operate buzzer.

SIMPLE LATCH (-) TURN ON, (+) TURN OFF/(-) OUTPUT

Use to allow ground pulse from remote of alarm to turn on accessory device, and any (+) switched source to turn accessory device off. EG. remote turns on neon, pressing brake pedal turns neon off.

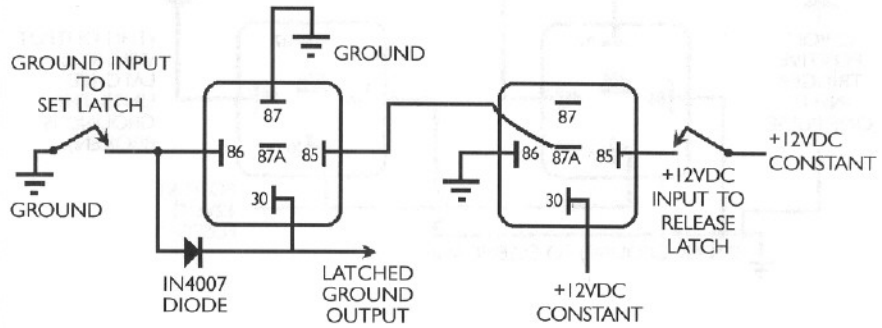

SIMPLE LATCH (-) TURN ON (-) TURN OFF (+) OUTPUT

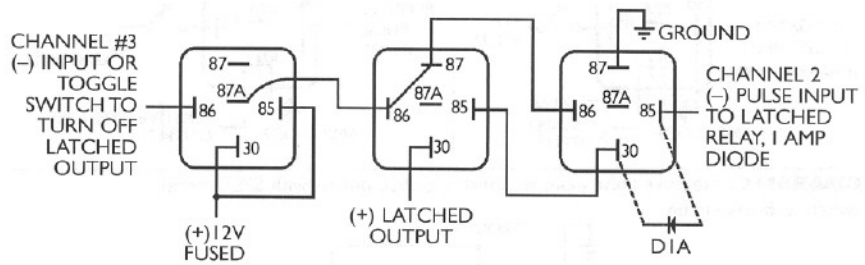

SIMPLE LATCH (+) TURN ON, REMOVE (-) TURN OFF, (+) OUTPUT

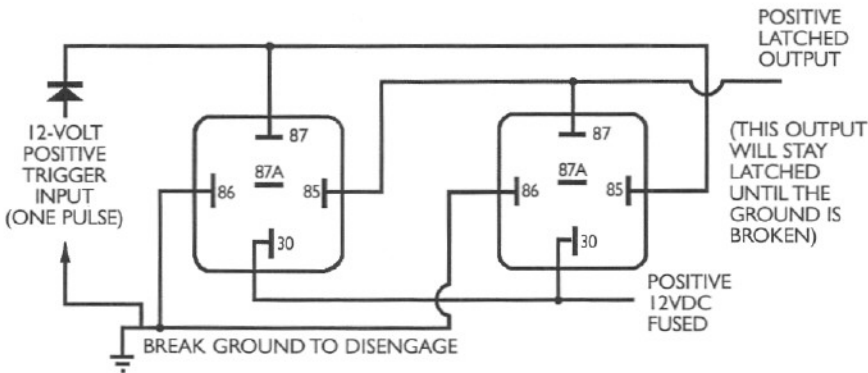

*DIODE IN THIS DIAGRAM IS OPTIONAL.

Reprinted with permission from the Installation News 1995 Reference Guide and Fact Book.

OPTIONAL METHODS OF LATCHING RELAYS (I)

DIAGRAM A: Negative pulse input (channel two from alarm) to continual negative latched output with SPST toggle switch to break circuit.

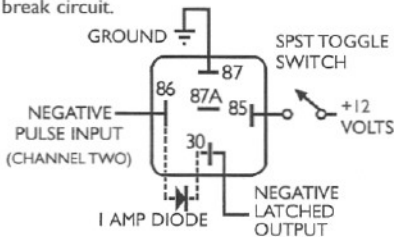

DIAGRAM B: Positive pulse input to continual positive latched output with SPST toggle switch to break circuit.

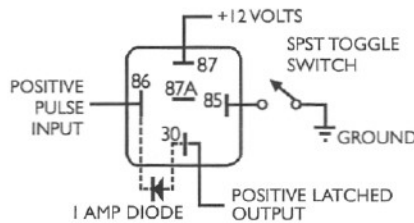
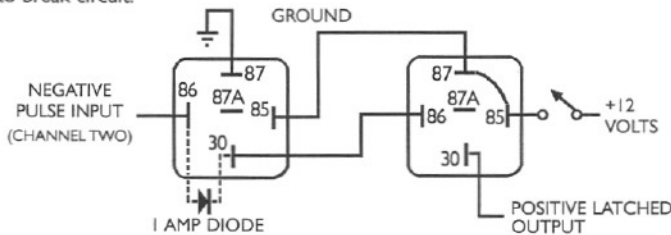

DIAGRAM C: Negative pulse input to positive latched output with SPST toggle switch to break circuit.



Reprinted with permission from the Installation News 1995 Reference Guide and Fact Book.

OPTIONAL METHODS OF LATCHING RELAYS (2)

DIAGRAM D: Negative pulse input to positive latched output with brake switch (or any other positive trigger) to open circuit. This can be used to turn on interior lights (in vehicles with positive interior lights) or headlights.

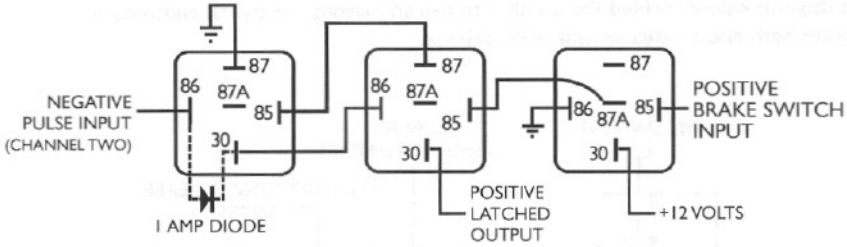
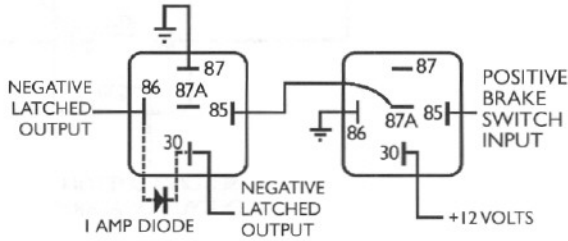
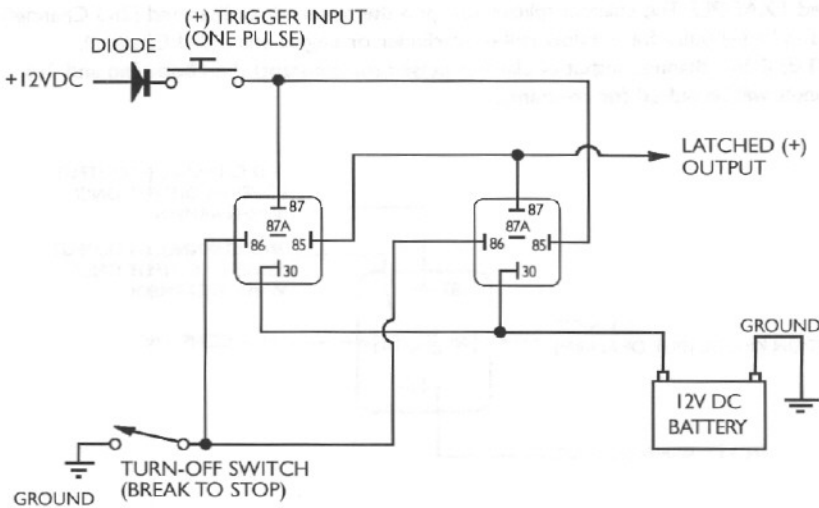

DIAGRAM E: Negative pulse input to negative latched output with brake switch (or any other positive trigger) to open circuit. This can be used to turn on interior lights (in vehicles with positive interior lights) or headlights.



Reprinted with permission from the Installation News 1995 Reference Guide and Fact Book.

LATCHING TRIGGER ALARM



TRANSFER FUNCTION OF A RELAY

By using this circuit you can make the second button on your alarm transmitter perform two functions.

The diagram below enabled the installer to use an existing pin switch and relay to operate both linear actuator and trunk release.

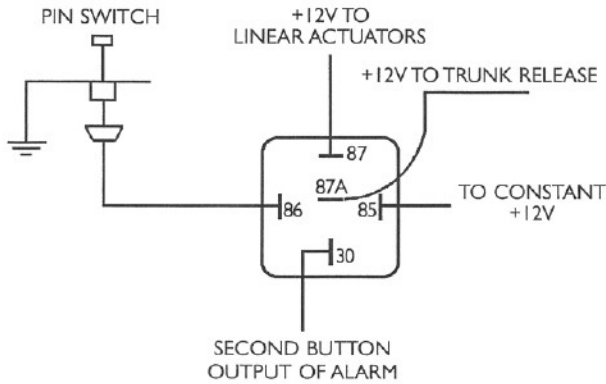

THIRD FUNCTION AUXILIARY CHANNEL

This feature provides an auxiliary channel that can operate a third function only when armed. **EXAMPLE:** The channel splitter can: pop the trunk when disarmed (2nd Channel) and send a (-) pulse for window roll-up, carfinder, or engine start (3rd Channel).

NOTE: If 2nd channel output of alarm is pulsed (or constant) then both 2nd and 3rd channels will be pulsed (or constant).

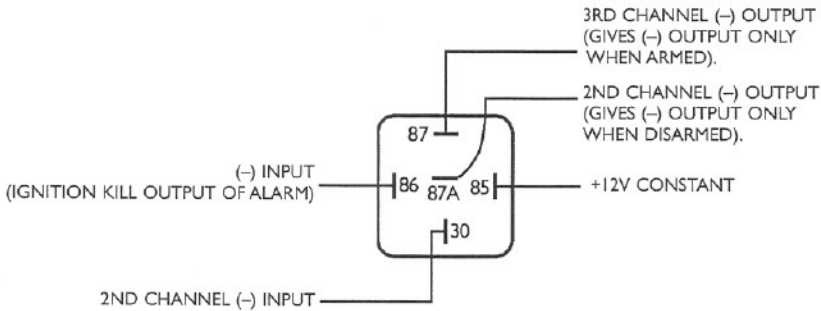

DUAL FEATURE AUXILIARY SWITCH

When ignition key is on, auxiliary will turn on stereo. When key is in off position, auxiliary opens trunk.

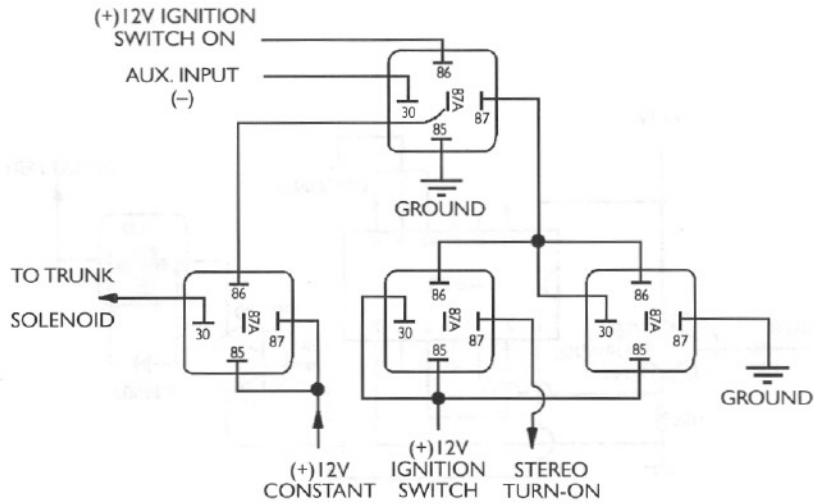

CHANNEL SPLITTER (ARMED/DISARMED)

Alarm with one output is converted to two.
EXAMPLE: To open trunk when alarm is disarmed.

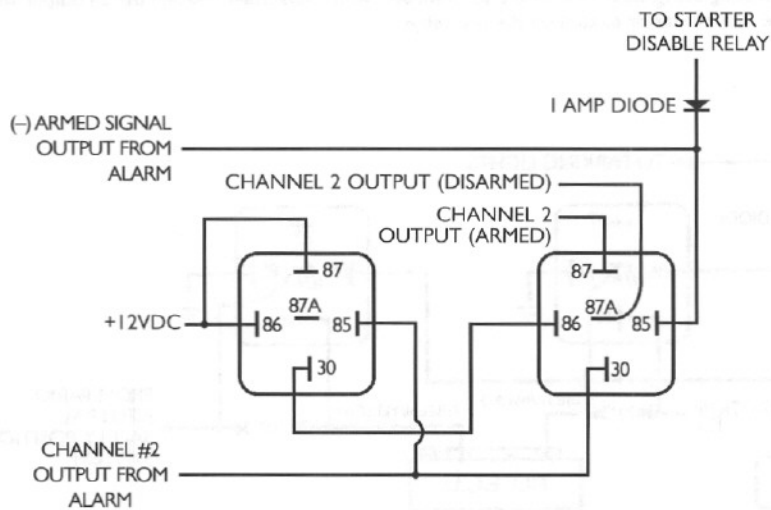

PULSE-ON/PULSE-OFF RELAY

This circuit eliminates any possibility of erratic operation found in mechanical switches.
(Eliminate inverter transistor if using positive trigger)

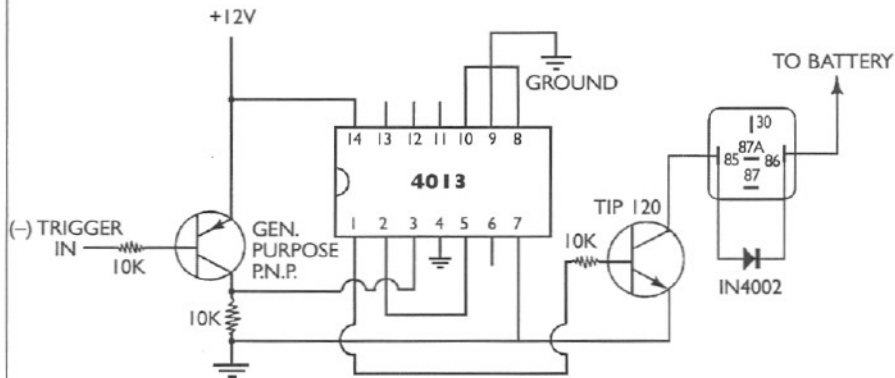

STEERING WHEEL TILT USING A REMOTE STARTER

The 1993 and 1994 Lexus GS-300 factory automatic tilt steering wheel can be made to go down after a remote starter has been activated. To do this, it is necessary to fool the tilt E.C.U. computer by interrupting the ignition wires at the tilt computer with relays. Then, find and use an output wire from the remote starter to turn on the two relays.

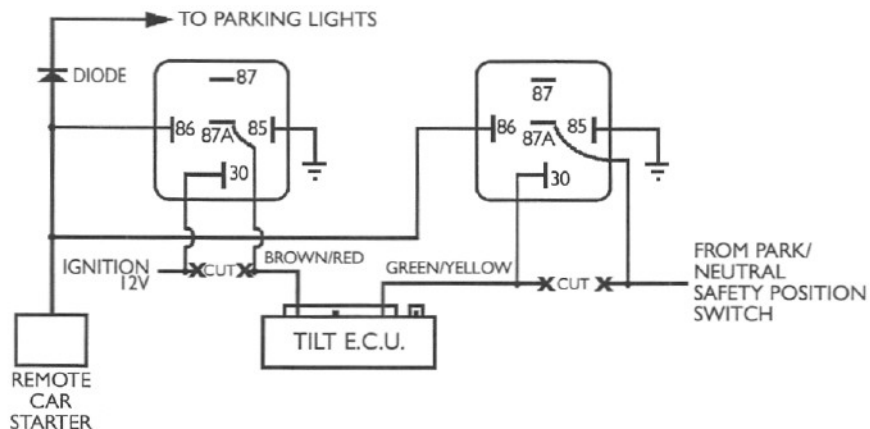

THE "POOR PERSON'S" KEYLESS ENTRY

Used in circumstances when doors are closed and keys left in ignition accidentally. Hide a magnetic reed switch inside the car (i.e. inside a parking light or near a window) and then, when needed, use the magnet to run over the hidden reed switch, unlocking the automatic door locks. This application is used in conjunction with an alarm. When this application is used, the alarm will sound, but it is a good reminder not to leave your keys in your car.

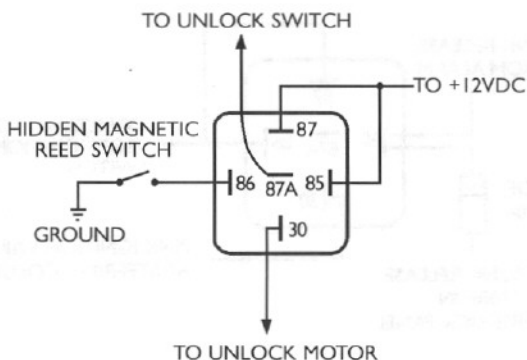

POWER TRUNK RELEASE WITH POSITIVE PULSE

If the power trunk release requires a positive pulse to operate, use this circuit.

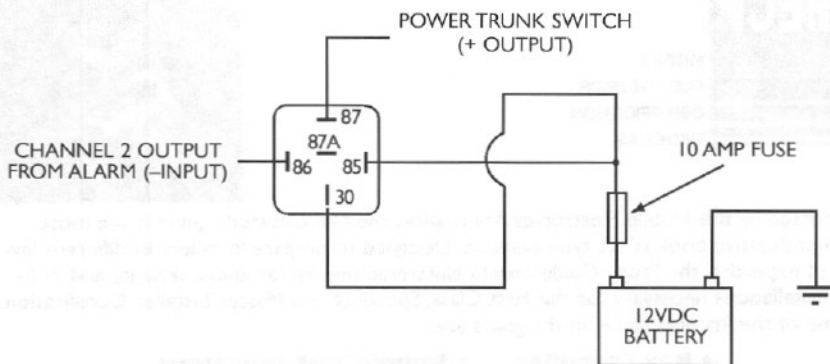

TRUNK RELEASE FOR THE 1994 CADILLAC SEDAN DE VILLE

The trunk release for the Sedan DeVille has changed for 1994. The switch is now a negative trigger and will only work with the ignition on. The wire is light blue and is located at the driver's kick panel. This schematic explains how to interface an alarm's auxiliary output to the trunk release.

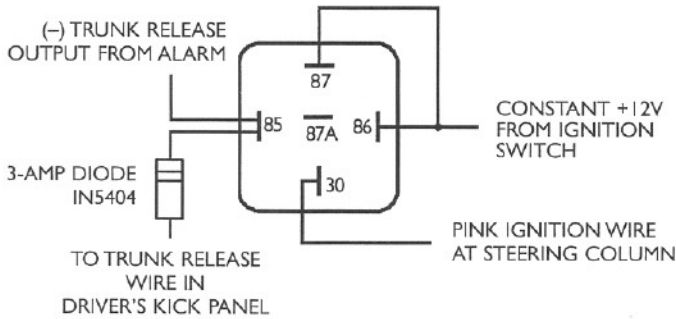

MECP STUDY GUIDE

MECP

MOBILE
ELECTRONICS
CERTIFICATION
PROGRAM

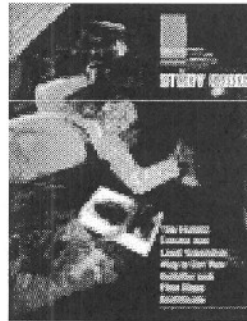

Endorsed by the Mobile Electronics Association, the M.E.C.P. study guide is the most comprehensive book of its type available. Designed to prepare installers of different levels of expertise, the Study Guide covers electronic theory, car audio, security and cellular installations necessary for the First Class, Specialist and Master Installer Certification. Some of the features found in the guide are:

- Key Formulas
- Margin Notes
- Illustrations
- Sample Test Questions
- Glossary

A great reference manual to have around.

Become a Certified Installer. Order Your Copy Today!



FREE PRODUCT CATALOG!

DLC is your First Source for Electronic Parts and Accessories with thousands of items to choose from in thirteen different categories. Our 63 page catalog is available absolutely free by filling out this form completely, and faxing or e-mailing it to the addresses shown below.

Last Name _____ First _____

Title _____ E-Mail: _____

Phone () _____ Fax () _____

Company _____

Business Address _____

City _____ State _____ Zip _____

Business Type (Check as many as apply)

- Distributor
 - Retailer
 - Sales
 - Service
 - Installation
 - Other
- Number of installers at your location? _____

Product Type (Check as many as apply)

- Autosound
 - Auto Security
 - Cellular
 - Two-Way
 - Other
- Would you like to receive our monthly fax specials? We offer monthly fax specials to those customers with a dedicated fax line.
 Yes No

No. of Locations

- 1
- 2-5
- 6+

**E-Mail your complete form to: sales@dlcparts.com or
Fax it to (800) 421-3538 Attention: Relay Guide**