

**PARTS LIST - TUNE-UP KIT
MODEL 71/92A (6V)
PART NUMBER 017056**

TUNE-UP KIT PARTS LIST

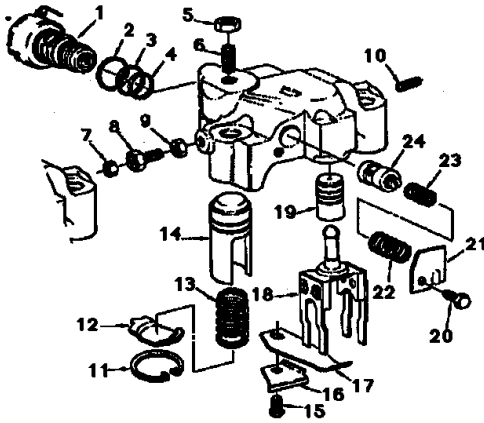

ILLUS.	PART NO.	PART NAME	QTY
2	001081	Seal Ring - Upper	2
3	001082	Seal Ring - Center	2
4	001083	Seal Ring - Lower	2
7	001332	Seal Ring	4
8	001287	Connector - Oil	4
9	001340	Nut - Hex Jam	4
10	001341	Set Screw	4
11	001023	Ring - Retaining	6
15	001265	Capscrew - Button Head	6
16	003669	Retainer Master Spring	6
17	009505	Spring Master Piston	6
20	001492	Capscrew - Hex Head	6
21	002221	Cover Control Valve	6
22	011434	Spring Stop Control Valve	6
23	007500	Spring - Control Valve	6
24	011930	Control Valve	6
25	002299	Terminal Assy.	2
27	015811	Wiring Harness Assy.	2
28	016467	Receptacle	4

The parts in this kit are the most recent design by Jacobs, for the Model 71/92A and are interchangeable with earlier production units. Follow the procedures outlined on this sheet. For complete information, refer to the Jacobs Engine Brake Installation Manual, Part No. 3879.

Remember! Always use the proper tools and proper procedures and wear safety glasses.

1. Thoroughly clean the engine.
2. Remove the valve rocker covers.
3. Disconnect electrical connection to engine brake.
4. Remove any clamps which hold wires to the engine brake housings. Discard all screws and wire clamps. They are no longer used.
5. Remove any additional wire clamps, connectors, and wiring in the cylinder head area.
6. Loosen all slave piston adjusting screw locknuts (5) and back out the adjusting screws (6) until the slave pistons (14) bottom in their bores.
7. Loosen the locknuts (9) on the oil connectors (8). Screw the oil connectors in until the rubber seals (7) can be removed.
8. Using a Jacobs solenoid valve wrench, P/N 011494, for earlier style solenoids or a 7/8 in. socket for current style solenoids, unscrew the solenoid valve assemblies (1) and remove them from their housings. Remove the two seal rings (2 & 3) from the solenoid valve body. Be sure to remove the third seal ring (4) from the bottom of the bore. Use a hooked wire if required. Place the valves on a clean surface.
9. Loosen and remove all of the brake housing hold-down bolts.
10. After marking the location of each brake housing assembly, remove the housings and place them on a clean work surface.
11. The exhaust valve bridges can be readjusted at this time. Engine adjustments should be made by trained technicians in accordance with information given in Detroit Diesel publications.
12. Although they are not included in this tune-up kit, it is recommended that you install new fuel pipes at this time. Lubricate all fuel pipe flare ends and hold-down nut threads with clean engine oil. Hand start and, while positioning the fuel pipe to find its seat, finger-tighten the fuel pipe nuts to insure proper engagement and to prevent cross-threading. You must use a fuel pipe wrench and torque wrench. Tighten the fuel pipe nuts to 10 lbft (13 N·m) torque. Loosen the nuts and retorque to 10 lbft (13 N·m).
13. Now turn your attention to the engine brake housings.
14. Remove and discard the rubber oil seal rings, oil connectors, locknuts, and set screws.

⚠ WARNING

THE CONTROL VALVE COVER PLATES HOLD SPRINGS UNDER PRESSURE, SO REMOVE THE COVER PLATES CAREFULLY TO AVOID PERSONAL INJURY.

15. Slowly remove the screws (20) that hold down the control valve cover plates (21) remove and discard the control valve springs (22 & 23). Using needle-nose pliers, grasp the stem of the control valve (24) and pull it out of its bore. Discard the control valve.
 16. Thoroughly clean the control valve bore in each housing, using clean paper towels. Never use rags, as they may leave lint and residue which can plug the oil passageways.
 17. Clean out the solenoid valve bore in the supply housing.
- NOTE: Supply housings contain solenoid valves. Do not hose housings do not.**
18. Apply clean lube oil to the control valves. Holding the valve by the stem, let the valve drop into its bore.
 19. Using new springs from the kit, insert the small diameter spring over the stem of the control valve. Insert the large diameter spring over the smaller spring. Reinstall the cover using new cap screws.
 20. Wash out the solenoid valve with an OSHA approved cleaning solvent. Use a brush to clean the oil screen. When clean, dry the valve with compressed air.
 21. Install a new seal ring in the base of the solenoid valve bore. Wipe clean lube oil into and around the bore. Install the upper and center seal rings onto the solenoid valve body. Now insert and screw down the solenoid valve assembly. Torque the valve to 60 lb in (7 N·m). Be careful not to twist the seals while installing.

⚠ WARNING

WEAR SAFETY GLASSES AND USE CAUTION WHEN REMOVING THE SLAVE PISTON COMPONENTS. THE SPRINGS ARE UNDER HEAVY COMPRESSION AND IF DISCHARGED CAN CAUSE PERSONAL INJURY IF PROPER PROCEDURES AND TOOLS ARE NOT USED.

22. Remove the slave piston spring retaining ring (11). Using Jacobs assembly fixture, P/N 012398, or an arbor press.
23. Compress the spring retainer (12) enough to remove the load from the retaining ring and using retaining ring pliers remove the retaining ring.
24. Remove the load from the spring retainer by slowly backing out the screw in the tool until the spring (13) is relaxed. Remove the retainer, spring, and slave piston (14).
25. Clean all parts and the slave piston bore in an OSHA approved cleaning solvent. Inspect all parts for wear or damage and replace as needed.

26. Use a new retaining ring and replace all the components reversing the removal procedure.
27. Remove the screws (15), retainers (16), flat springs (17), fork assemblies (18) and master pistons (19) from the housings. Discard the springs and screws.
28. Inspect the master piston and fork assembly for damage and excessive wear and replace, if necessary.
29. Reinstall the master piston components using new flat springs and screws from the kit.

NOTE: When tightening the screws on the flat springs be sure the spring is centered in the fork assembly.

30. In the appropriate housing counter bores, insert new lube oil seal rings.
31. In each of the remaining housing locations, install a new oil connector with a new locknut attached.
32. Lubricate the threaded section and beneath the head area of the hold-down bolts. Assemble the bolts to the brake housing and position each housing back over the cylinder from which it was removed. Align and level the housing. Position the master piston fork assembly over the injector push rod clevis. It should fit freely, easily, and with no binding.



MAKE CERTAIN THE FUEL PIPES DO NOT INTERFERE WITH THE ENGINE BRAKE HOUSING.

33. Torque the hold-down bolts to 90 lbf (120 N-m).
34. Reposition the seal rings to insure proper fit into the head of the oil connector.
35. Screw out the oil connectors until metal-to-metal contact is made with adjacent housing. Back off 1/3 turn from contact point to establish working clearance. Hold jumper in this position and lock locknut.
36. Adjust valves and time injectors as instructed in the engine tune-up section of the applicable Detroit Diesel service manual. Engine adjustments should be made by a trained technician.
37. Adjust slave pistons.
38. You must make slave piston adjustments with the engine stopped and cold. The exhaust valves on the cylinder to be adjusted must be in the closed position. Loosen the locknut and back off the slave piston adjusting screw on the cylinder with the exhaust valves closed. Back out the adjusting screw until the slave piston bottoms in the engine brake housing.



YOU MUST STRICTLY ADHERE TO THE FOLLOWING ADJUSTMENT PROCEDURE. ANY OTHER METHOD OF ADJUSTING THE SLAVE PISTON CLEARANCE IS NOT AUTHORIZED BY JACOBS AND MAY RESULT IN SERIOUS ENGINE AND/OR ENGINE BRAKE DAMAGE.

Housing marked Model 71 or 71/92 - .064" (1.6 mm)

Use Jacobs gauge, P/N 003496

Current Rocker Brackets and Housings marked Model 71A or 71/92A - .059" (1.49 mm)

Use Jacobs gauge, P/N 007958

Two valve engines Model 71/92 and 71/92A - .064" (1.6 mm)

Insert the correct feeler gage between the slave piston foot and the exhaust valve bridge. Turn the adjusting screw in until a slight drag is felt on the feeler gauge. Hold the adjusting screw in this position and tighten the locknut to 18 lbf (24 N-m) torque. Recheck for proper clearance.

WIRING DIAGRAM (6V ENGINES)

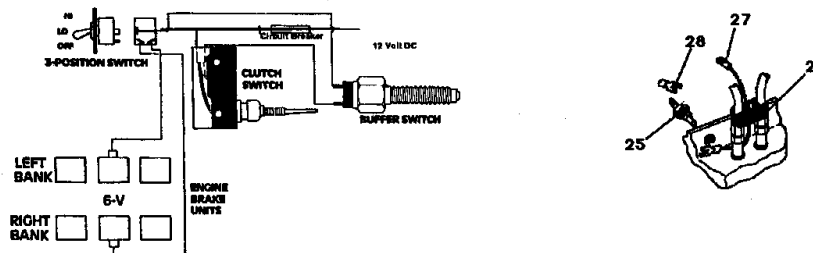

39. Remove the seal bushing, wire harness support (26) and solenoid lead wires. Cut the wire near seal bushing.
40. If the solenoid has push on type receptacles instead of screw on type, cut the connector off of the harness (27) and install a push on type receptacle (28).
41. Install the new wire harness support (26) (grooved rubber block), between the fuel pipes that are closest to the engine brake supply housings.
42. Install the terminal lead out assembly (25) in the threaded hole in the cylinder head rim. Use a 7/16 in. 6 point box wrench and tighten until seated.
43. Attach a receptacle (28) to the wire and connect to the terminal lead out assembly.
44. Connect the under cover harness to the solenoids and to the terminal lead out assembly.
45. Run engine with valve covers off and check for fuel leaks around fuel pipe connections.
46. Replace the valve rocker covers and any engine compartment parts.
47. To insure proper engine brake operation, check engine brake wiring and switch adjustments. Make corrections as required.

JACOBS ENGINE BRAKE REPLACEMENT PART LIMITED WARRANTY

Jacobs Engine Brake replacement parts, products of The Jacobs Manufacturing Company, are sold with the following warranty.

Jacobs Engine Brake replacement parts are warranted to be free of defects in construction and operation under normal use and service for the warranty coverage periods set forth below.

THERE ARE NO REPRESENTATIONS OR WARRANTIES WHICH EXTEND BEYOND THE TERMS HEREOF OR THE DESCRIPTION OF THE PRODUCT CONTAINED IN THE CONTRACT FOR SALE.

Warranty Coverage:

Replacement parts are warranted for 3 months or 24,000 miles (26,800 kilometers), whichever shall first occur. Replacement parts installed during the original warranty coverage period for a Jacobs engine brake are warranted as stated in the Jacobs engine brake warranty.

Under this warranty our factory is obligated to replace, without charge, any part returned to us which our examination discloses to our satisfaction to have been defective within the Warranty coverage period measured from the date of delivery of the product in question to the original user.

Jacobs will also pay for all repairs to damaged engine components in which Jacobs replacement parts have been properly installed, provided the damage is shown to be a direct result of a defect of Jacobs replacement parts occurring under normal operation during the warranty coverage periods specified above.

This warranty will not apply to any part or parts which have been altered or repaired outside of our factory or authorized Jacobs distributor service centers, nor to parts which have been subjected to misuse, abuse, neglect, or accident, nor to parts which have been improperly applied or installed. Improper installation or application, or substitution of parts not manufactured or approved by us, shall void this warranty.

JACOBS' SOLE LIABILITY AND YOUR EXCLUSIVE REMEDY IS LIMITED TO THE OBLIGATIONS SET FORTH HEREIN, AND JACOBS SHALL NOT BE LIABLE FOR ANY SPECIAL, INDIRECT OR CONSEQUENTIAL DAMAGES.