

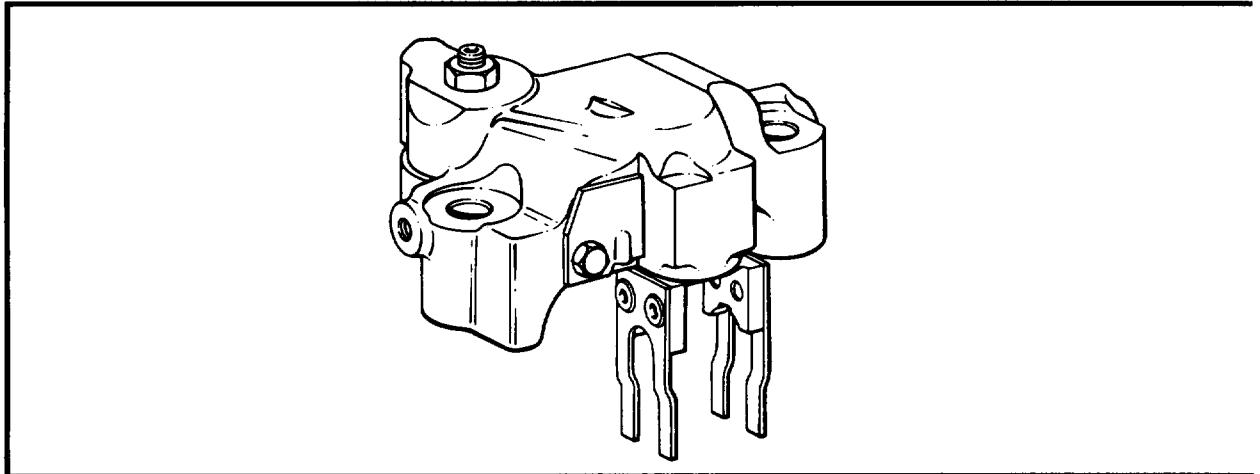

# Installation Manual for Models 71A and 92A Engine Brakes



The Models 71A and 92A are approved for use on all Detroit Diesel Corporation series 71 and 92 engines with 4 valve cylinder head configuration. Included in this manual are instructions for engine brake installations on engines equipped with Detroit Diesel Electronic Control (DDEC).

## **WARNING**

*See Jacobs Driver's Manual  
for proper engine brake  
driver techniques*

The **Jake Brake Retarder** is a vehicle slowing device, not a vehicle stopping device. It is not a substitute for the service braking system. The vehicle's service brakes must be used to bring the vehicle to a complete stop.

The information contained in this manual was current at the time of printing and is subject to change without notice or liability.

*J*, *Jacobs*, *Jake Brake* and *Auto-Lash* are registered trademarks of Jacobs Vehicle Equipment Company. *Jake* is a Marc. Reg. in Mexico. *Power-Lash*™ is a trademark of Jacobs Vehicle Equipment Company.

This product is covered by U.S. patent no. 4,251,051. Other U.S. and foreign patents issued or applied for.



**Jacobs**® Vehicle  
Equipment Company  
22 East Dudley Town Road  
Bloomfield, CT 06002 USA  
203-243-1441

# TABLE OF CONTENTS

SECTION 1	
INTRODUCTION .....	3
Housing Identification .....	3
Special Tools/Torque Values .....	3
Rocker Covers .....	3
SECTION 2	
ENGINE PREPARATION .....	4 - 7
Valve Bridge Adjustment .....	5
Fuel Pipe Installation .....	6, 7
SECTION 3	
BRAKE HOUSING INSTALLATION .....	7 - 10
Housing Installation .....	7, 8
Valve and Injector Adjustment .....	8, 9
Fuel Control Adjustment .....	9, 10
Slave Piston Adjustment .....	10
SECTION 4	
ELECTRICAL SYSTEM INSTALLATION .....	11 - 16
NON-DDEC Controls .....	11 - 13
DDEC Wiring Schematic .....	14
DDEC Controls .....	14 - 16
SECTION 5	
ENGINE BRAKE OPERATION CHECK .....	17
SECTION 6	
ENGINE BRAKE MAINTENANCE .....	17 - 21
Exploded View .....	18
Control Valve .....	18, 19
Solenoid Valve .....	19, 20
Slave Piston .....	20, 21
Master Piston .....	21

---

---

## SAFETY PRECAUTIONS

The following symbols in this manual signal potentially dangerous conditions to the mechanic or equipment. Read this manual carefully. Know when these conditions can exist. Then take necessary steps to protect personnel as well as equipment.



This symbol warns of possible personal injury.



This symbol refers to possible equipment damage.

### NOTE:

Indicates an operation, procedure or instruction that is important for correct service.

Fuels, electrical equipment, exhaust gases and moving engine parts present potential hazards that could result in personal injury. Take care when installing an engine brake. Always wear eye protection. Always use correct tools and proper procedures as outlined in this manual.

## SECTION 1 INTRODUCTION

### Housing Identification

The engine brake model number is cast into the top of each housing. The serial number is stamped on the flat surface near the slave piston adjusting screw. See Fig. 1. For all 71A/92A part numbers refer to the *Jacobs* parts manual, 15803.

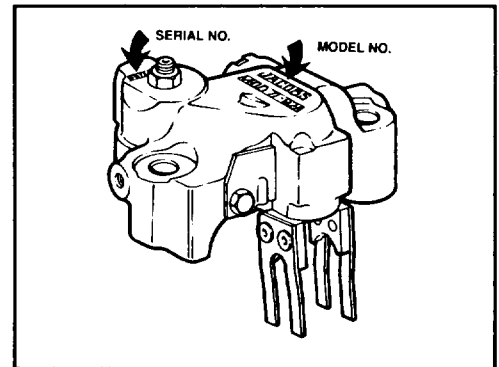

Fig. 1

### Special Tools

#### **Jacobs**

Feeler Gauge, 0.059 in. (1.50 mm)	P/N 7958
Feeler Gauge, 0.064 in. (1.63 mm)	3496

#### **Kent Moore**

Fuel Pipe Nut Wrench	P/N J-8932-01
----------------------	---------------

#### **DDC**

Service Manual Series 71 and Series 92.  
Injector Adjusting Tool  
Fuel Modulator Adjusting Tool

### Recommended Torque Values

Part Name	Torque
Exhaust Valve Bridge Adjusting Screw Locknut	22 lbft. (30 N•m)
Fuel Pipe Nuts ( <i>Jacobs</i> )	10 lbft. (13 N•m)
Fuel Pipe Nuts (DDEC)	140 lbin. (16 N•m)
Injector Clamp Bolt	22 lbft. (30 N•m)
Engine Brake Hold-down Bolt	90 lbft. (120 N•m)
Slave Piston Adjusting Screw Locknut	18 lbft. (24 N•m)
Rocker Cover Hold-down Bolts	20 lbft. (27 N•m)
Solenoid Valve	60 lbin. (7 N•m)

### Engine Rocker Covers

The Model 71A/92A engine brake installation requires the Detroit Diesel "high profile" rocker covers (Fig. 2 and 3). If the engine is not equipped with high profile rocker covers, they must be obtained from DDC distributors. The current series 71 and 92 engine production uses the cast aluminum covers.

#### **NOTE:**

The *Jacobs* spacer (shown on page 17) was designed for the former series 71 engine low profile steel cover and cannot be used with the aluminum cover.

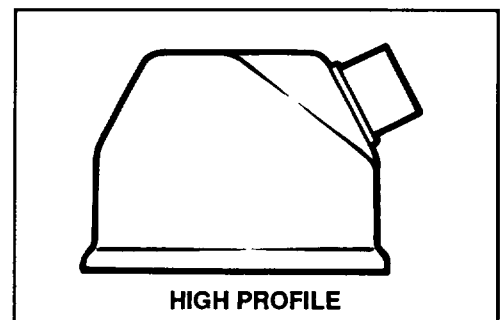

Fig. 2

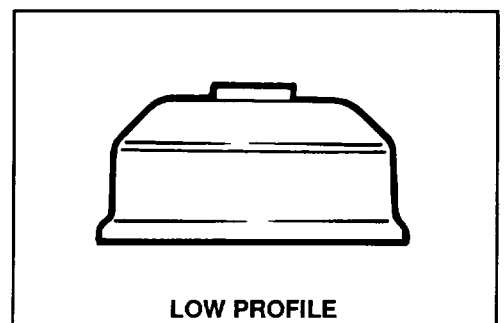

Fig. 3

## SECTION 2 ENGINE PREPARATION

The engine used for this installation manual is the 6V-92TA. Instructions for application to other Series 71 and 92 engines are covered in this manual.

Remove rocker covers.

Fig. 4

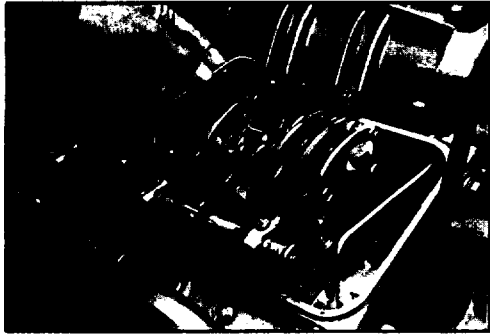

### Non DDEC Engines

Remove fuel supply and drain pipes. See Fig. 4. Discard fuel pipes.

### DDEC Engines

On engines with DDEC injectors, remove *and save* the injector fuel pipes. See Fig. 5.

Fig. 5

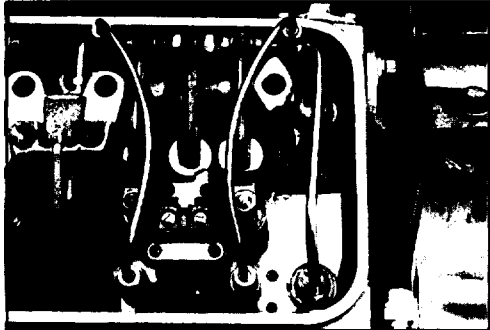

Remove the rocker bracket hold-down bolts (Fig. 6). Move the rocker shaft so that the right-hand exhaust valve bridge (viewed from fuel rack) can be removed.

Fig. 6

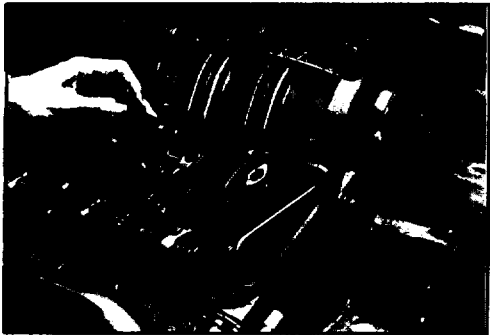

Remove adjusting screws from exhaust valve bridges and insert into the *Jacobs* bridges. See Fig. 7.

Fig. 7



### CAUTION

When loosening the locknut, hold bridge in vise. Do not loosen locknut while bridge is installed in engine. Valves may become bent, resulting in engine damage.

Install *Jacobs* exhaust valve bridges onto bridge guides for right-hand exhaust valves.

## Valve Bridge Adjustment

While pressing straight down on the pallet surface of the valve bridge, turn the adjusting screw clockwise until it just touches the valve stem (Fig. 8). Then turn the adjusting screw an additional 1/8 to 1/4 turn clockwise and tighten the locknut finger tight.



Fig. 8

Remove the bridge and place in a vise (or holding fixture as shown in Fig. 9). Hold the adjusting screw with a screwdriver and torque the locknut to 22 lbft. (30 N•m).



Fig. 9

Lubricate the valve bridge guide pin and install the bridge in its original position. Place a 0.0015 in. (0.038 mm) feeler gauge under each end of the valve bridge.

**NOTE:**

A narrow strip of 0.0015 in. feeler stock must be used under the locating groove over the inner exhaust valve. See Fig. 10.

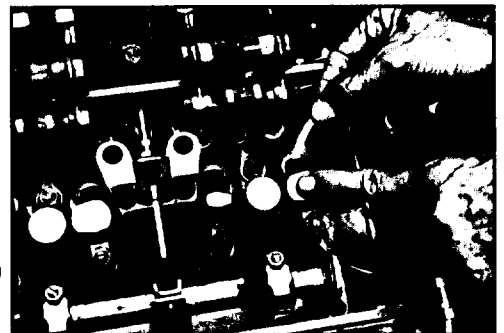

Fig. 10

While pressing down on the pallet surface of the bridge, both feeler gauges must be tight. If the gauges are not tight, readjust the bridge.

**NOTE:**

Older engines may have rocker arms having an oil drill boss. If boss is present, remove right hand rocker arm and grind off boss. See Fig. 11. This is done to provide clearance for the slave piston.

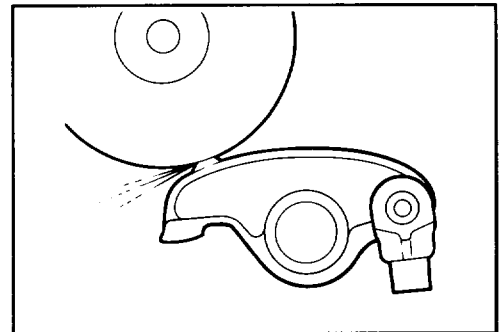

Fig. 11

**NOTE:**

It is necessary to remove injectors which have been operated in an engine before replacing filter caps.

## Fuel Pipe Installation

### Non DDEC Engines

Replace flare-style fuel pipes with O-ring style fuel pipes. In the following instructions, numbers in parantheses refer to Figs. 12a&b.

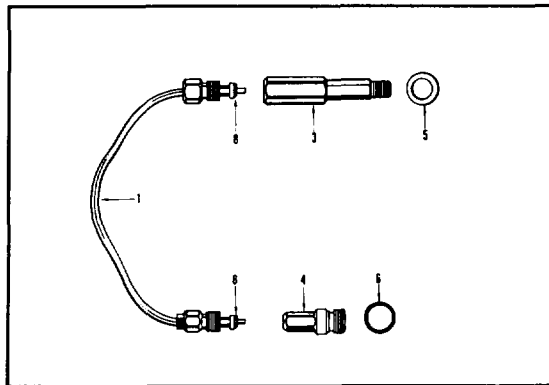

Fig. 12a

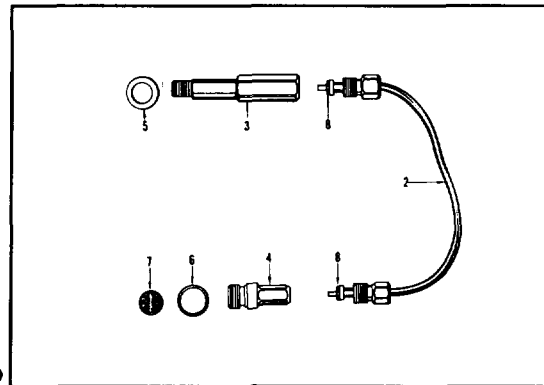

Fig. 12b

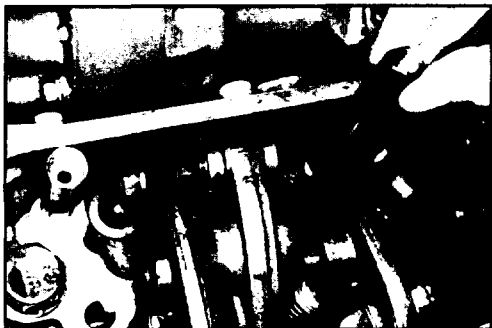

Fig. 13

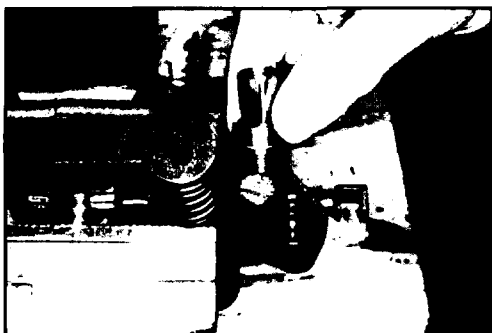

Fig. 14

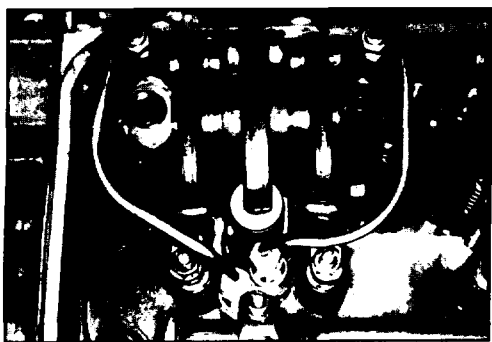

Fig. 15

1. Remove injectors according to instructions in the DDC engine service manual. Remove fuel connectors from cylinder head.
2. Install the new connectors (3) with washers (5) into the cylinder head (2 per cylinder). See Fig. 13. Torque the connectors to 40-45 lbft. (54-61 N•m).
3. Remove injector filter caps, washers, gaskets/ fuel inlet filters.
4. Install the new filter (7) into the inlet port of the injector, grooved side up. The injector inlet port is located above the control rack. See Fig. 14.
5. Install the new fuel injector caps (4) and gaskets (6) into the inlet and return ports of the injector. Torque the caps to 60-70 lbft. (82-95 N•m). Use a deep well socket and torque wrench.
6. Install and adjust the fuel injectors according to instructions in the DDC engine service manual.
7. Remove the protective caps from the fuel pipes.

**NOTE:**

The O-rings (8) must be installed on the fuel pipes.

8. Lubricate the O-rings with clean lube oil and install the short (inlet) (2) and long (return) (1) fuel pipes.



Set the pipe ends into the fittings. Hand-tighten the fuel pipe nuts. Do not bend fuel pipes. See Fig. 15. If the connections do not fit easily into the fittings or, if there is interference with the engine brake housing, replace the fuel pipes. Bending the fuel pipes may result in fuel leakage and severe engine damage.

9. Torque the fuel pipe nuts to 160-200 lbin. (18-23 N•m) using a fuel pipe nut socket and torque wrench.

## DDEC Engines

On engines equipped with DDEC injectors reinstall the original DDEC fuel pipes turning them 180 deg. from their original installed position. See Fig. 16. The bend in the fuel pipes must be aimed away from the injector.

Tighten the DDEC fuel pipe nuts to 160-200 lbin. (18-23 N•m).

Fig. 16

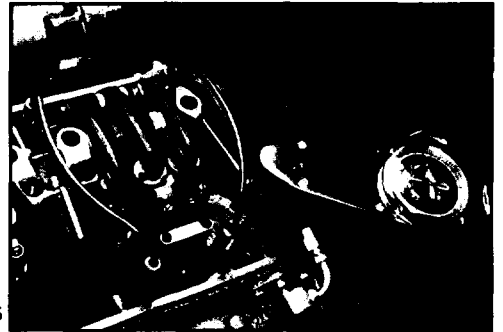

## SECTION 3 BRAKE HOUSING INSTALLATION

### Housing Installation

Prior to installing *Jake Brake* housings on the engine, the housings should be laid out on a work bench in the order shown in Figs. 17a or 17b to match engine configuration. The oil jumper screws, seal rings and end plugs should be installed as indicated.

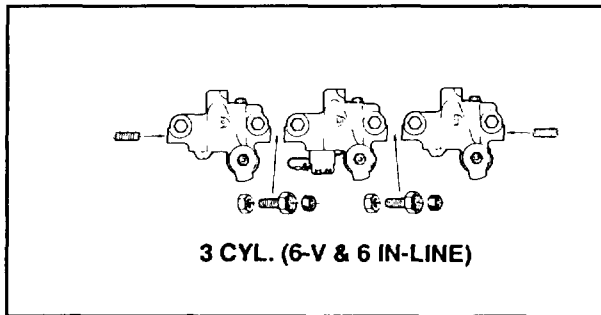

Fig. 17a

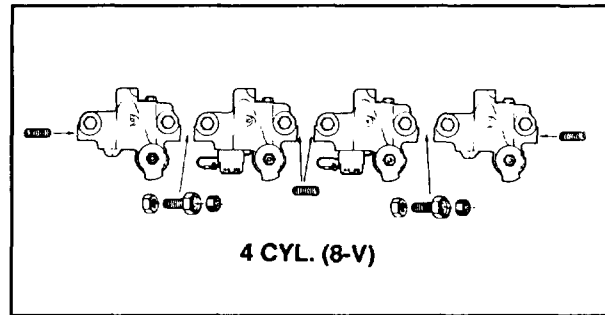

Fig. 17b

Insert oil jumper with locknut into housing. See Fig. 18. Turn in approximately 1/2 in. (13 mm) to avoid damage during assembly on the engine.

Fig. 18



Insert and tighten 1/4-28 plugs on outboard side of end brake units. See Fig. 19.

Fig. 19



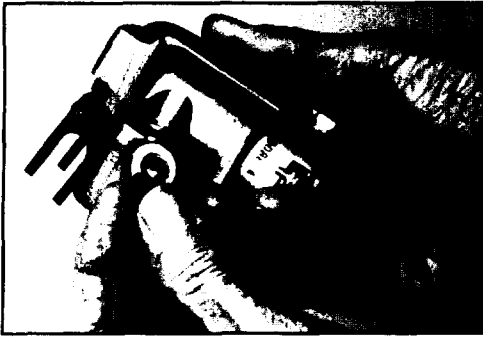

Insert lube seal ring into counterbore (Fig. 20).

Fig. 20

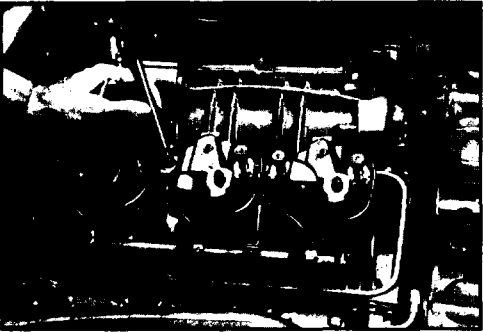

Fig. 21

Assemble *Jacobs* hold-down cap screws to brake housing (Fig. 21). Position housing over rocker assembly checking that the master piston fork guide is properly located over the injector push rod clevis.

Torque hold-down bolts to 90 lbf. (120 N•m).

**CAUTION**

Make certain that fuel pipes do not interfere with the engine brake housing. A fuel pipe rubbing on the engine brake housing will cause failure of the fuel pipe; subsequent engine damage may result. Loosen and reposition housings, if necessary, to clear fuel pipe. **DO NOT BEND FUEL PIPES**, as this will cause the pipes to leak resulting in subsequent engine damage.



Fig. 22

Reposition housings, if necessary, to ensure proper fit of the seal ring into the oil jumper screw. Back out the oil jumper screw until contact is made with adjacent housing. Then back off the screw 1/3 turn from contact point to establish working clearance. Hold screw in this position and tighten the locknut (Fig. 22).

**CAUTION**

Be sure jumper screw is backed out to provide working clearance. If the screw is allowed to contact adjacent housing during brake operation, the screw will break resulting in oil leakage and loss of engine braking.

## Valve and Injector Adjustment

The following are general adjustment procedures for setting the exhaust valves, injectors and fuel modulator. To obtain specific settings and tools required, consult the DDC service publications and the engine data plate located on the rocker cover. These adjustments will vary according to the specific engine and injectors used.

### Injector Adjustment

1. Place the governor stop lever in the stop position.
2. Rotate the engine until the exhaust valves are fully depressed for the cylinder to be adjusted.

**CAUTION**

If the crankshaft bolt is used to turn the crankshaft, do not turn in a left-hand direction of rotation or the bolt may loosen.



3. Place the injector timing gauge in the hole provided in the top of the injector body with the flat of the gauge toward the injector follower. See Fig. 23.

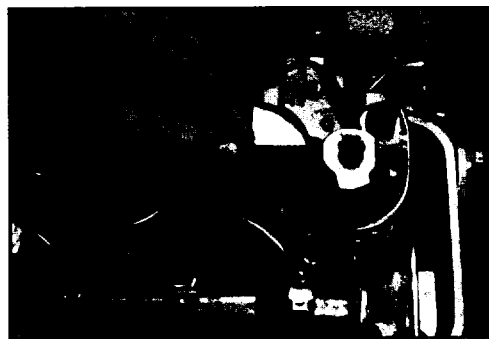

Fig. 23

The flat of the injector gauge should just pass over the top of the injector follower. If it does not, loosen the pushrod locknut and turn the pushrod to obtain the proper clearance.

4. Hold the pushrod and tighten the locknut. See Fig. 24.

Adjust the remaining injectors in the same manner as outlined above. Follow the firing order for the specific engine being adjusted.



Fig. 24

## Exhaust Valve Adjustment

Place the governor stop lever in the stop position. Rotate the crankshaft until the **injector follower is fully depressed** on the cylinder to be adjusted. Loosen the exhaust valve rocker arm push rod locknut.

Place a 0.016 in. (0.41 mm) feeler gauge between the valve bridge and the valve rocker arm pallet. Adjust the pushrod to obtain a slight drag on the feeler gauge. See Fig. 25.

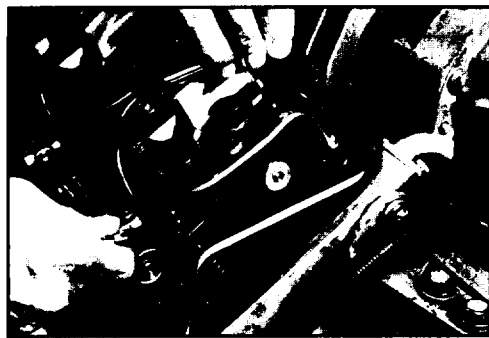

Fig. 25

Remove the feeler gauge. Hold the push rod with a 5/16 in. wrench and tighten the locknut with a 1/2 in. wrench. See Fig. 26.

Recheck the clearance. If the adjustment is correct, a 0.015 in. (0.38 mm) gauge will pass freely between the valve bridge and rocker arm pallet. A 0.017 in. (0.43 mm) gauge will not pass through. Readjust the pushrod, if necessary.



Fig. 26

## Fuel Control Adjustments

DDC uses a variety of fuel control devices that may require adjustment after engine brake installation. Following is a partial list of these devices:

1. Fuel Modulator
2. Throttle Delay
3. Power Control Device
4. Engine Load Limiting Device

### NOTE:

Each system requires a different adjustment procedure and special tools and gauges. It is recommended that DDC service manuals and topics be consulted for specific instructions regarding the fuel control system in question.



Fig. 27

## Fuel Modulator Adjustment

Before the fuel injector rack control levers are adjusted, the fuel modulator lever and roller assembly must be positioned free of cam contact. This is done by loosening the clamp screw. See Fig. 27.

After the injector rack control levers have been properly positioned, adjust the modulator, as follows:

1. With the engine stopped, insert the proper rack gauge between the injector body and the shoulder of the injector rack on the No. 2 cylinder (8V engines) or No. 1 cylinder (6V engines).
2. Position the governor speed control lever in the maximum speed position and the governor run-stop lever in the run position.
3. Rotate the modulator lever assembly and clamp on the injector control tube until the lever roller contacts the modulator cam with sufficient force to take up the pin clearance. Be sure that only the roller contacts the cam and not the lever stamping. Tighten the modulator lever and clamp screw. Check the setting by pushing on the cam directly over the roll pin. If the gauge is tight initially and loosens when the cam is pushed, the setting is correct.
4. Remove the gauge.

## Slave Piston Adjustment

### CAUTION

To prevent engine damage by piston to valve contact, the following instructions must be followed carefully. Prior to making slave piston adjustments, check that exhaust valves are closed and injector is in delivery position.

Slave piston clearance *must* be set according to type of housing and rocker brackets. See Fig. 28. Refer to the following chart:

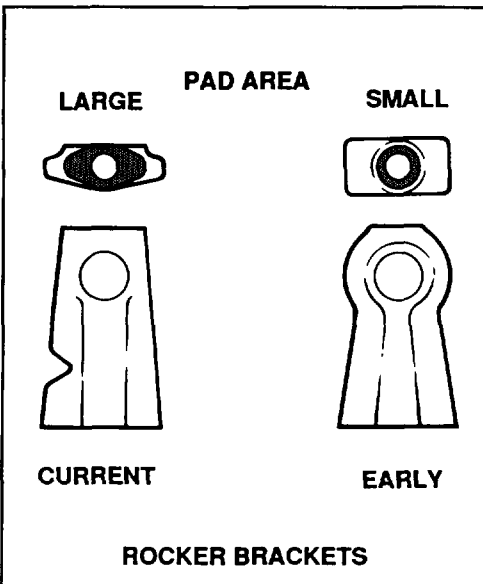

Fig. 28

### Housing/Bracket Type

Rocker Brackets with large pad area and 71A/92A Engine Brake Housings

### Slave Piston Setting

0.059 in.

All other combinations of brackets and housings 0.064 in



Fig. 29

With engine stopped and exhaust valves closed, insert the proper feeler gauge between slave piston foot and exhaust valve bridge. Turn adjusting screw in until a slight drag is felt on feeler gauge. Check both feet of slave piston and establish the setting under foot with minimum clearance. Hold adjusting screw in this position and torque locknut to 18 lbft. (24 N·m).

## SECTION 4 ELECTRICAL SYSTEM INSTALLATION

### Non-DDEC Controls

#### Buffer Switch Installation

**NOTE:**

There are two buffer switches available for 71-92 series engines. One for "V" configurations and one for In-line. See Fig. 30.

1. Remove the buffer screw assembly from the governor housing. See Fig. 30.
2. Remove the buffer screw locknut and install onto the *Jacobs* buffer switch.
3. Install the buffer switch into the governor housing about 1 turn. See Fig. 31.

**NOTE:**  
The buffer switch is not required for DDEC equipped engines.

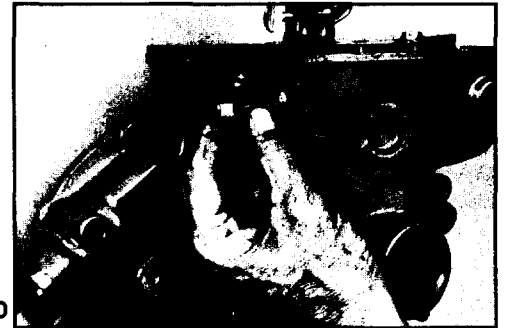

Fig. 30

4. Start the engine and allow to warm up. Record the idle RPM and maximum no load RPM. See Fig. 32a.



Fig. 31

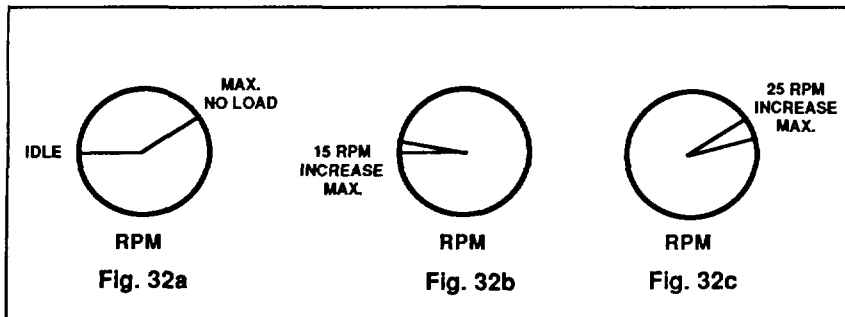

Fig. 33



5. With the idle speed set, adjust the buffer switch as follows:
  - a. Turn the buffer switch in until it contacts the connecting link as lightly as possible and eliminates engine roll (Fig 33).

**NOTE:**

Engine idle speed with the buffer switch must not increase more than 15 RPM from the reading recorded in step 4. See Fig. 32b.

- b. Hold switch in this position and tighten locknut (Fig. 34).
  - c. Check maximum no load speed. See Fig. 32c. If the increase is more than 25 RPM from the reading recorded in step 4, back off buffer switch until increase is less than 25 RPM.
6. Shut down engine.



Do not tighten locknut more than 60 lbin. (7 N·m). Switch failure will result from over-torquing.



Fig. 34

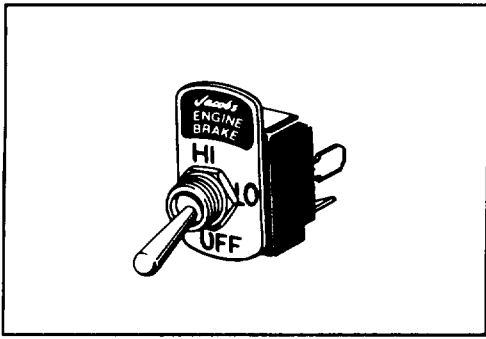

Fig. 35

### Dash Switch

Install the dash switch in a convenient location in the cab. Carefully measure and cut all harnesses to proper length. Thread wires through the loom provided. Install receptacles at locations shown in wiring diagram furnished in the kit.

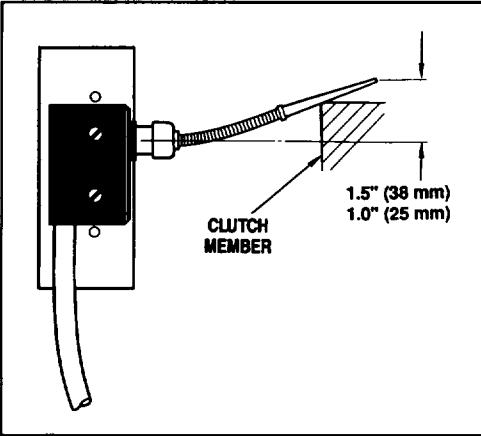

Fig. 36

### Clutch Switch

1. Mount the clutch switch in the most convenient or accessible location possible. Locations may include in cab under dash, under floor wheel well location, or in the area of the bell housing.
2. Install this switch with the switch actuator arm in contact with the clutch pedal arm or other clutch member.
3. Adjust the switch by moving the switch along the mounting bracket. The actuator arm should be deflected 1.0 - 1.5 in. (25 - 38 mm), measured at the tip of the actuator, when the clutch pedal is in the up (clutch engaged) position. See Fig. 36.
4. Check installation by moving the clutch pedal. The switch should click in the freeplay motion of the clutch pedal before actual clutch disengagement takes place.
5. Cut wires to proper length and secure them with ties. Connect the wires; black lead goes to power source.

The optional overtravel bracket should be used when the clutch switch is installed in the wheel well location or a location where a build up of road contamination (ice, mud, etc.) can stick to the actuator arm.

For vehicles with automatic transmissions, refer to Jacobs service letters or contact your nearest distributor.

## Solenoid Harness

1. Remove the plugs from the cylinder head locations as shown in Fig. 37.
2. Install the rubber wire supports to the fuel lines as shown.

**NOTE:**  
On in-line six cylinder heads, use two harness assemblies similar to the three cylinder head.

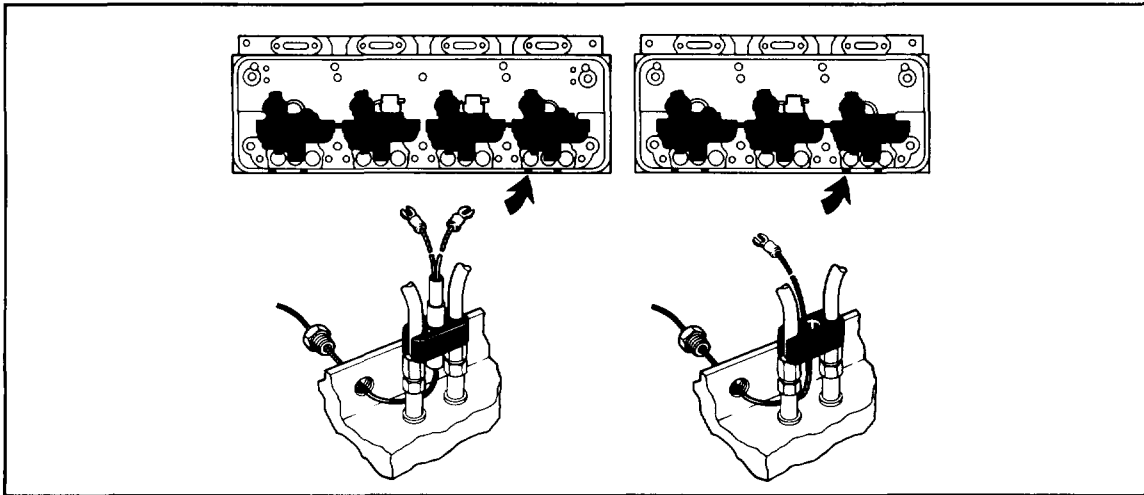

Fig. 37

3. Connect the terminals to the solenoid valves.
4. Pass the harness through the cylinder head access holes and install the terminal bushing.
5. Pull wire to take up slack between bushing and solenoid valve. Tighten bushing using a 7/16 in. six-point box end wrench. When tight, the bushing will squeeze the wire and effect a seal to prevent oil leakage. See Fig. 38.

- 6a. Early style buffer switches are polarity sensitive. Attach **NEGATIVE** lead (load side) to tin-plated terminal and the **POSITIVE** lead (power side) to the brass-colored terminal of the switch.

Fig. 38



- 6b. Current style buffer switches include a two diode system for switch protection. The two diode type switch is not polarity sensitive and electrical connections can be made to either terminal. See Fig. 39.

Fig. 39

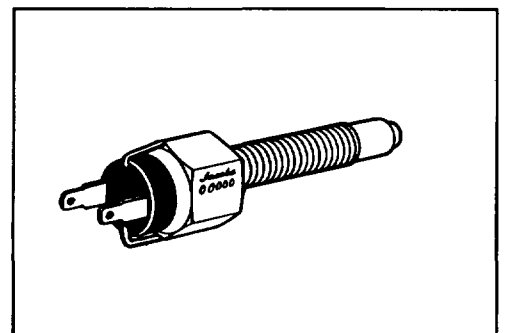

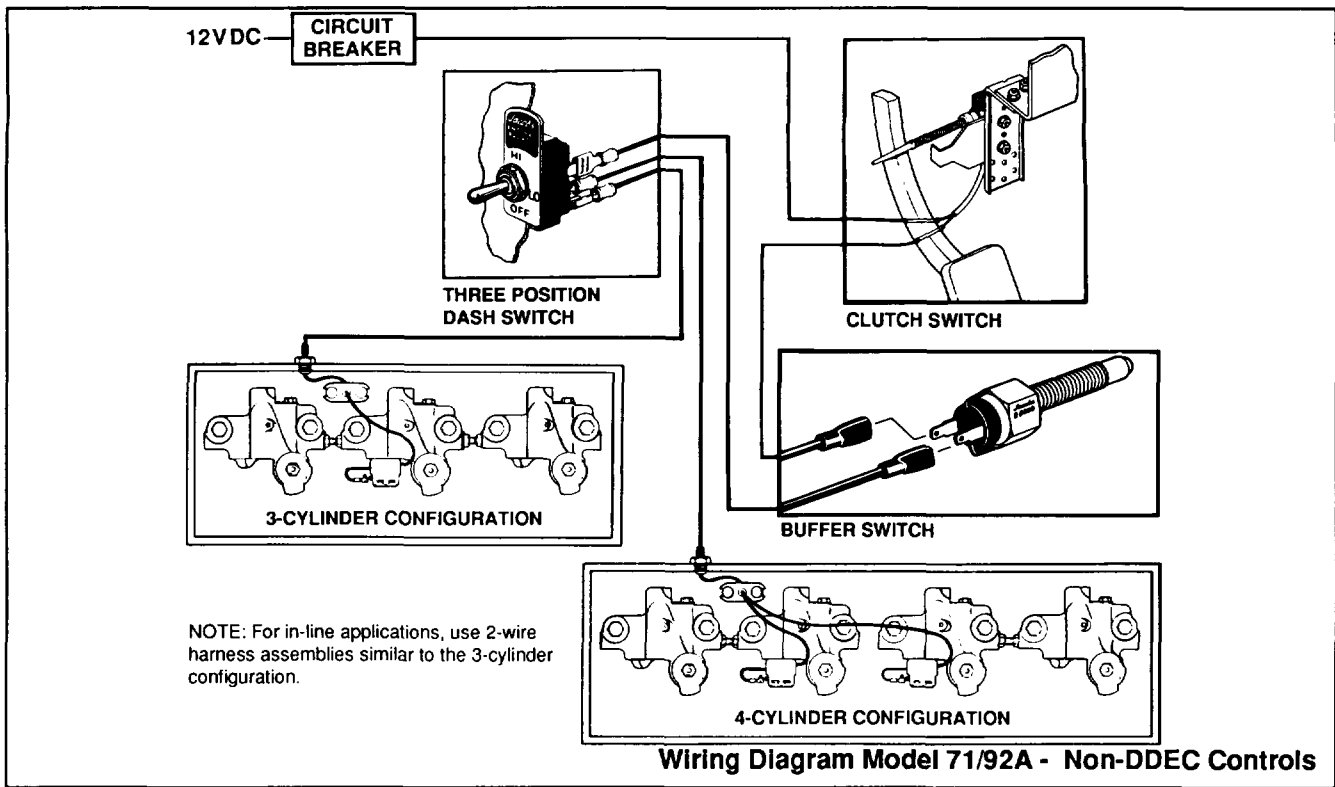

Fig. 40

## DDEC Controls

### Dash Switch Assembly

1. Locate an area on the dash for the dash switch assembly and drill a 2 in. hole.
2. Pass the loose wires of the in-line wire harness, P/N 17370, through the 2 in. hole from the back to the front.
3. Attach the flag connectors to the switches as shown in the wiring diagram. Be sure to follow the color code on the wires.
4. Install the switch assembly with the bracket, lock washers and wing nuts.

Fig. 41

### Alternate Dash Switch Mounting

Drill two 1/2 in. holes using the switch plate as a template. Mount the two dash switches with the faceplate and nuts. The groove in the switch threads must face down.

### Control Module

Mount the control module inside the cab. Mount the module using two self-tapping screws.

**NOTE:**

Mounting screws are not included in the kit.

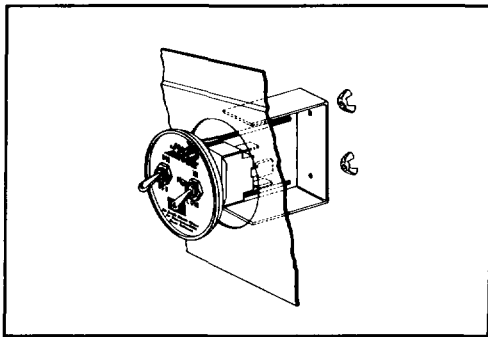

**CAUTION**

Do not overtighten nuts. Switch failure will result.

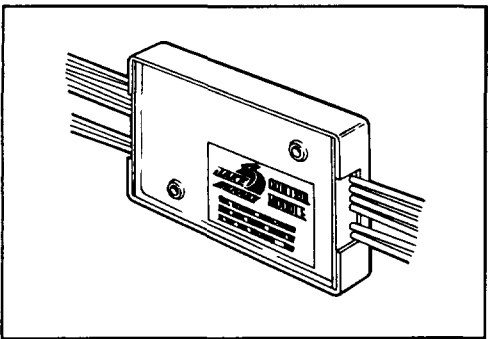

**CAUTION**

Do not allow control module to be unmounted or tie-wrapped behind the dash. Control module will be stressed and failure will result.

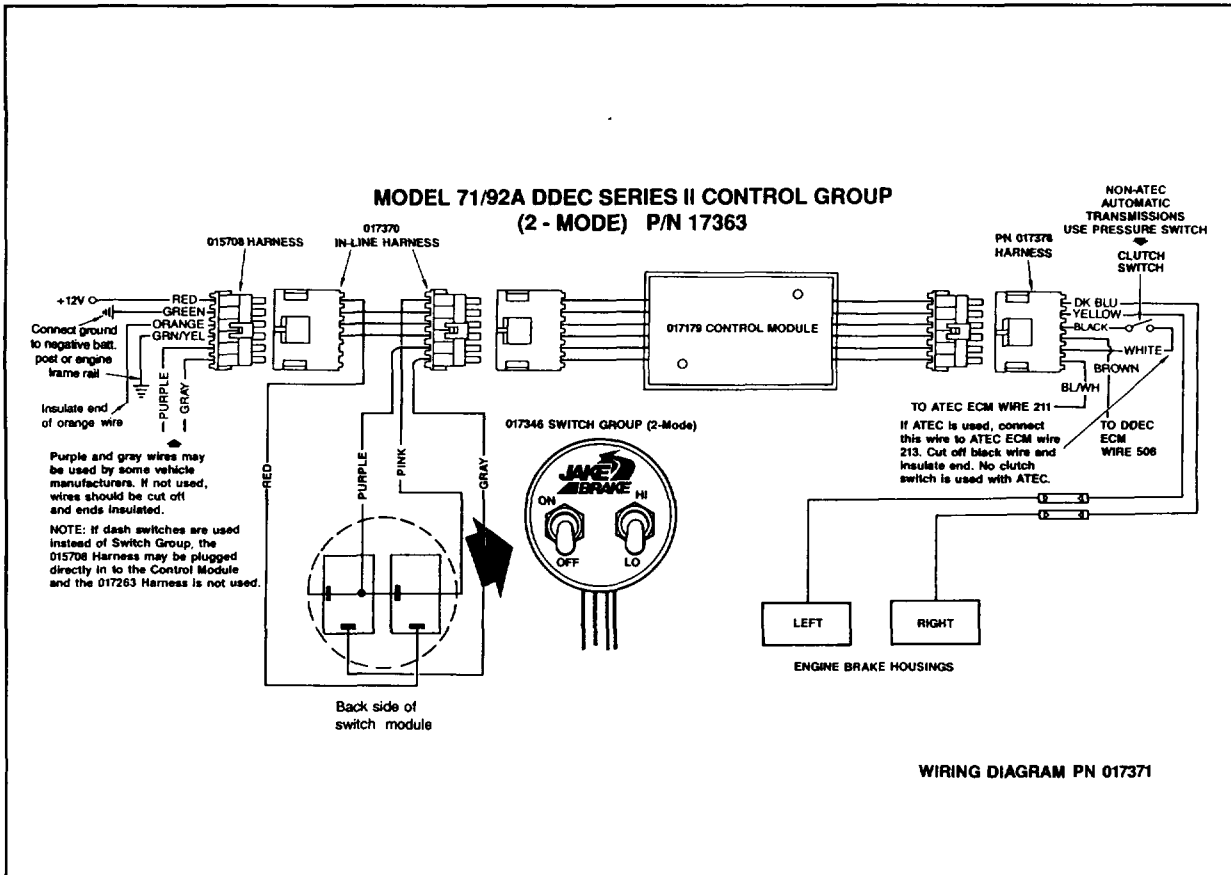

Fig. 43

Refer to the above wiring diagram for the following electrical connections:

**Wire Harness, P/N 15708**

1. Connect the wire harness, P/N 15708, to the Weatherpack<sup>®</sup> connector on the in-line harness, P/N 17370. Connect the other side of the in-line harness to the Weatherpack<sup>®</sup> connector on the control module.
2. Connect the **GREEN** wire to the negative (-) battery terminal.
3. Connect the **RED** wire to a 10 amp circuit breaker that is controlled by the key switch.
4. The **ORANGE** wire is provided for use on future electronic equipment. For current applications insulate the end and store the wire.
5. Connect the **GREEN/YELLOW** wire to the negative battery post.
6. If the optional dash switches are used in place of the *Jacobs* dash switch assembly, connect the purple and gray wires as shown in the wiring diagram for "optional dash switches."

**! WARNING**

It is very important that the **GREEN** wire be connected to a **GOOD GROUND**, such as the negative battery post or engine frame rail. Proper operation of the *Jake Brake* engine retarder electrical control system is dependent on securing a good ground connection. The green wire must be attached to the negative (-) battery terminal. Do not use body bolts or screws on the dash. A poor ground will cause intermittent engine brake operation and damage to the control module.

### Harness, P/N 17378

1. Connect harness, P/N 17378, to the control module.
2. **BLUE/WHITE** wire - For installations with standard transmissions, insulate the end and store the wire. If an automatic transmission is used, connect the blue/white wire to the ATEC wire number 211.
3. Connect the brown wire to the DDEC ECM wire number 508.
4. The white wire and black wire are connected to the clutch switch.
5. The dark blue wire and yellow wire are connected with butt splices to the harness that goes through the cylinder heads to the solenoid valves. See Fig. 43.

#### NOTE:

For Allison Electronic Transmission applications (ATEC) check that the blue/white wire on wire harness 17378 is connected to ATEC ECM wire No. 211.

For non-electronic Allison automatic transmission applications, a pressure switch must be used to sense lock-up in the transmission. The pressure switch takes the place of the clutch switch. The black wire and white wire should be connected to the pressure switch to sense transmission lockup.

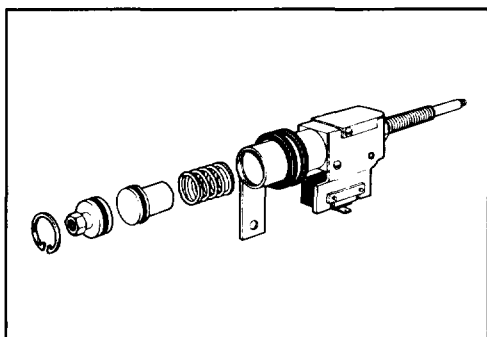

Fig. 44

### Optional Fast Idle Buffer Switch Installation (NON DDEC Engines)

A fast idle buffer switch may be purchased for buffer switch installations on Series 71 and 92 DDC engines containing fast idle air cylinders. This type switch must be installed to retain the fast idle feature in conjunction with automatic engine brake operation.

Disconnect air supply hose to fast idle cylinder. Remove and disassemble fast idle air cylinder. See Fig. 44.

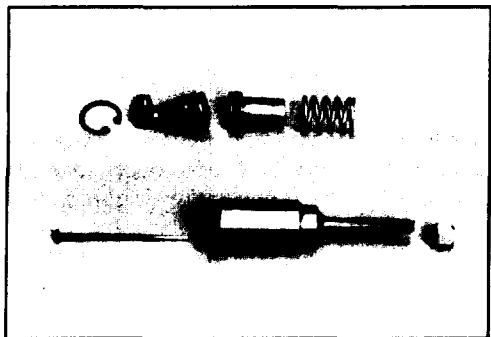

Fig. 45

Install cylinder spring, piston, inlet plug, retainer ring and locknut from fast idle air cylinder into *Jacobs* fast idle buffer switch assembly. Insert them in the order shown in Fig. 45. Separate buffer screw portion from fast idle buffer switch and install in governor housing. Adjust buffer screw following instructions beginning on page 11. Attach cylinder assembly to buffer screw and tighten locknut.

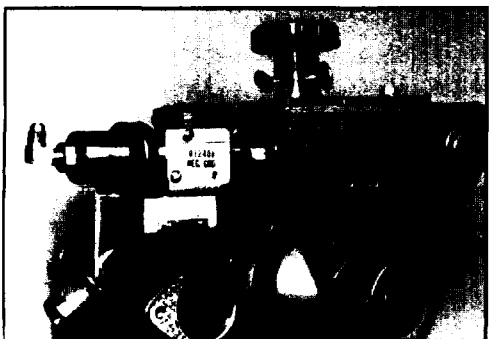

Fig. 46

Adjust switch bracket and clamp to line up with Detroit Diesel housing to blower bolt as shown in Fig. 46. Remove bolt and washer and secure switch by placing mounting bracket between washer and bolt. Tighten bolt and clamp. Install air supply hose to the fitting in cylinder. With the fast idle buffer switch properly installed the engine brake will operate only during deceleration and will automatically shut off when fast idle activation occurs.



---

## SECTION 5 ENGINE BRAKE OPERATION CHECK

Install rocker cover and gasket. See page 3 for information on appropriate engine cover to use when installing a *Jacobs* engine brake.

For low profile steel covers (model 71A), *Jacobs* spacers and cover extension screws may be used to raise the cover for engine brake clearance. See Fig. 47. The *Jacobs* spacer cannot be used with the low profile aluminum cover.

Torque cover hold-down bolts to 20 lbft. (27 N•m).

Check for fuel system leaks. See Caution.



Fig. 47

### CAUTION

Always check the fuel systems for leaks after injector or fuel pipe replacement and any time the fuel connections under the rocker cover are suspected of leaking. Failure to correct a serious fuel leak in this area can lead to dilution of the lube oil and bearing and/or cylinder kit damage.

After operating the engine for 20 - 30 min., shut it off and remove the rocker covers. Inspect the lube oil puddles that normally form where the fuel connectors join the cylinder head and where the fuel pipes join the fuel pipe nuts.

If there is any leakage at these connections, the lube oil puddles will be smaller or thinner than the puddles on the connectors that are not leaking. Disassemble, inspect, and correct or replace the suspect part (connector, injector or jumper line). Test and re-inspect.

---

## SECTION 6 ENGINE BRAKE MAINTENANCE

The *Jacobs* Engine Brake is typically a trouble-free and maintenance-free device. However, inspections are necessary and some maintenance is required. Use the following procedures to keep the engine brake in top condition.

This section will cover how to properly remove, clean and reinstall engine brake components. Use an OSHA-approved cleaning solvent when washing parts. Be sure to coat parts with clean engine oil when reinstalling them.

### WARNING

Never remove any engine brake component with engine running. Personal injury may result.

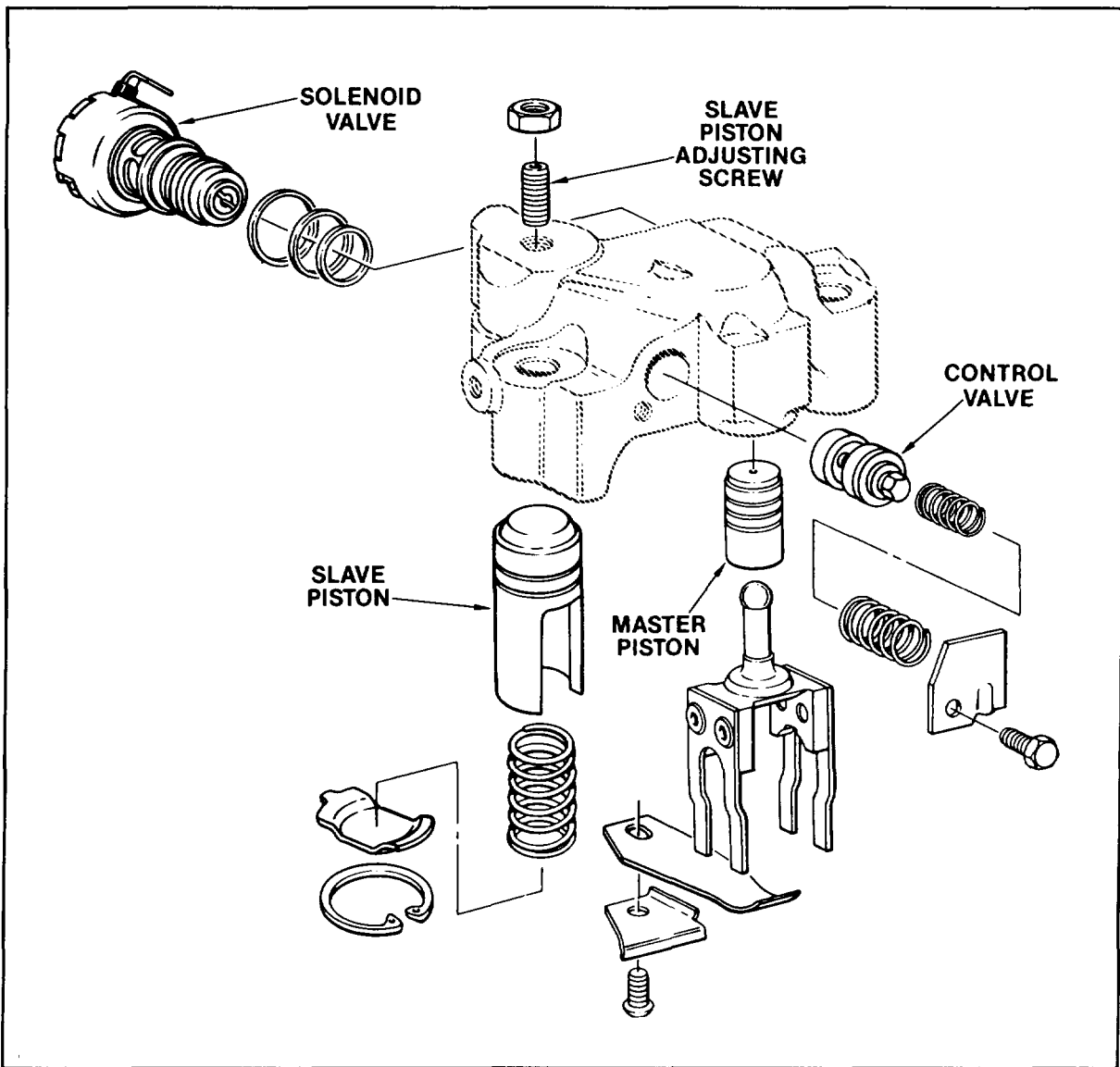

Fig. 48

## HOUSING ASSEMBLY EXPLODED VIEW MODELS 71A AND 92A

### Control Valve



Fig. 49

1. Apply pressure to the control valve cover and carefully remove the control valve cover capscrew. See Fig. 49.

#### **WARNING**

Remove control valve covers carefully. Control valve covers are under load from the control valve springs. Remove with care to avoid personal injury.

2. Slowly remove cover until spring pressure ceases, then remove the two control valve springs. See Fig. 50.

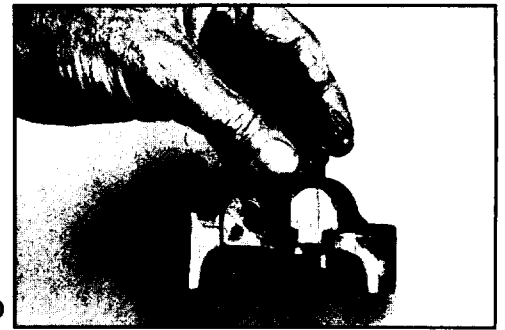

Fig. 50

3. Using needle-nose pliers remove the control valve (Fig. 51).
4. Wash the control valves with approved cleaning solvent. Push a wire through the hole in the base of the valve to the distance required to ensure that the ball check is free. The ball should lift with light pressure on the wire. Dry the valve with compressed air and wipe clean with a paper towel.

Thoroughly clean the control valve bore in the housing, using clean paper towels.

Dip the control valves in clean lube oil. Holding the valve by the stem, let the valve drop into its bore. If binding occurs or if the ball is stuck in the valve, the control valve should be replaced.

Reassemble parts reversing removal procedure.

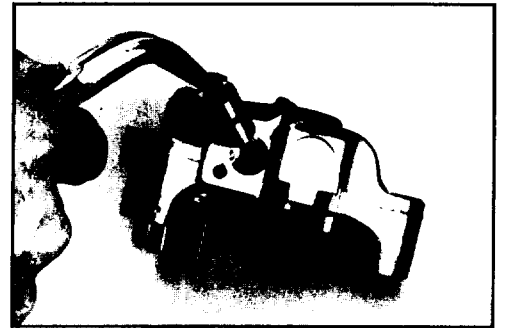

Fig. 51

## Solenoid Valve

1. Disconnect solenoid harness. Using 7/8 in. socket and extension, unscrew solenoid valve.

**NOTE:**

Early model solenoid valves require a *Jacobs* solenoid wrench.

2. Remove and discard the three rubber seal rings. If the lower ring stays in the bottom of housing solenoid bore, remove with a piece of wire.
3. Wash out the solenoid valve with approved cleaning solvent. Use a brush to clean the oil screen. When clean, dry the valve with compressed air.

Clean out the solenoid valve bore in the housing. Use clean paper towels. Never use rags, as they may leave lint and residue which can plug the oil passageways.



Do not disassemble or tamper with the solenoid valve. Engine damage could result.

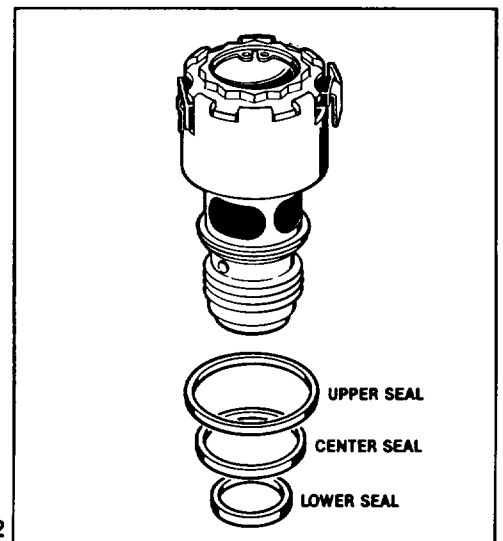

Fig. 52

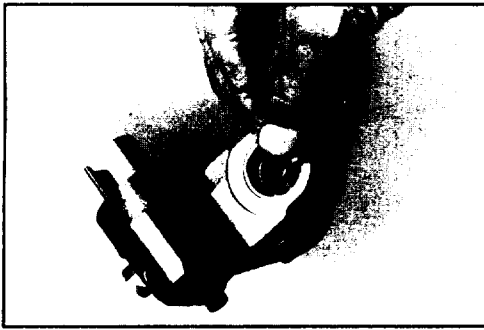

Fig. 53

4. Using new solenoid seal rings, coat them with clean lube oil (Fig. 53). Install the upper and center seal ring on the solenoid body and the lower seal ring into the bottom of the solenoid bore in the housing.
5. Be sure the seals are seated properly and carefully screw the solenoid into housing without unseating the seals. Torque the valve to 60 lbin. (7 N•m). Be careful not to twist the seals while installing.

**WARNING**

Wear safety glasses.

Remove slave piston carefully. The slave piston is retained by springs that are under heavy compression. If the following instructions are not followed and proper tools not used, the spring could be discharged with enough force to cause personal injury.

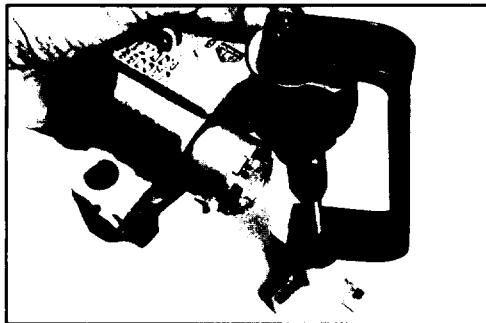

Fig. 54

Remove the locknut on the slave piston adjusting screw. Back out the adjusting screw until the slave piston is fully retracted (screw is loose).

Use slave piston clamp fixture and the following procedure to remove and replace the slave piston:

1. Place the hole in the clamp fixture over the slave piston adjusting screw. Replace locknut. Snug tighten to hold fixture securely. See Fig. 54.
2. While holding the fixture in position, screw the holder down over the slave piston until the retainer is contacted.
3. Turn the handle slowly until the retainer is depressed about 0.040 in. (1 mm) relieving pressure against the retaining ring. See Fig. 55.
4. Remove the retaining ring. Use retaining ring pliers. Back out the holder until the springs are loose. Remove the fixture.
5. Remove all components checking that there is no binding or burrs (Figs. 56a and 56b). Clean in an approved cleaning solvent, or replace as necessary.



Fig. 55



Fig. 56a



Fig. 56b

6. Use clamp fixture to reinstall piston and spring. Be sure retaining ring is placed on the retainer before screwing the clamp holder down over the slave piston.
7. Compress the slave piston and spring down until the retainer is about 0.040 in. (1 mm) below the retaining ring groove. Reinstall the retaining ring. Be sure the retaining ring is fully seated in the groove.

Rotate retaining ring 90 deg. in either direction.

Remove the clamp fixture slowly to ensure proper seating of retaining ring.

## Master Piston

Remove button head screw, lock plate and master piston spring from housing. See Fig. 57.

Remove fork assembly and master piston. See Fig. 58. Reassemble components reversing above procedure.

**NOTE:**  
Be sure all components are reassembled in proper order.



Do not leave the opening of the retaining ring aligned with the opening in the housing, as this will allow the spring retainer to become loose when the engine brake is operating. Serious engine damage will result.

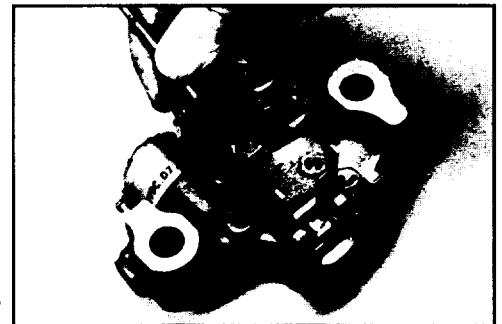

Fig. 57



Fig. 58

