

FMM #4A

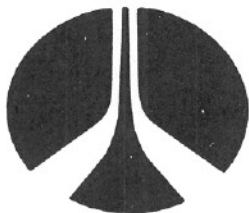

Rockwell "Q"™ SERIES
CAM-MASTER® BRAKES

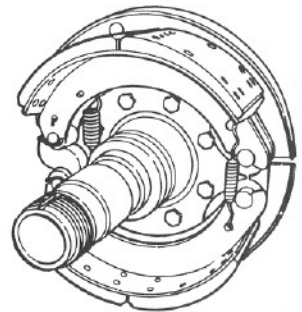
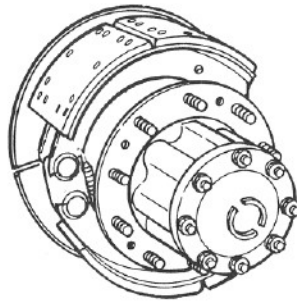
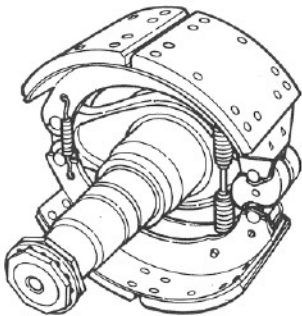
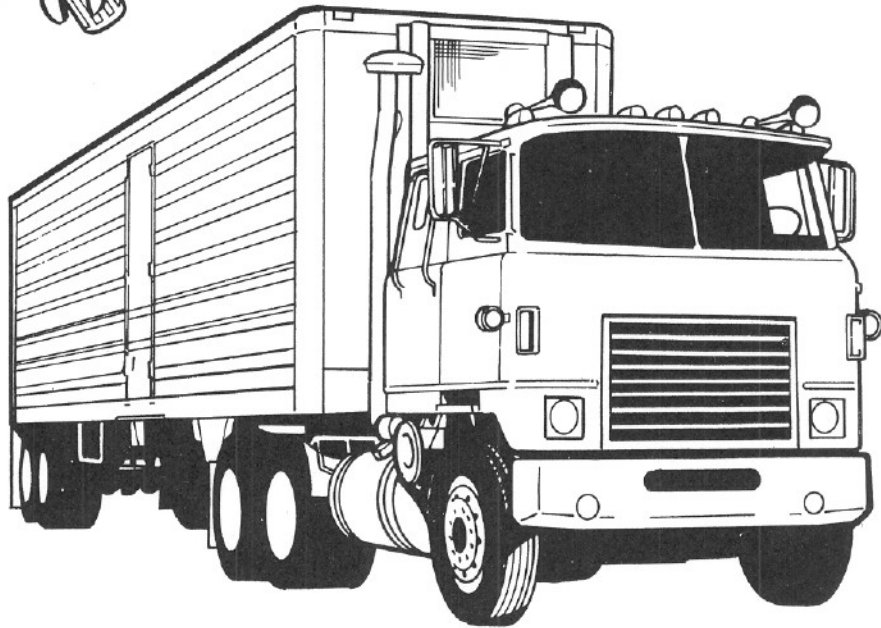
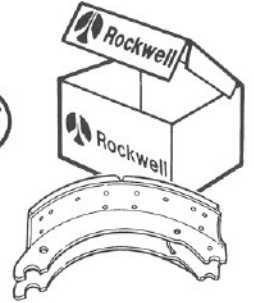

Rockwell International





Rockwell International

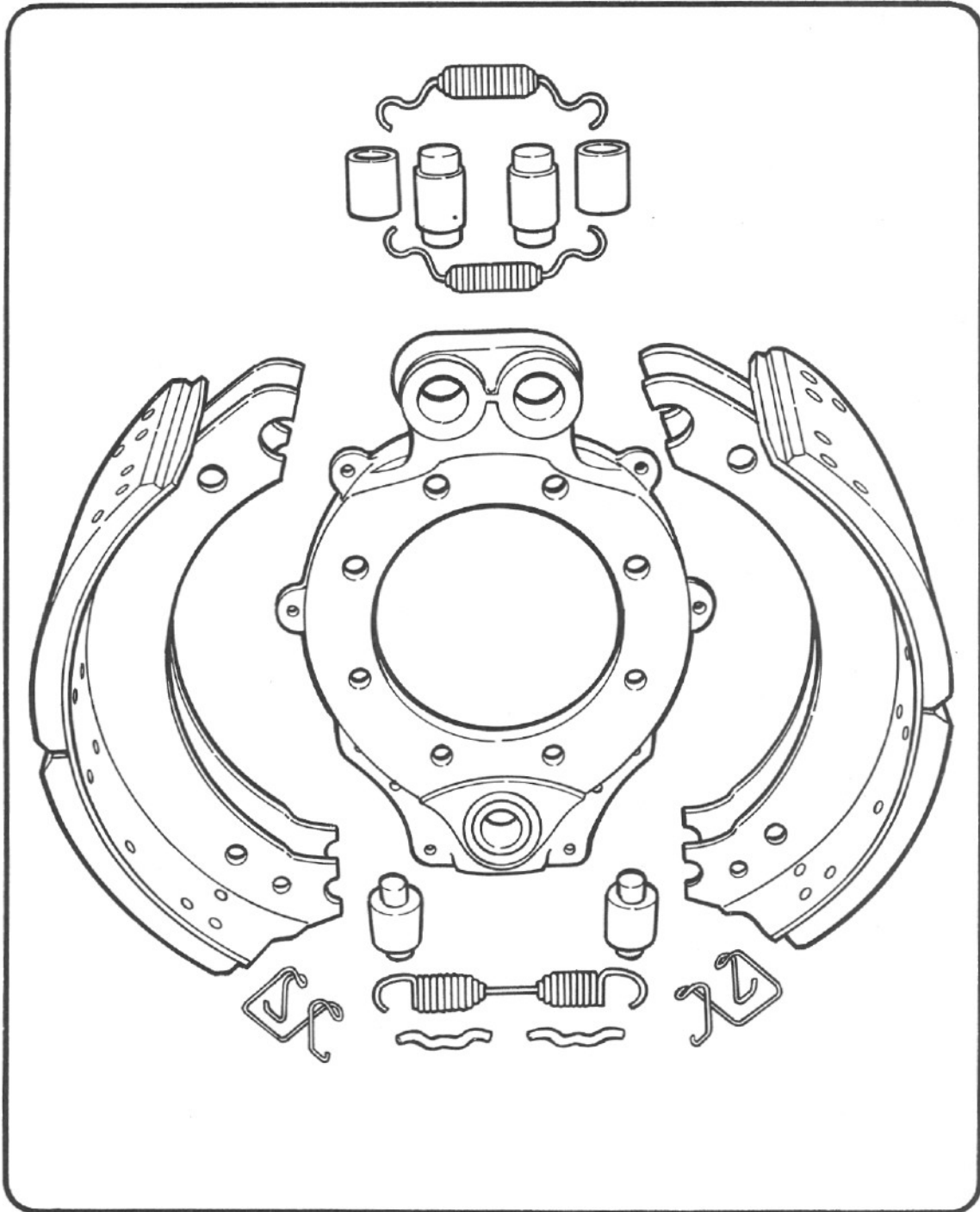

ell Inter

perations
1S
le Road
48084 U.S.A.

SYMBOL DEFINITIONS



- CONNECT
- PUT ON
- PUT IN PLACE



- REMOVE
- DISCONNECT
- TAKE OFF



- DO NOT REMOVE



- LOOK AT
- VISUALLY INSPECT



- CHECK
- PHYSICALLY CHECK
- MOVE COMPONENT



- OKAY
- SATISFACTORY
- LIKE IT SHOULD BE



- NOT OKAY
- UNSATISFACTORY
- NOT LIKE IT SHOULD BE



TURN CLOCKWISE



TURN CLOCKWISE NUMBER OF TURNS SHOWN (3 IN THIS EXAMPLE)



TURN COUNTERCLOCKWISE



TURN COUNTERCLOCKWISE NUMBER OF TURNS SHOWN (2 IN THIS EXAMPLE)



- GREASE
- LUBRICATE
- REPACK



- ADD OIL
- OIL AS NEEDED



18

PROCEED TO STEP SHOWN (STEP 18 IN THIS EXAMPLE)



SEQUENCE (EXAMPLE SHOWN: FIRST, DISCONNECT — SECOND, TURN CLOCKWISE)



SHOWS DIRECTION OF PUSH OR PULL



REPLACE WITH NEW PART



NUMBER



TORQUE AS INDICATED



STOP — YOU ARE FINISHED



- CLEAN
- WIPE CLEAN



- SLIGHT DRAG
- SLIGHT RESISTANCE

DEFINITIONS DES SYMBOLES

- BRANCHER
- METTRE
- METTRE EN PLACE

- RETIRER
- DEBRANCHER
- ENLEVER

- NE PAS RETIRER

- EXAMINER
- INSPECTER A VUE

- VERIFIER
- VERIFIER PHYSIQUEMENT
- BOUGER L'ORGANE

- BIEN
- SATISFAISANT
- COMME DEVRAIT ETRE

- NE VA PAS
- PAS SATISFAISANT
- NE PAS COMME DEVRAIT ETRE

TOURNER VERS LA DROITE

NOMBRE DE TOURS VERS LA DROITE (3 EN CETTE INSTANCE)

TOURNER VERS LA GAUCHE

NOMBRE DE TOURS VERS LA GAUCHE (2 EN CETTE INSTANCE)

- GRAISSER
- LUBRIFIER
- REGARNIR

- AJOUTER DE L'HUILE
- HUILE LORSQUE NECESSAIRE

PROCEDER A L'ETAPE INDIQUEE (ETAPE 18 EN CETTE INSTANCE)

SEQUENCE (EXEMPLE DEMONTRE: D'ABORD DEBRANCHER — ENSUITE, TOURNER VERS LA DROITE)

TIRER OU POUSSER DANS CETTE DIRECTION

REPLACER AVEC UNE NOUVELLE PIECE

NUMERO

RESSERRER COMME INDIQUE

ARRETEZ — VOUS AVEZ TERMINE

- NETTOYER
- NETTOYER EN ESSUYANT

- LEGER FROTTEMENT
- LEGERE RESISTANCE

"Important: Brake linings contain asbestos fibers. Caution should be exercised in handling and maintenance as described in O.S.H.A. Regulation (29 CFR PART 1910.1001)."

"Important: Les garnitures de freins contiennent des fibres d'asbeste. Faire très attention à la manipulation et à l'entretien comme prescrit par le règlement O.S.H.A. (29 CFR PART 1910.1001)."

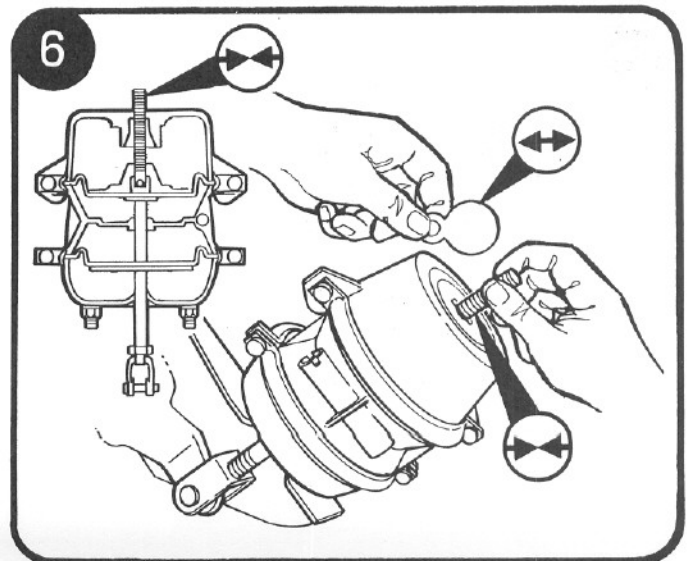
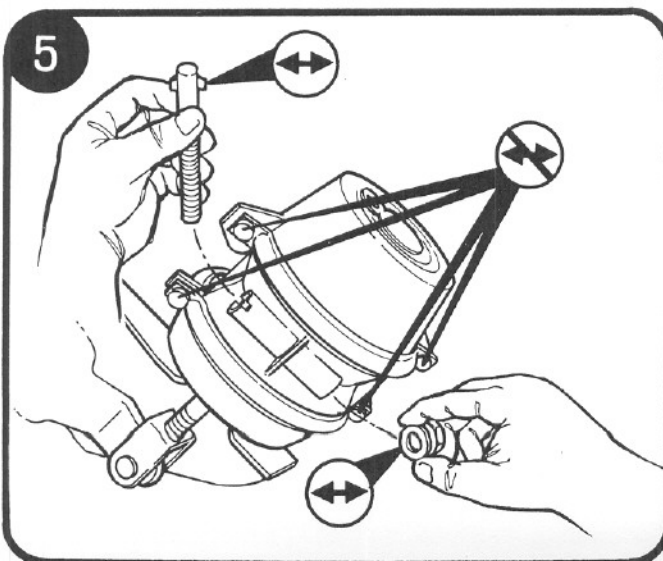
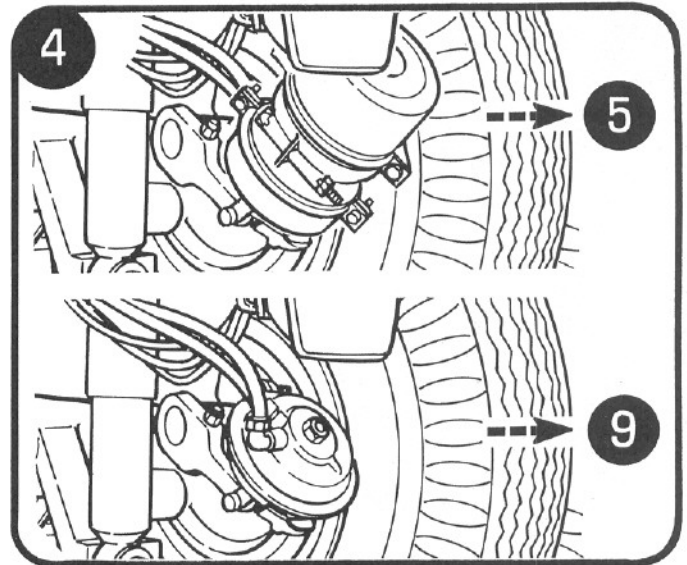
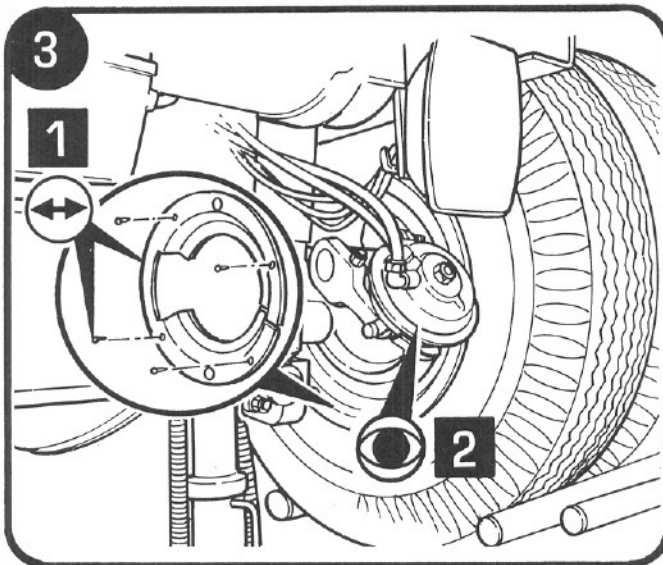
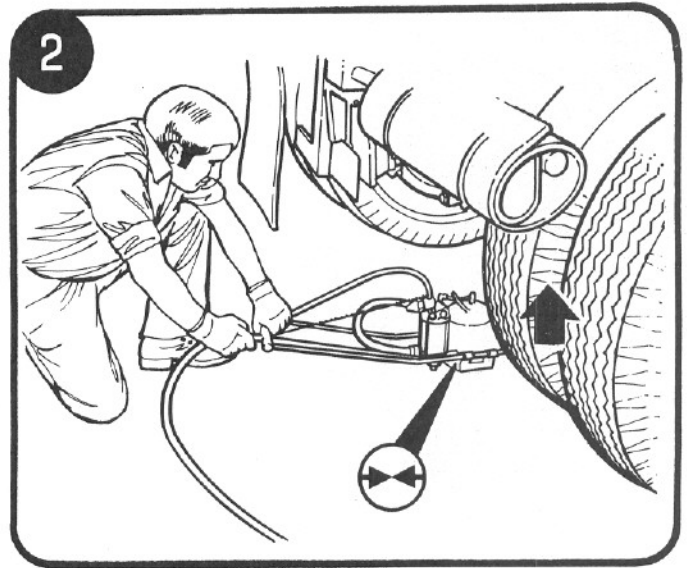
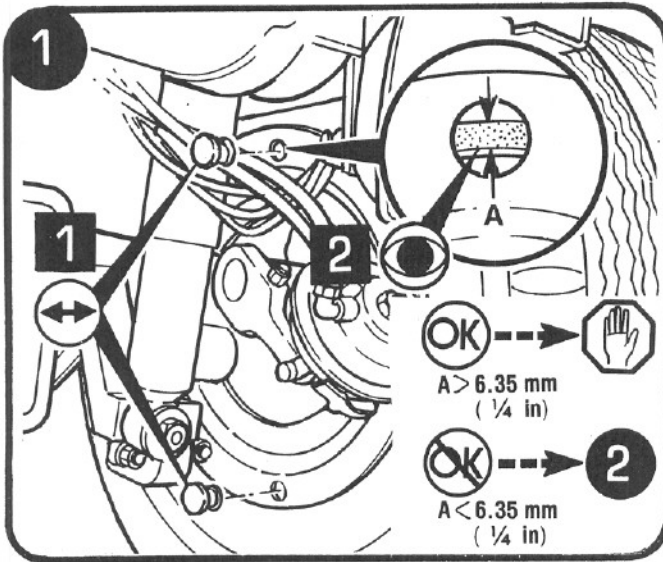

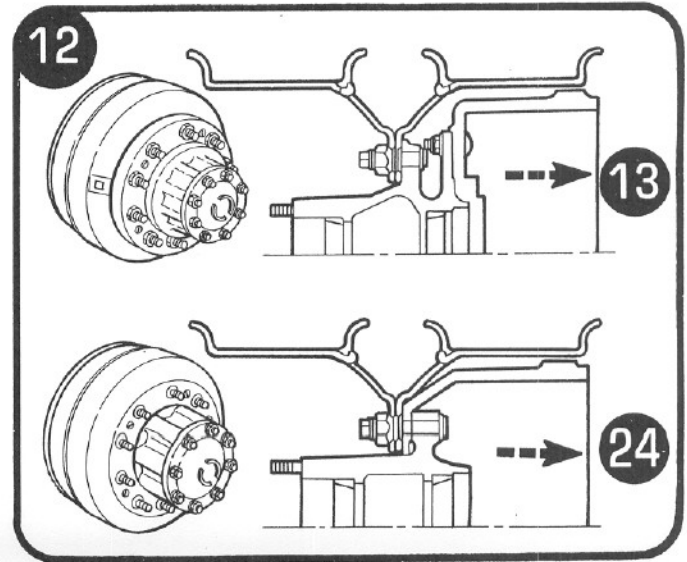
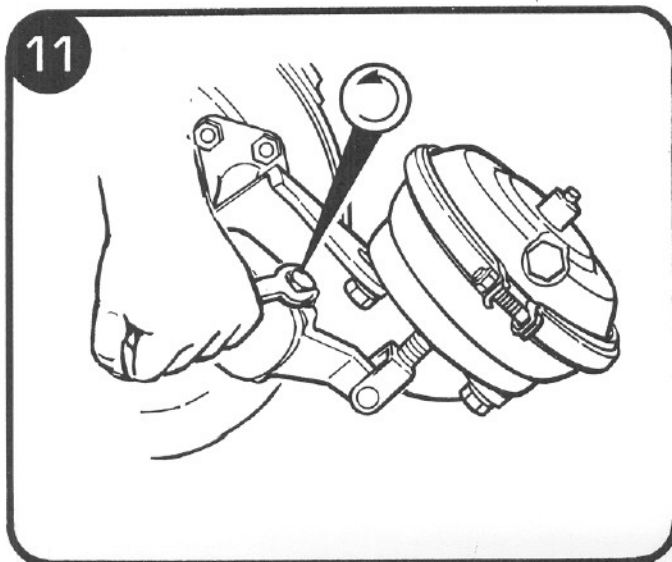
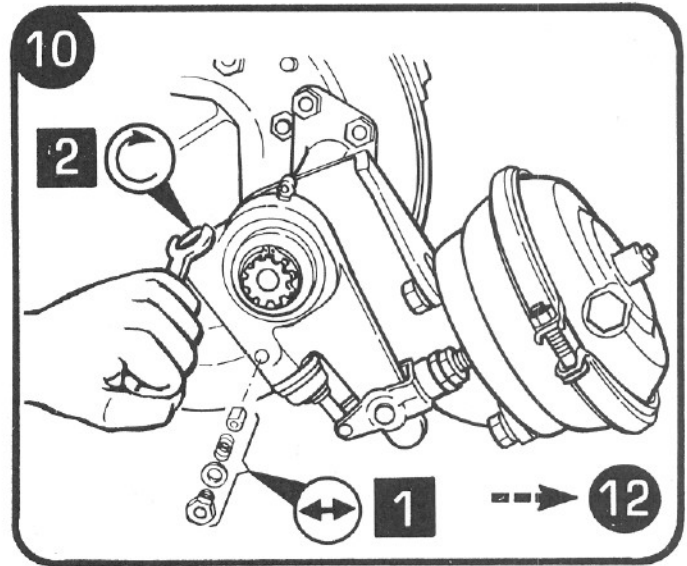
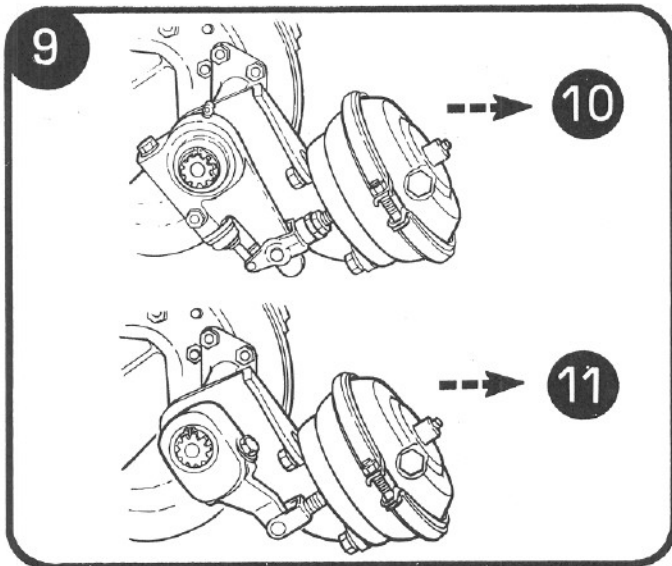
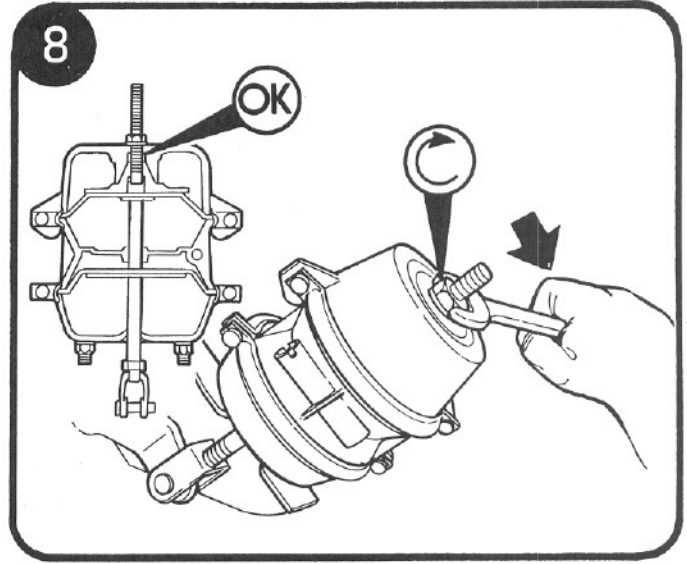
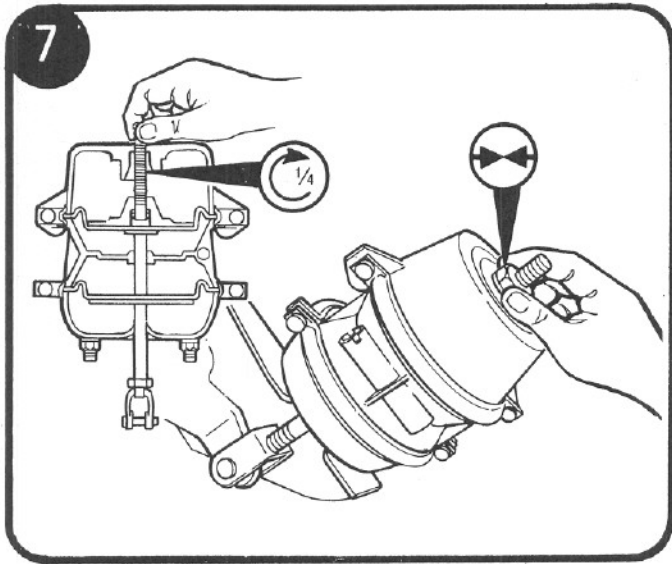

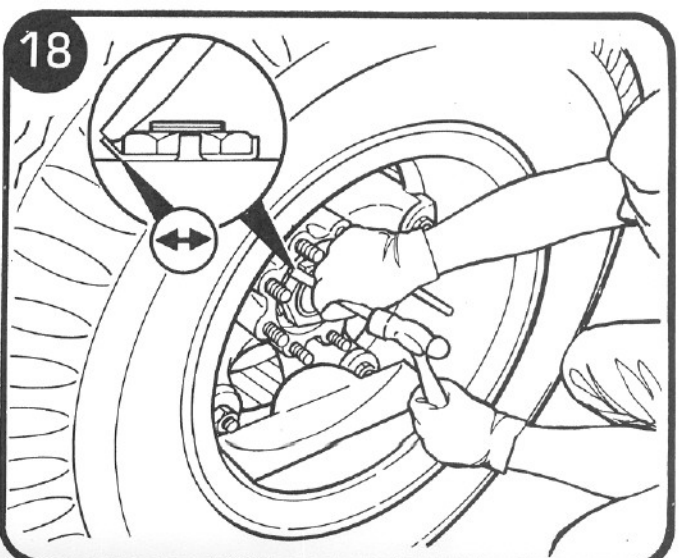
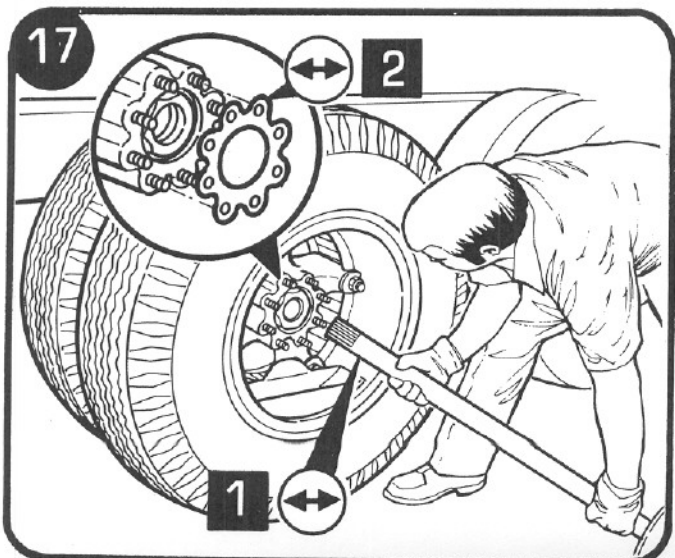
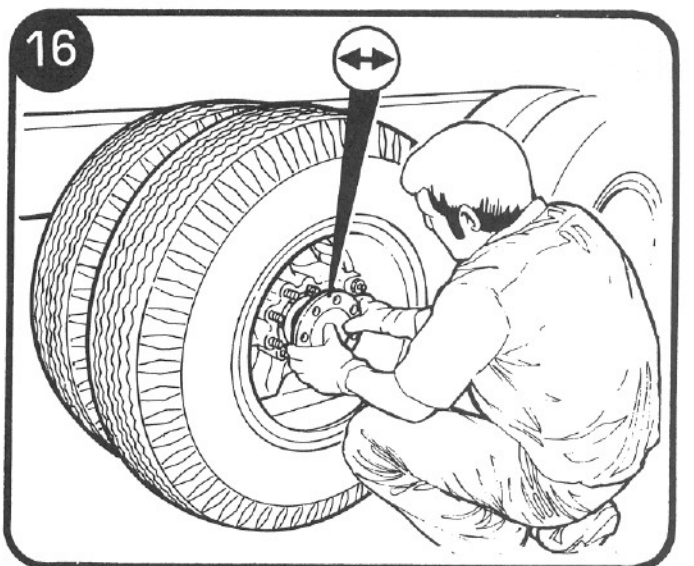
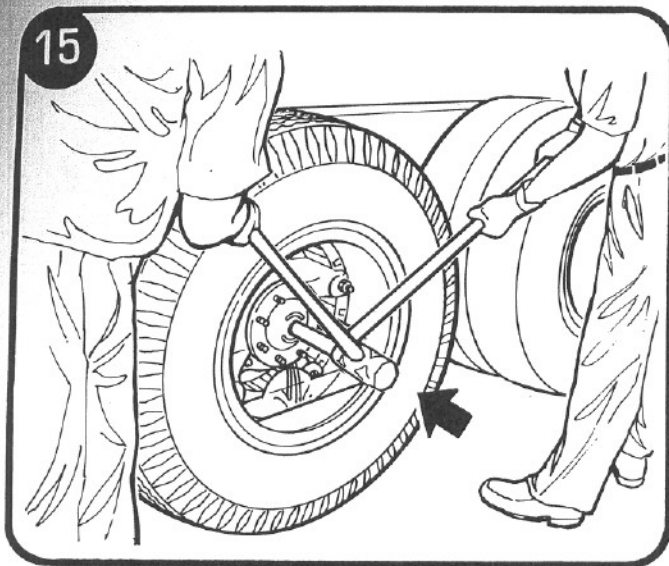
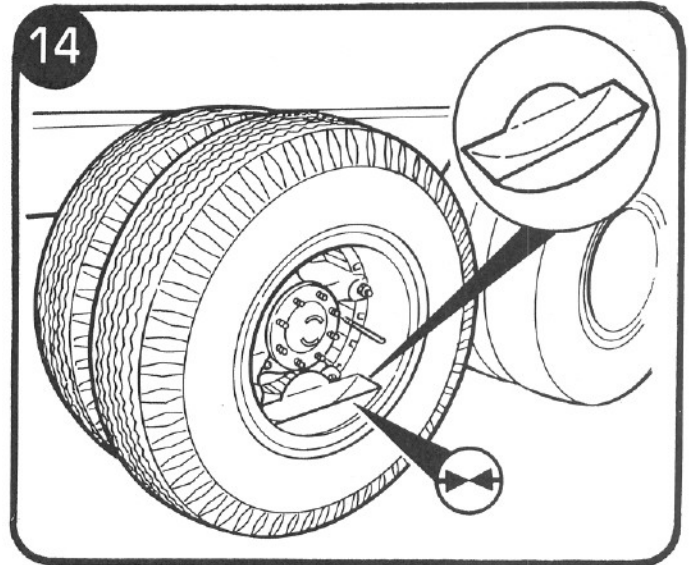
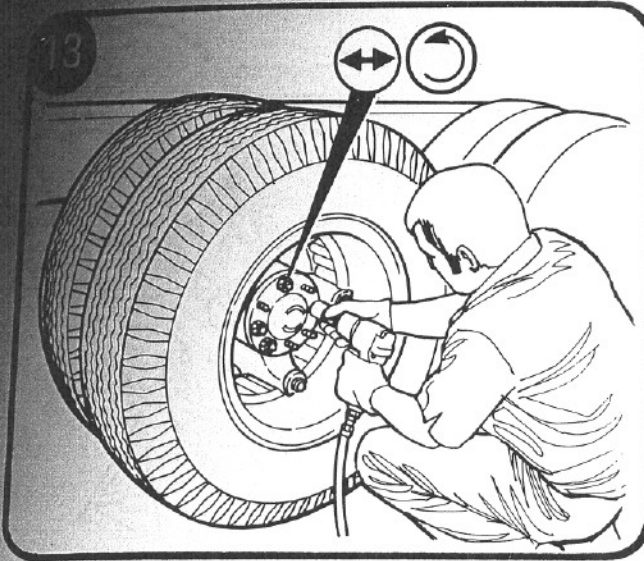

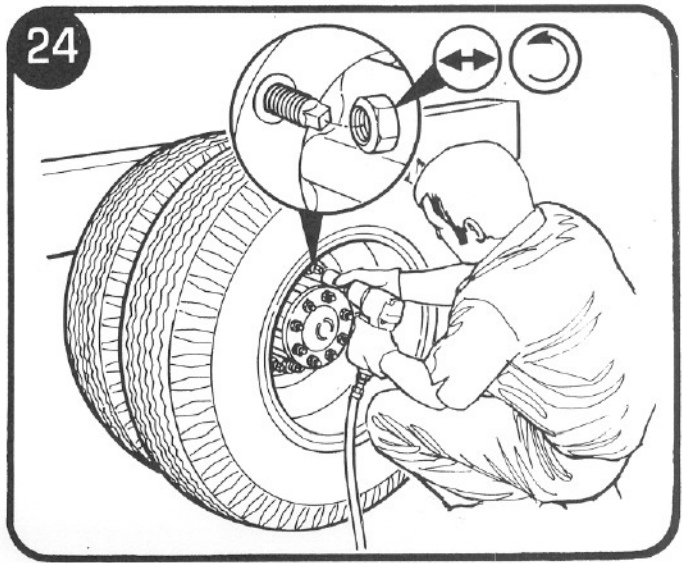
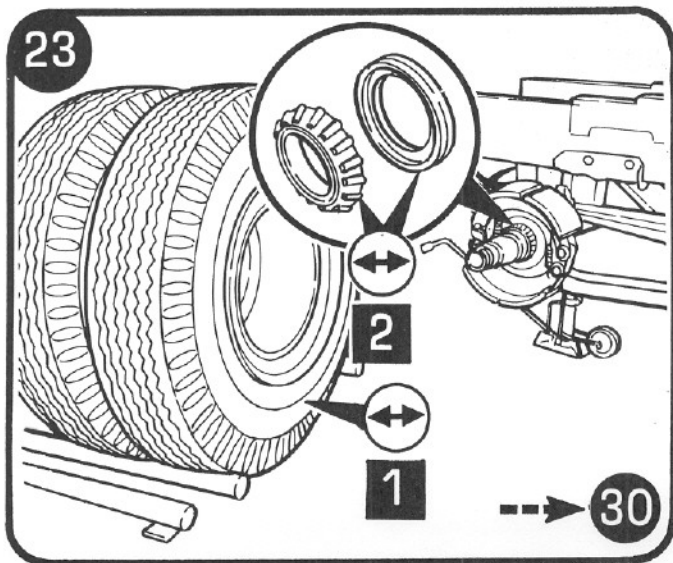
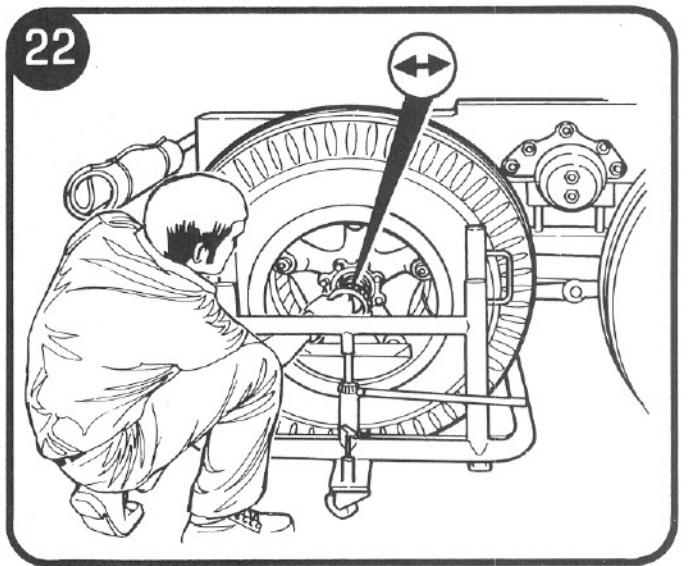
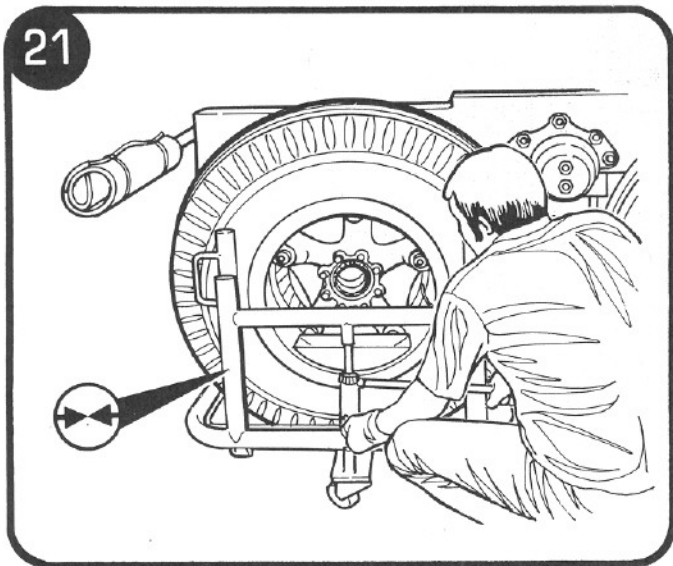
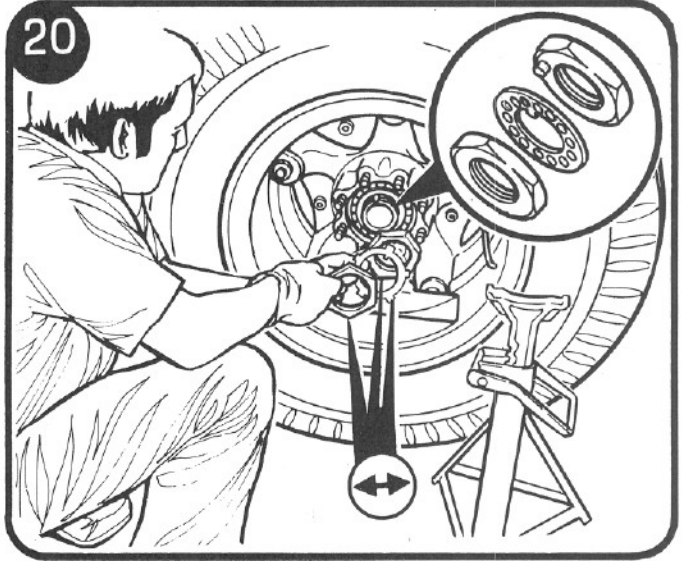
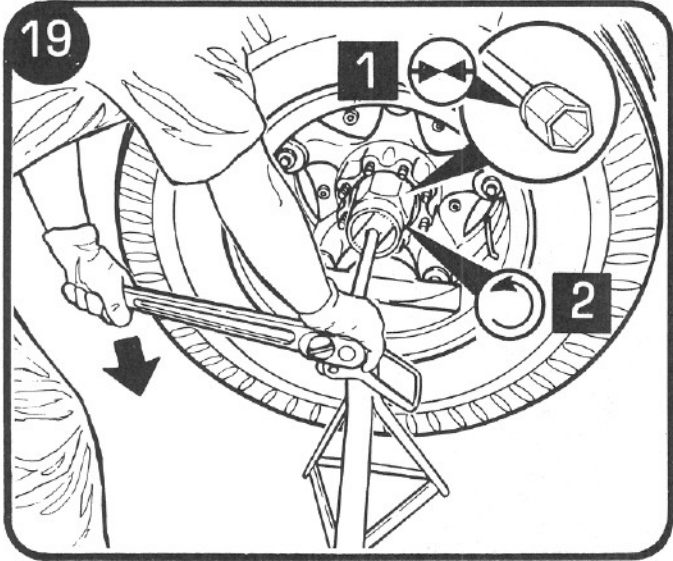

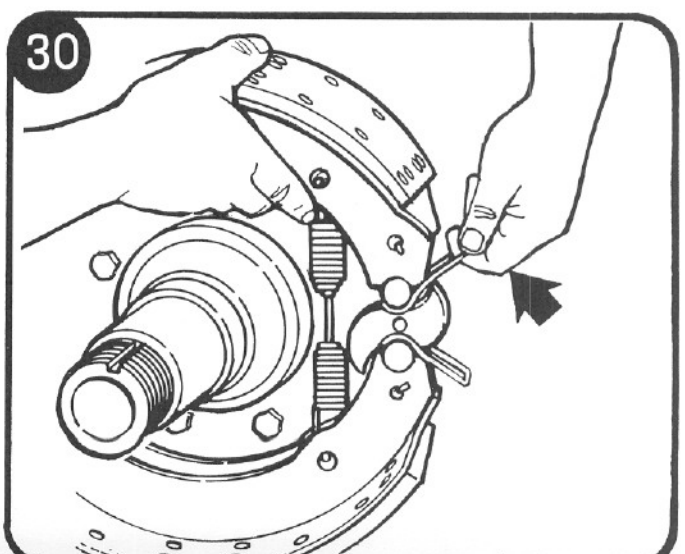
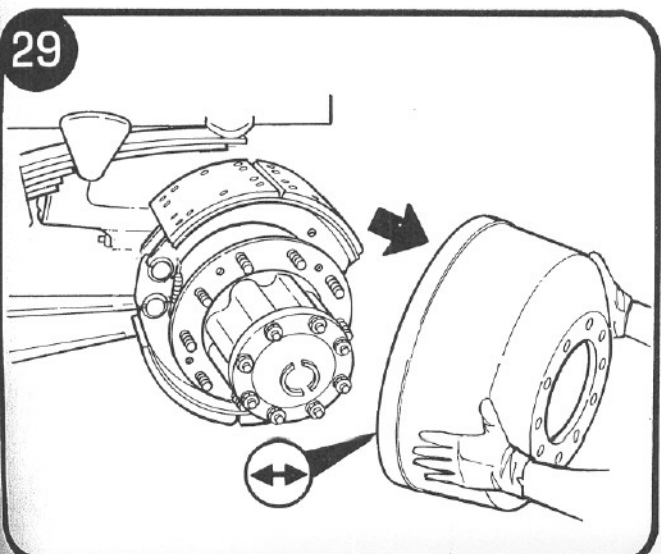
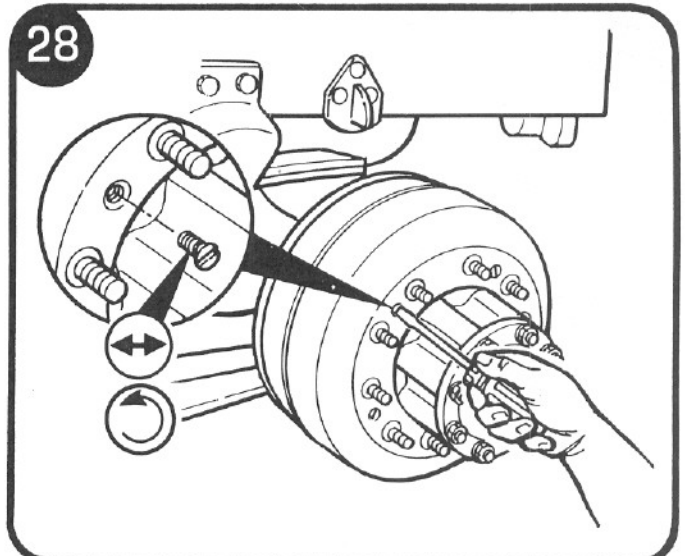
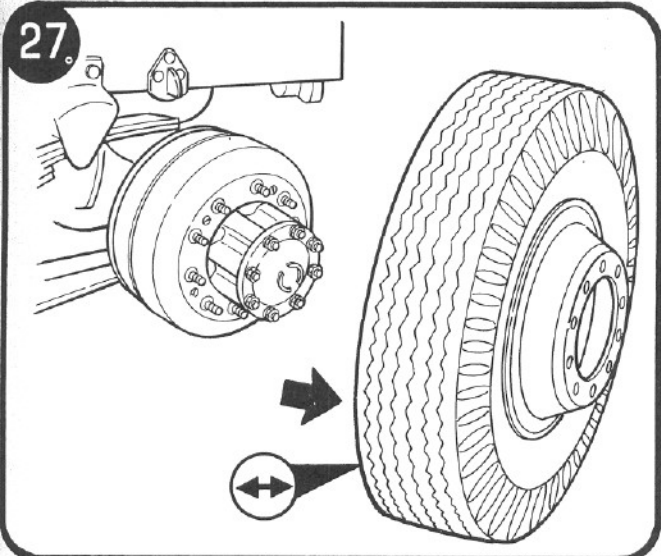
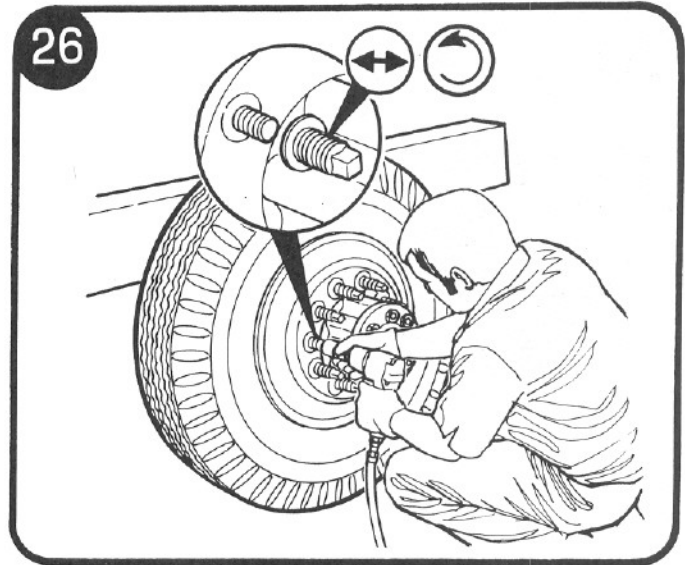
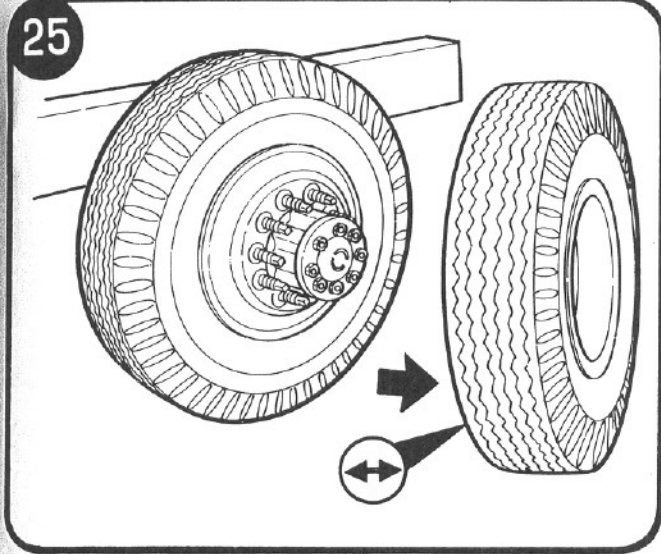

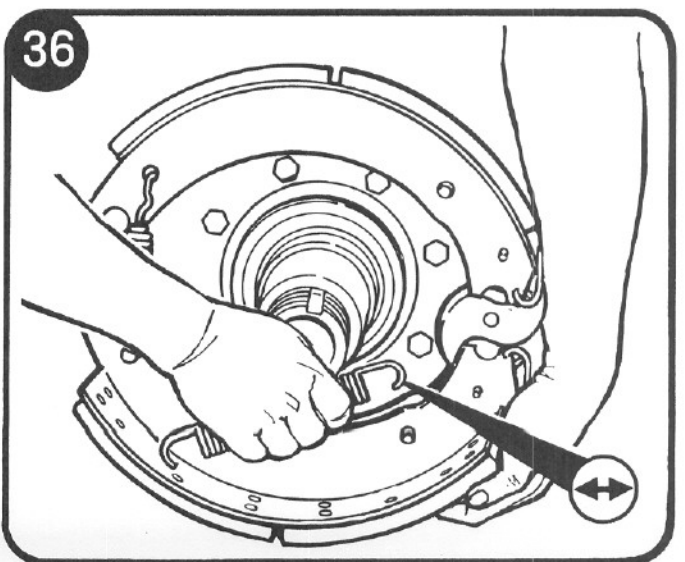
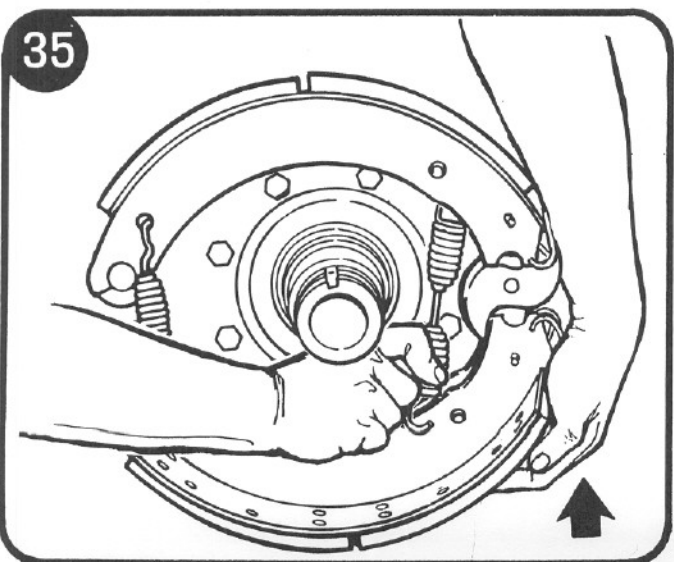
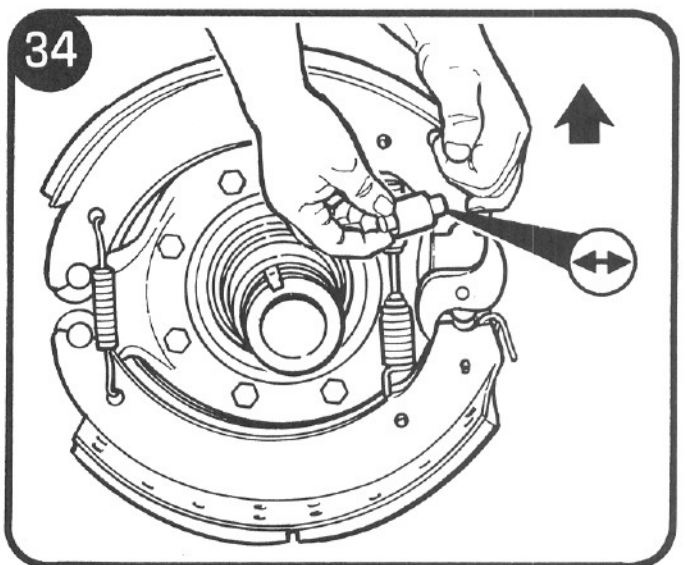
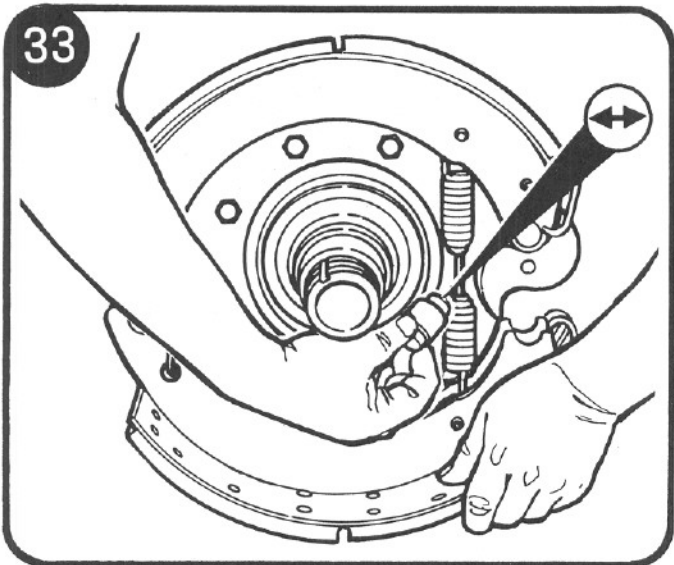
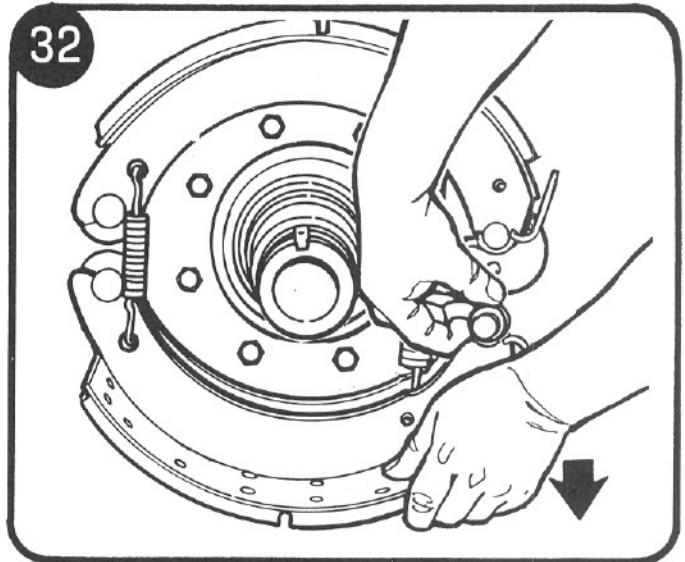
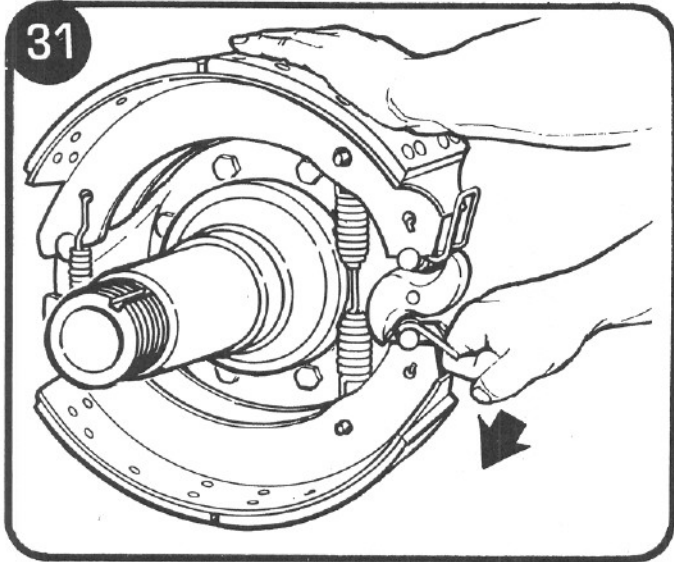

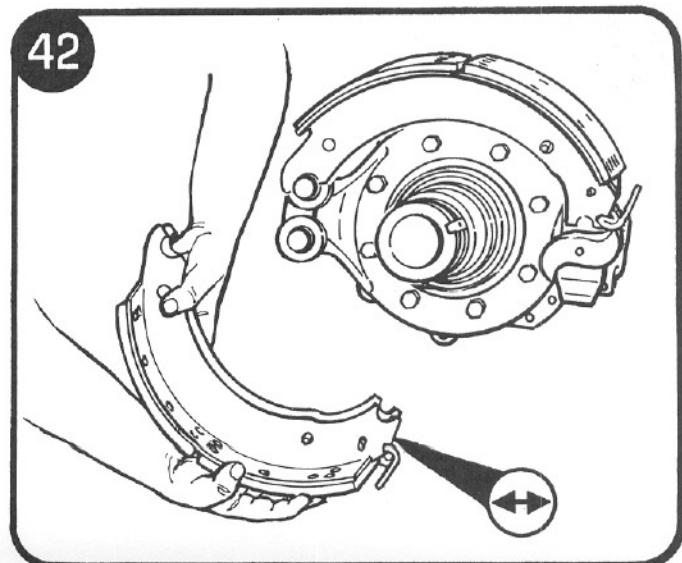
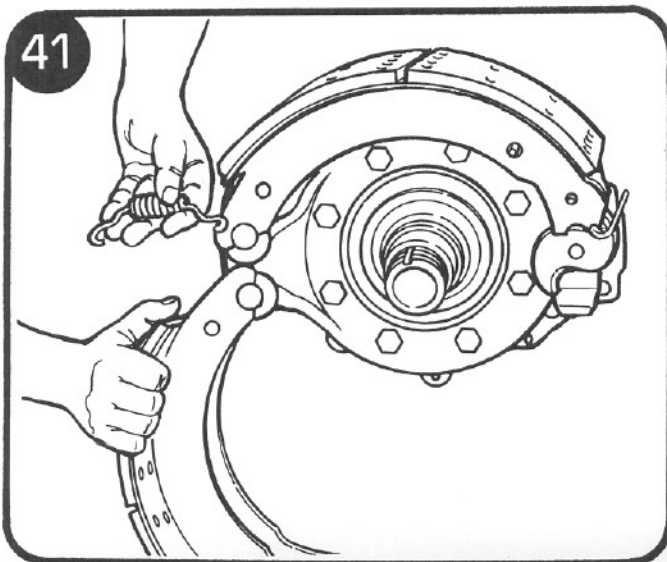
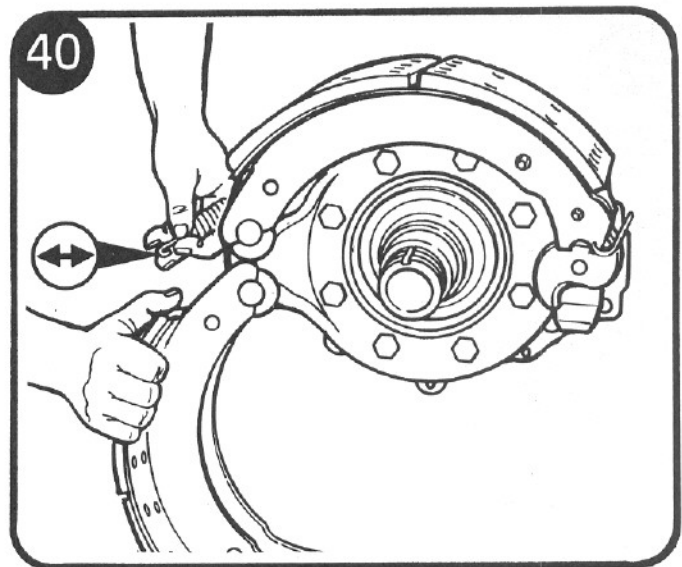
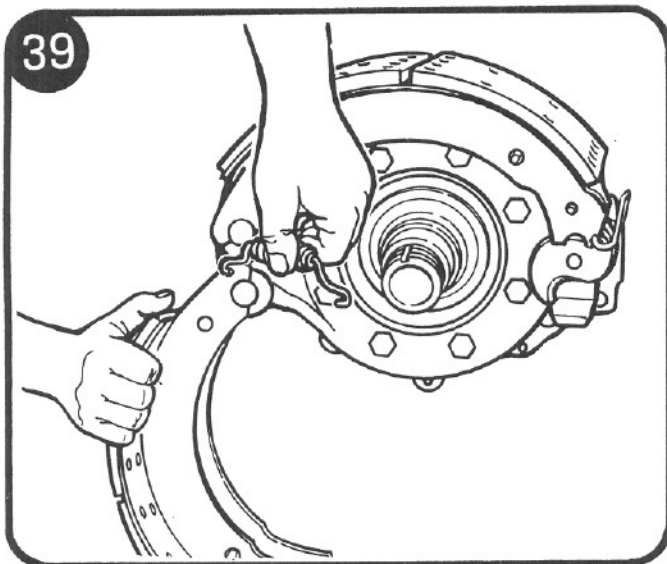
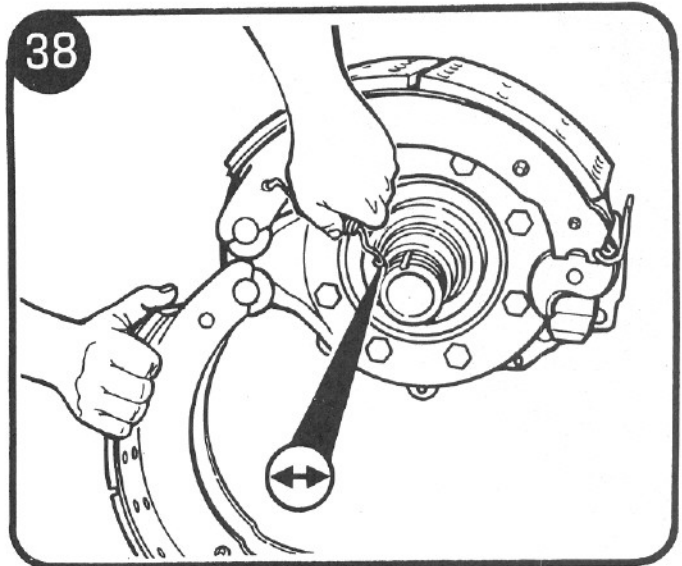
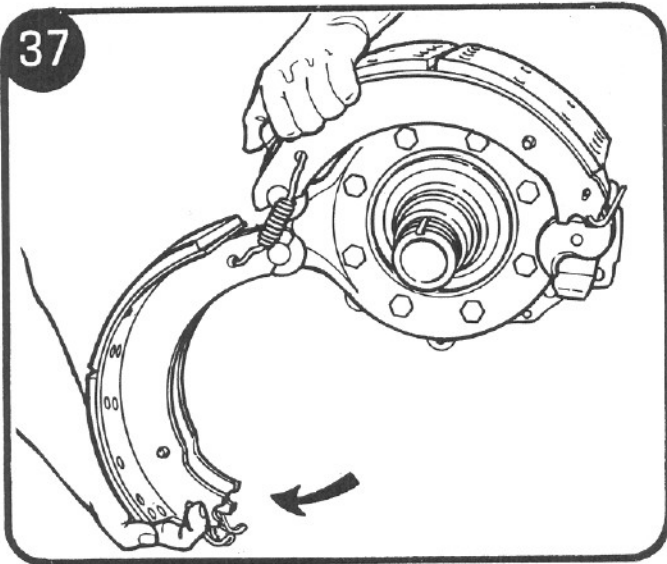

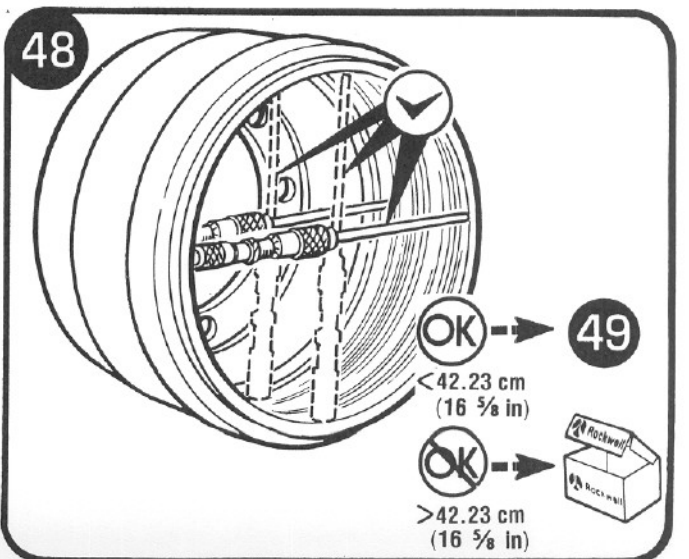
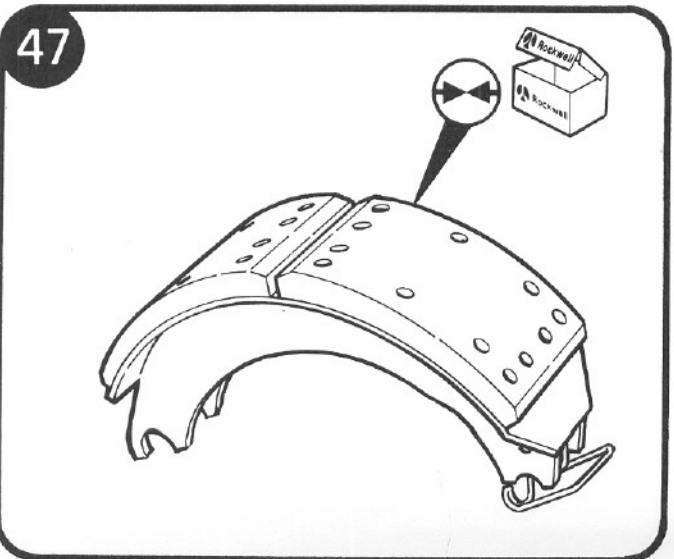
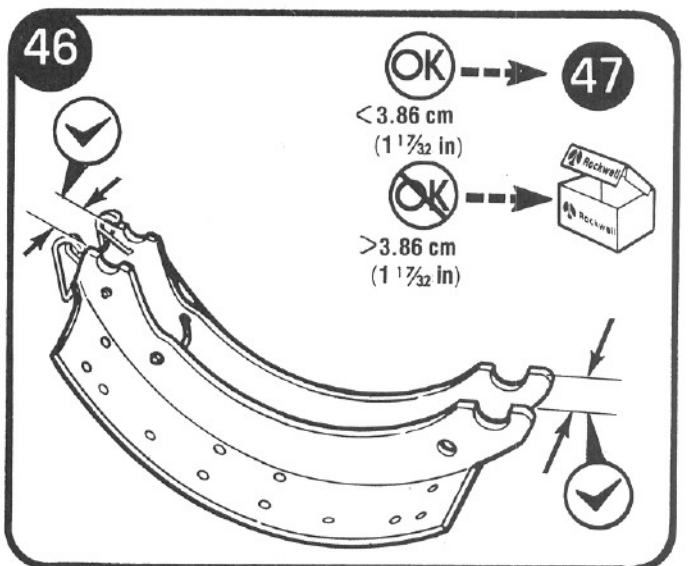
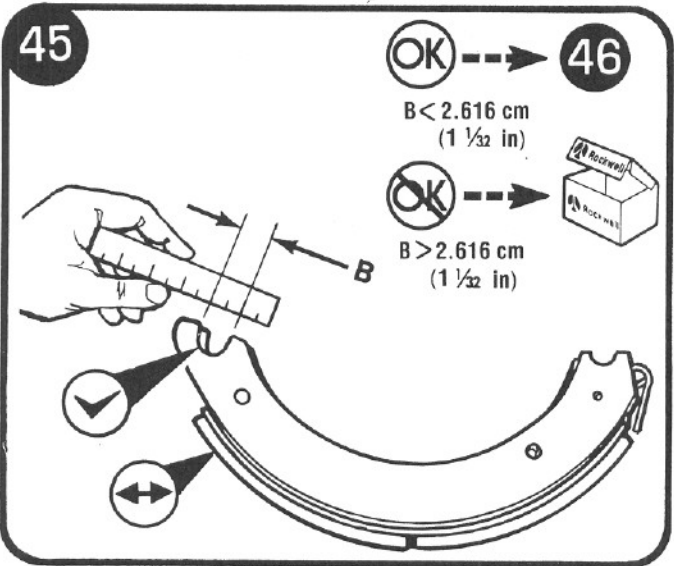
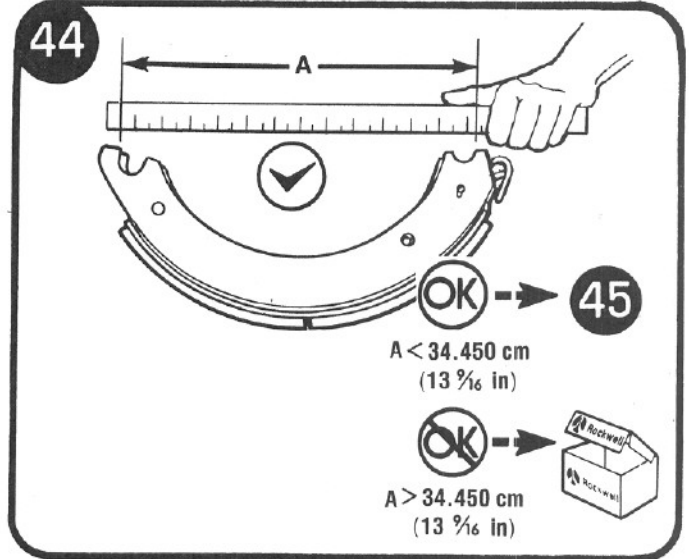
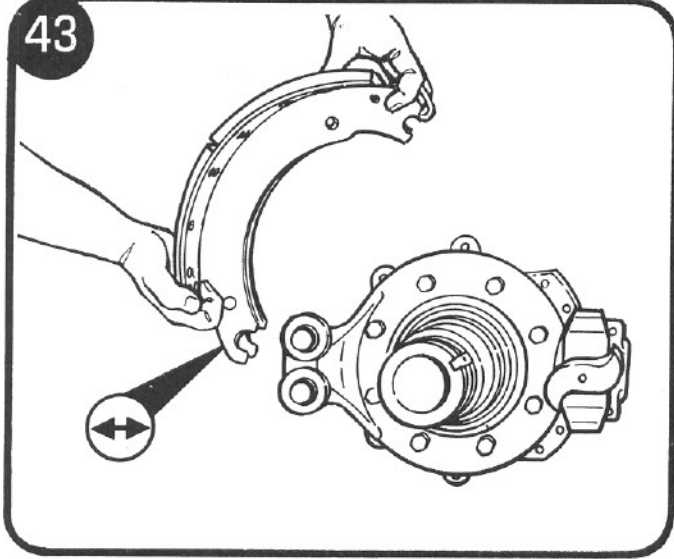

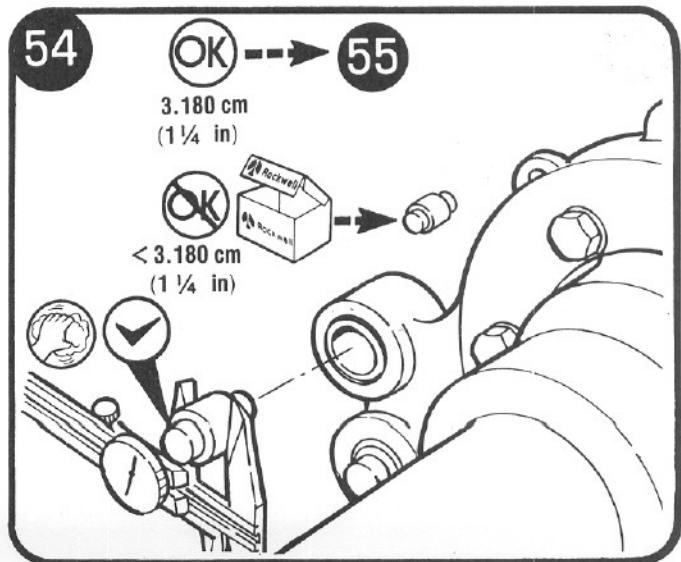
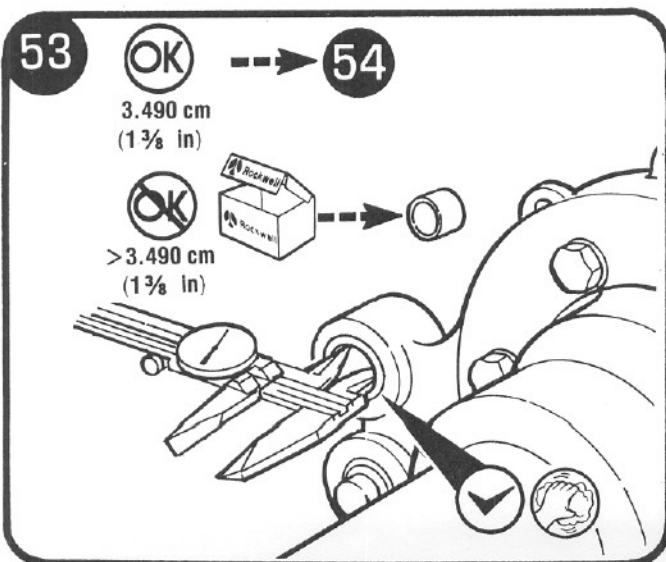
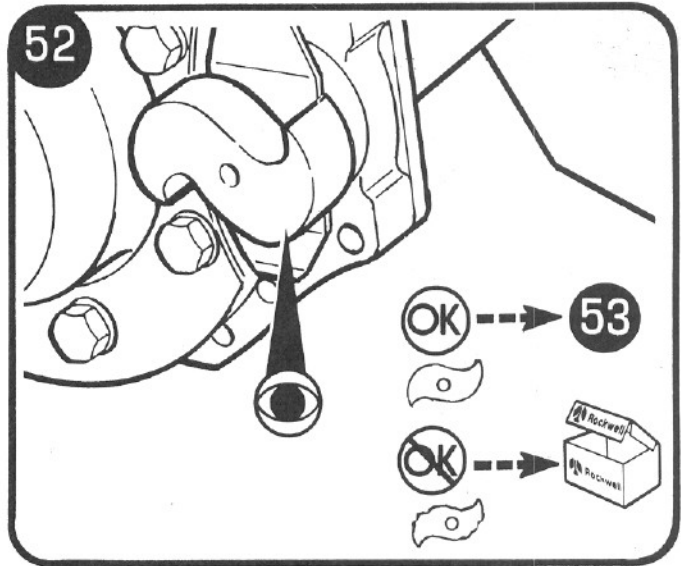
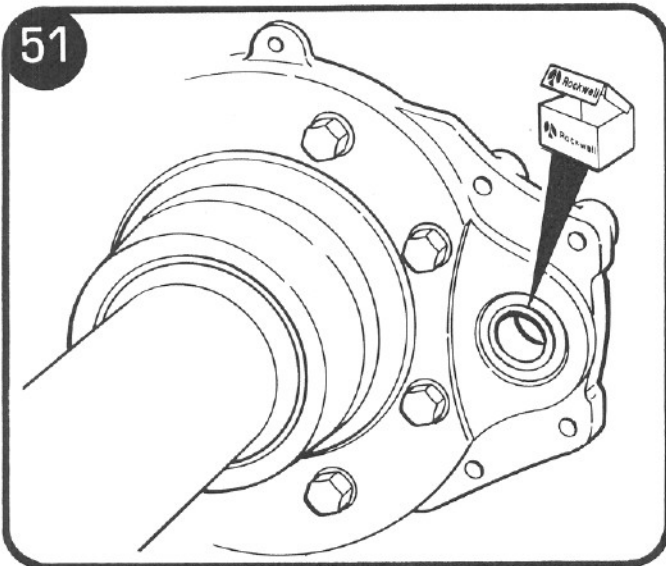
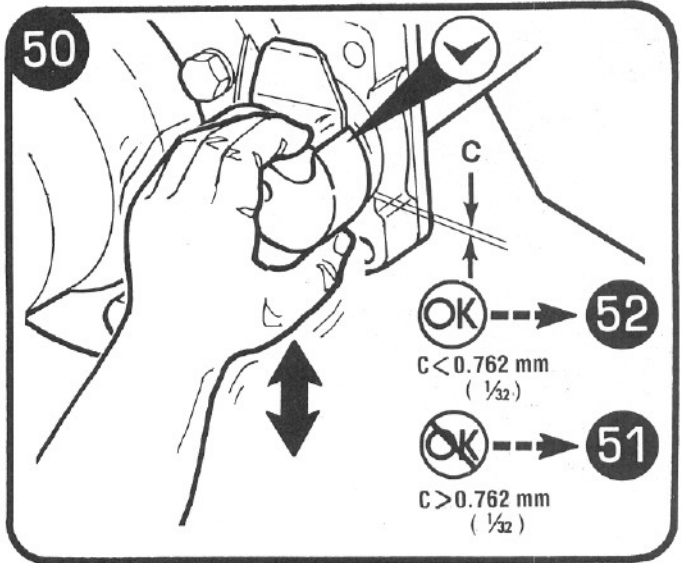
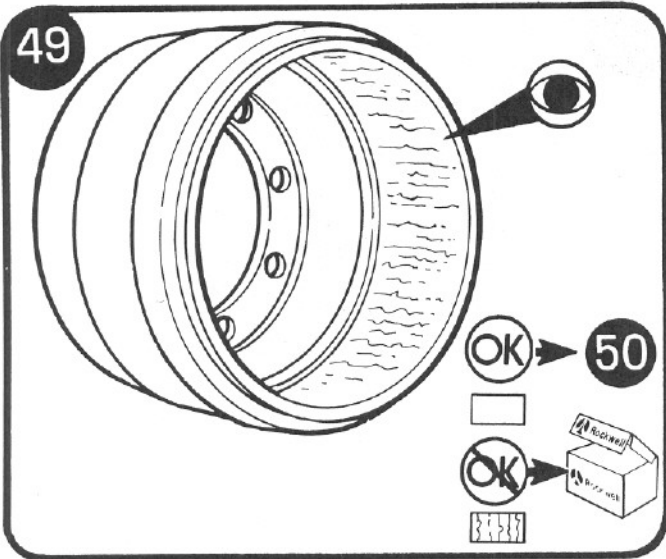

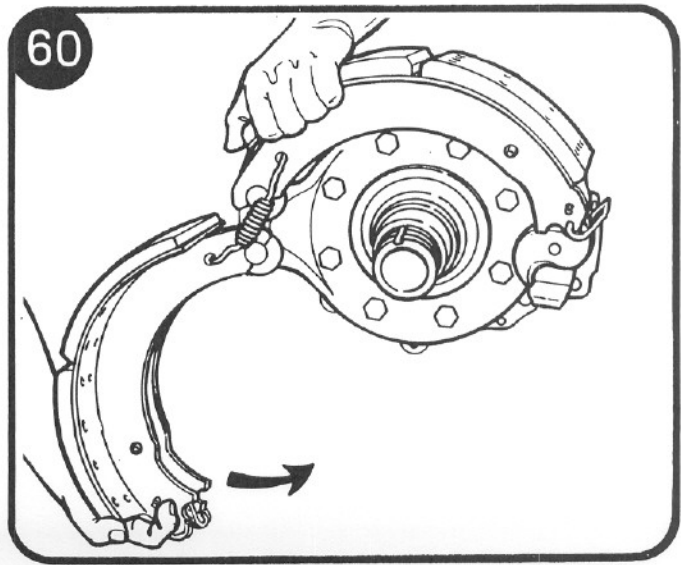
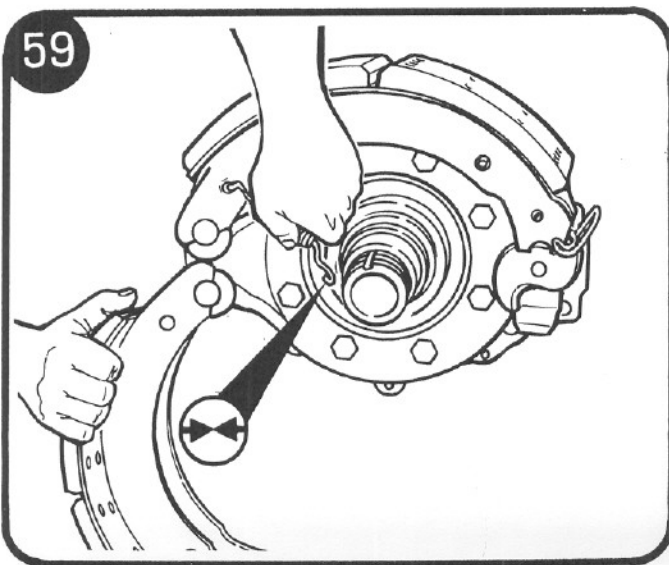
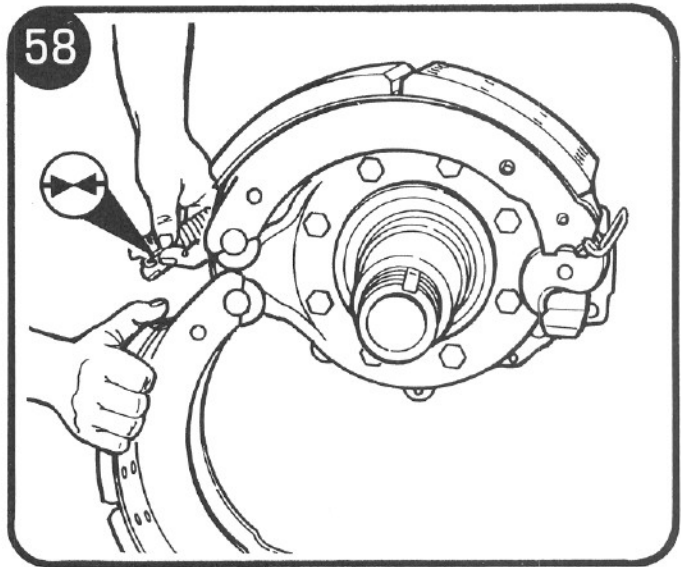
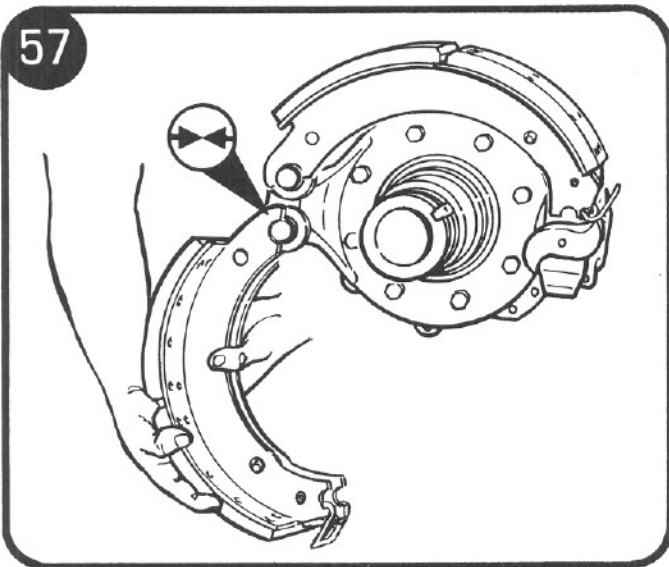
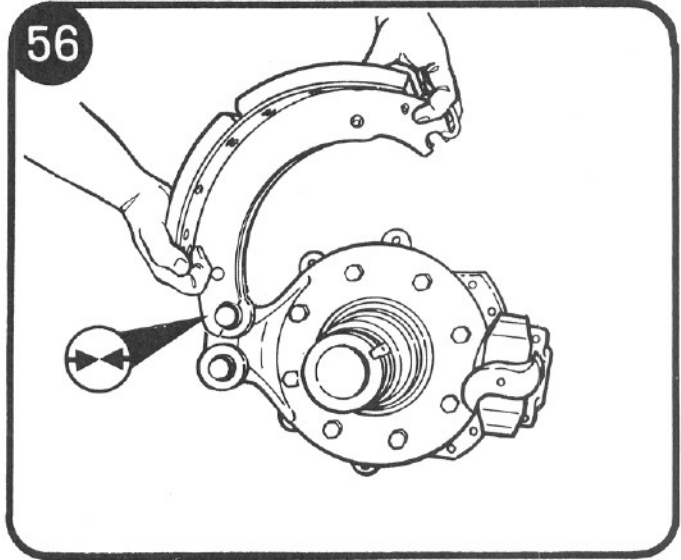
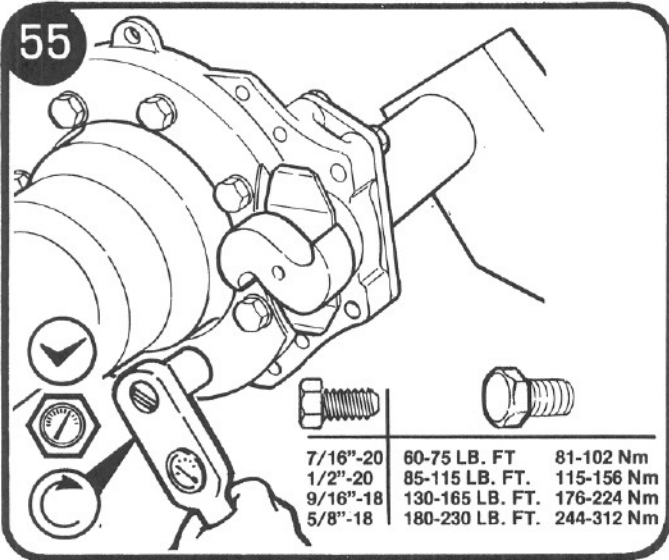

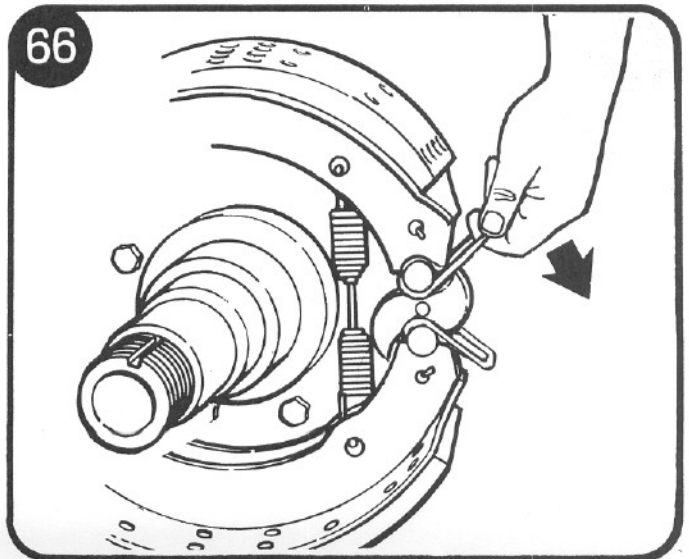
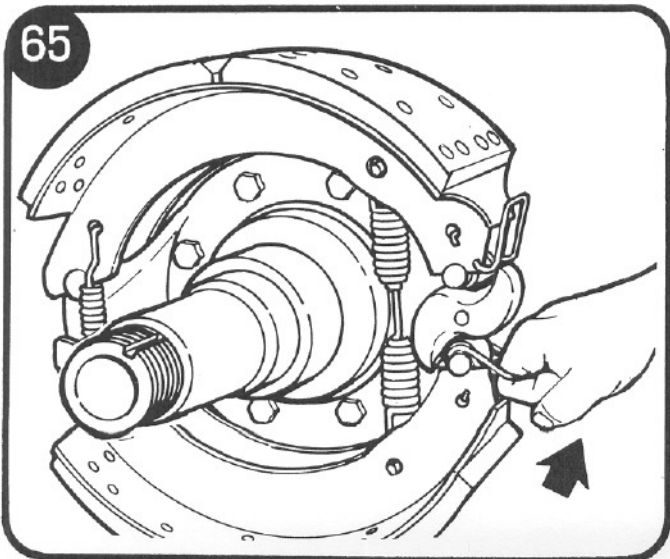
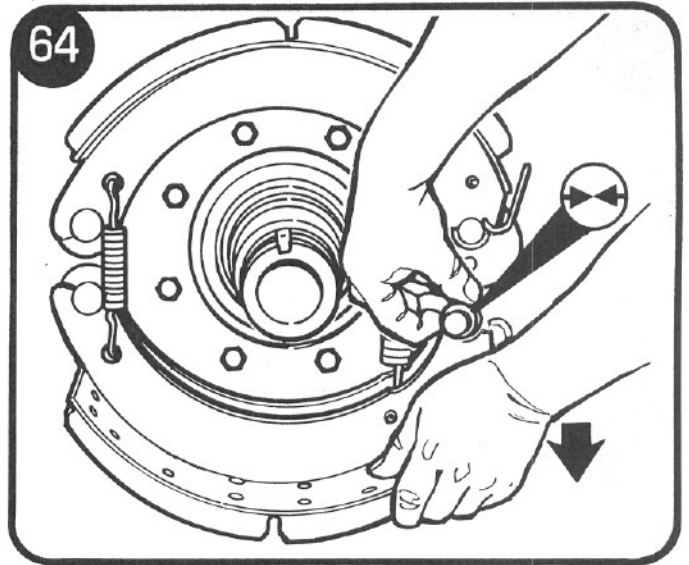
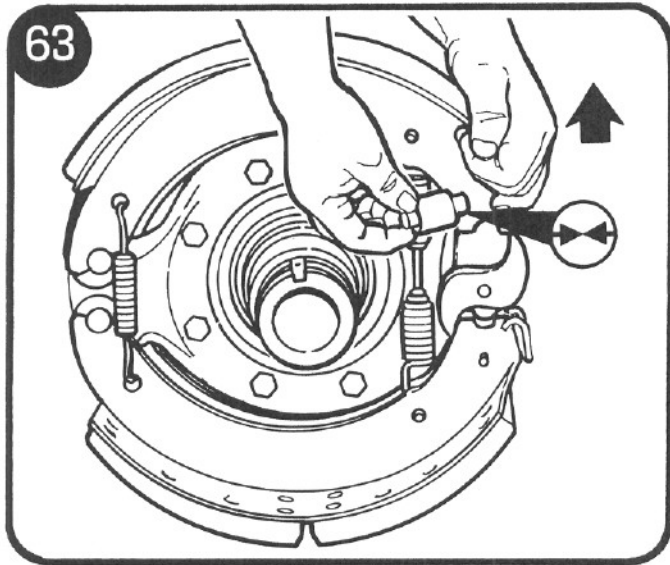
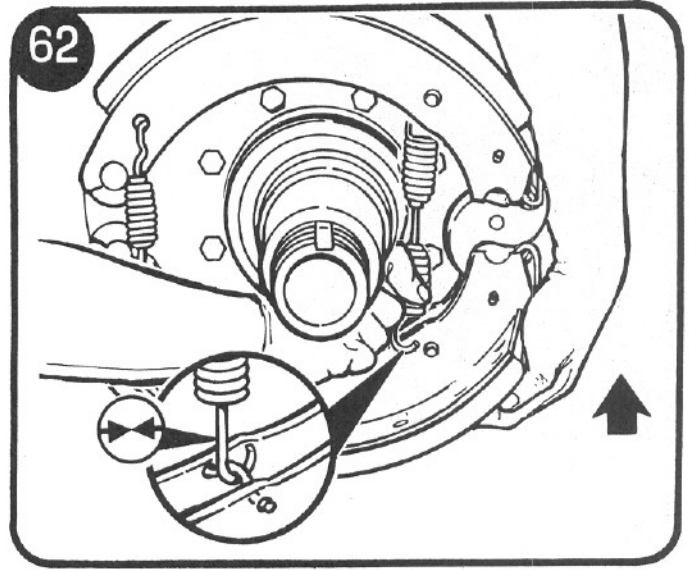
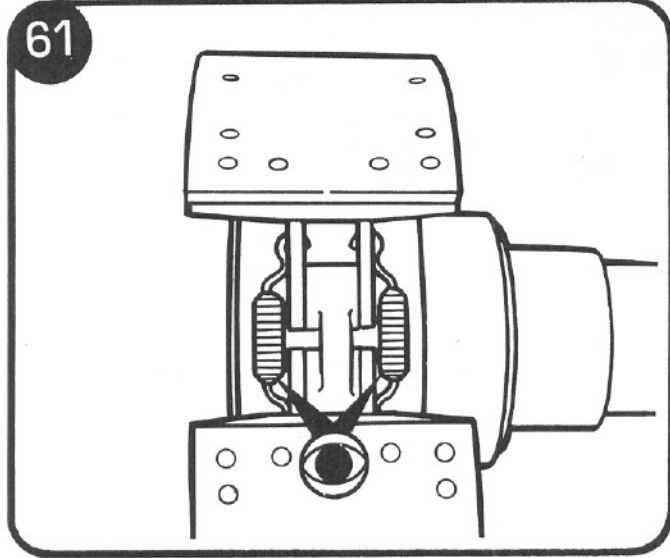

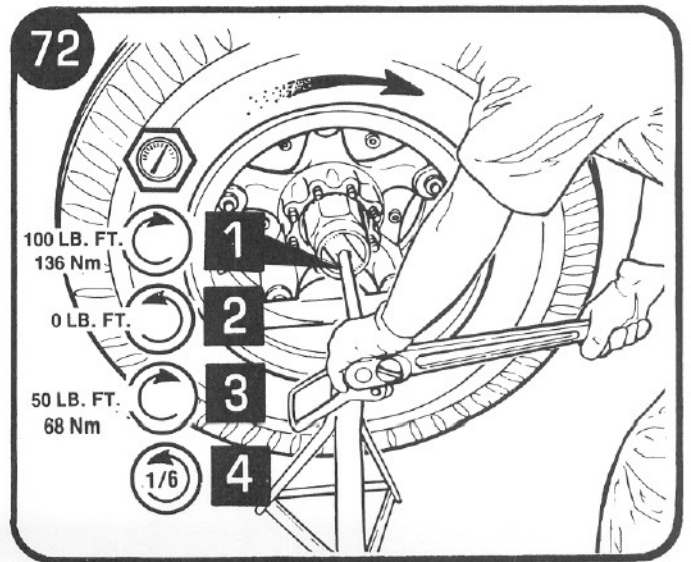
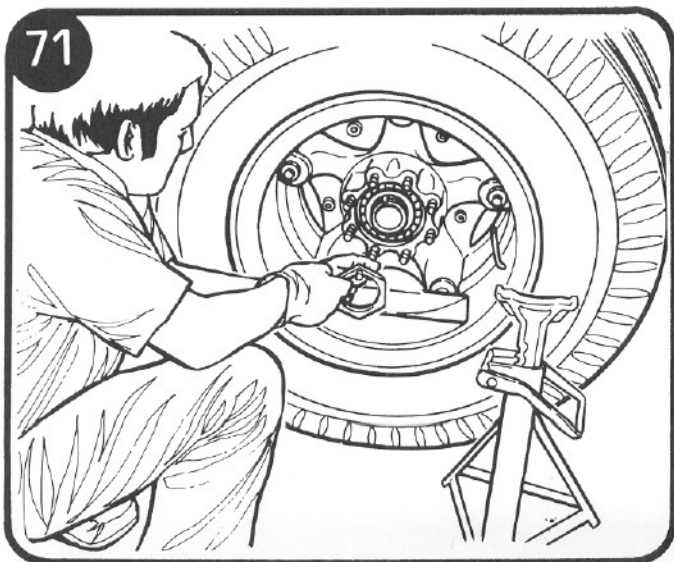
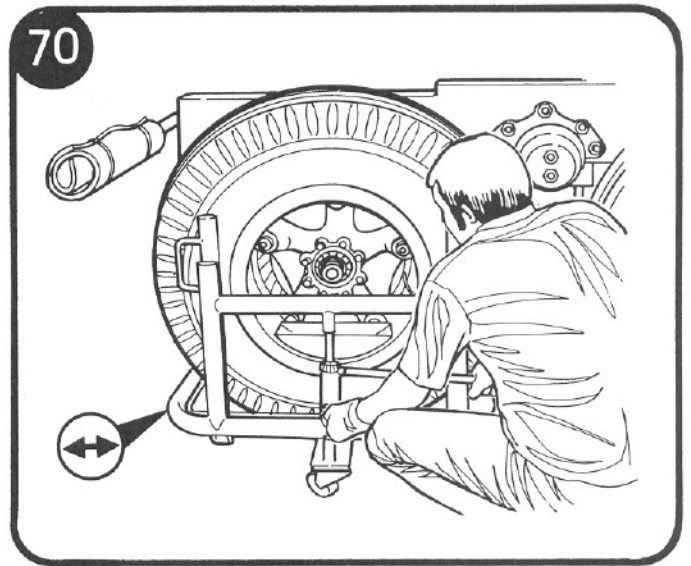
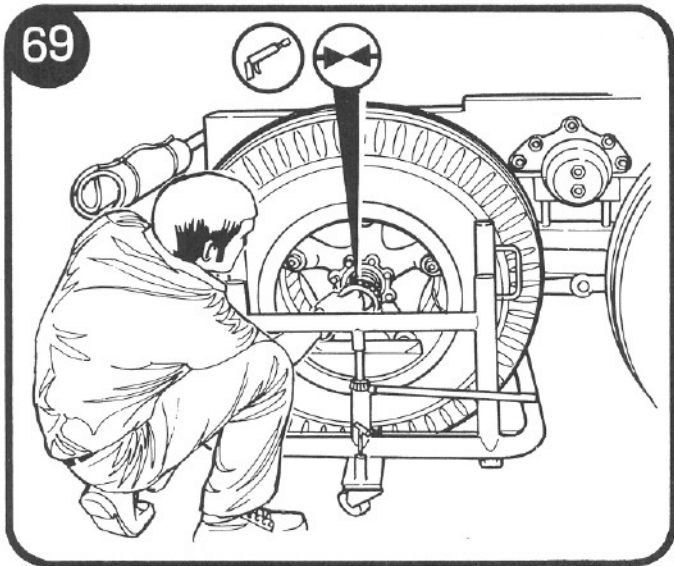
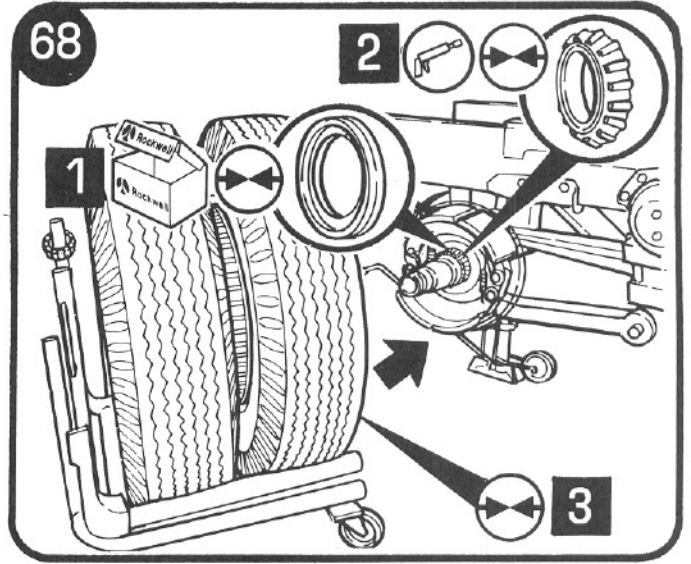
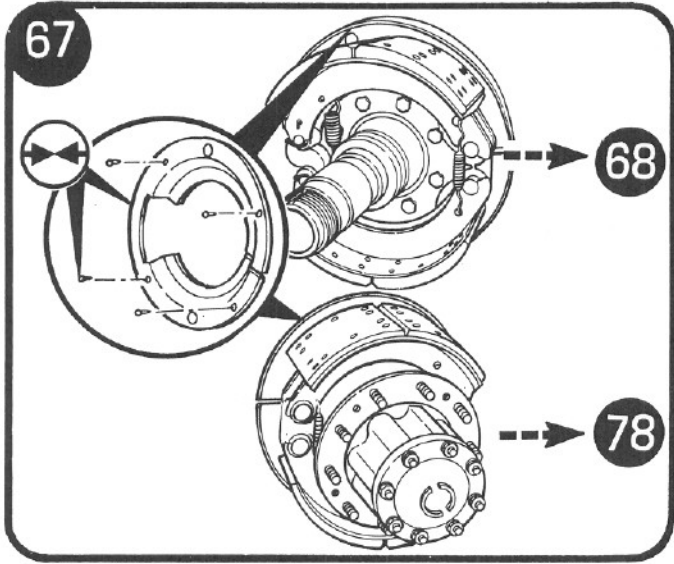

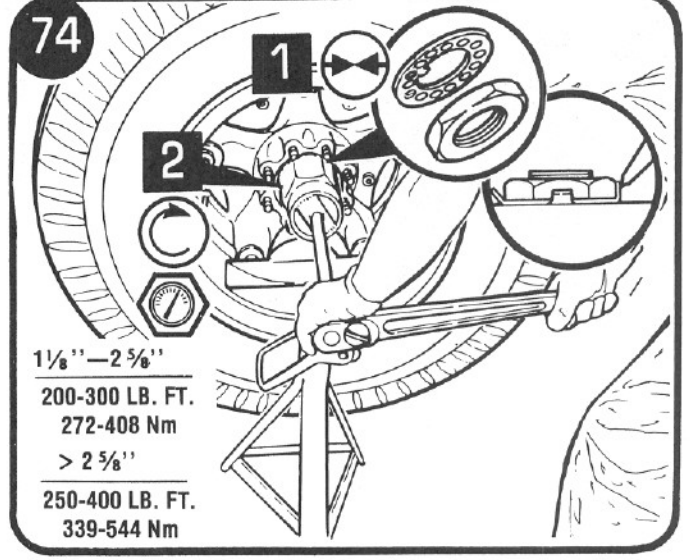
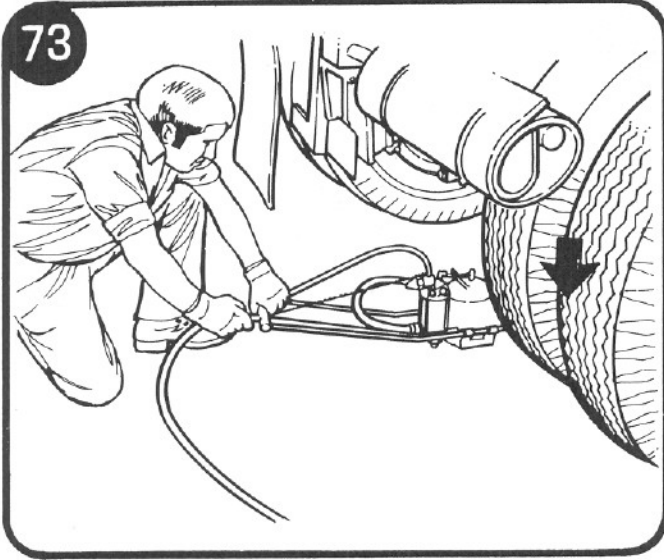

1 1/8" - 2 5/8"
 200-300 LB. FT.
 272-408 Nm
 > 2 5/8"
 250-400 LB. FT.
 339-544 Nm

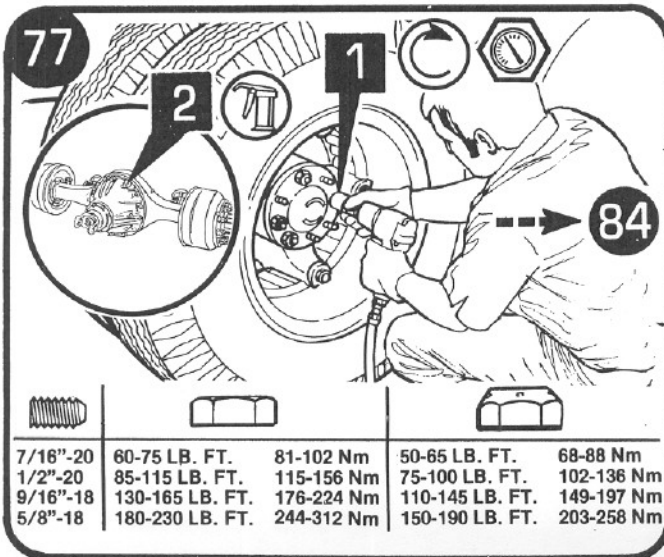
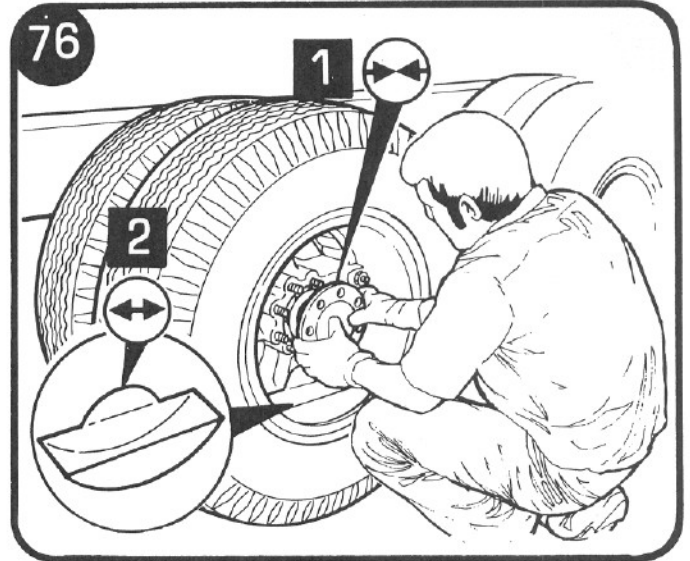
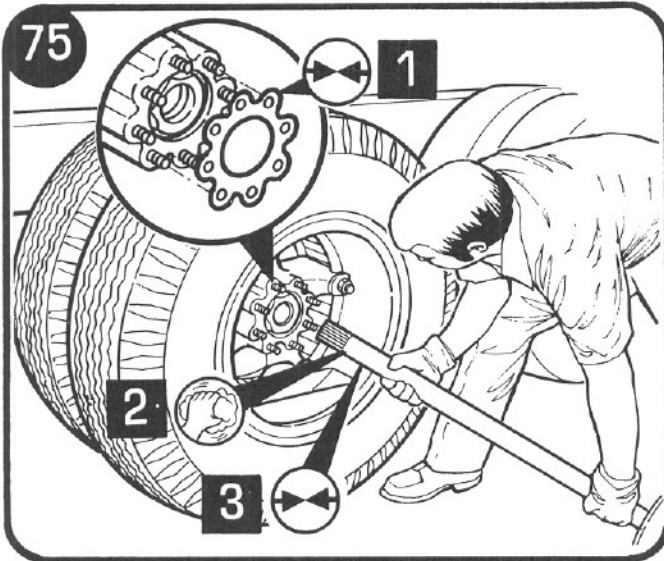

| | | | | |
|----------|-----------------|------------|-----------------|------------|
| | | | | |
| 7/16"-20 | 60-75 LB. FT. | 81-102 Nm | 50-65 LB. FT. | 68-88 Nm |
| 1/2"-20 | 85-115 LB. FT. | 115-156 Nm | 75-100 LB. FT. | 102-136 Nm |
| 9/16"-18 | 130-165 LB. FT. | 176-224 Nm | 110-145 LB. FT. | 149-197 Nm |
| 5/8"-18 | 180-230 LB. FT. | 244-312 Nm | 150-190 LB. FT. | 203-258 Nm |

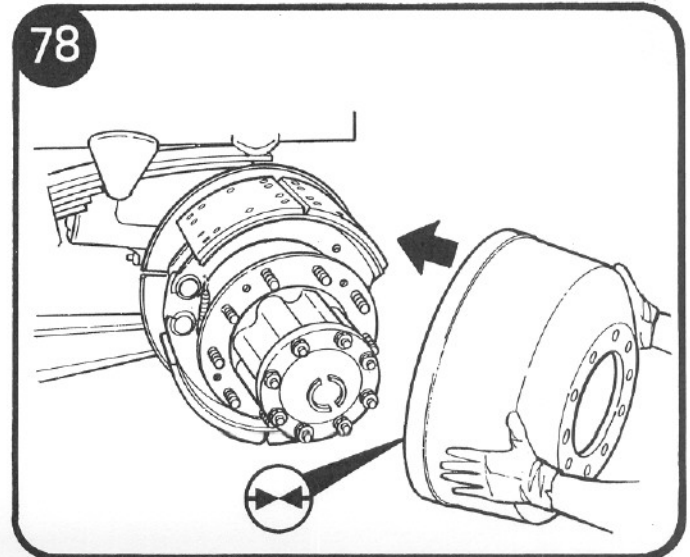

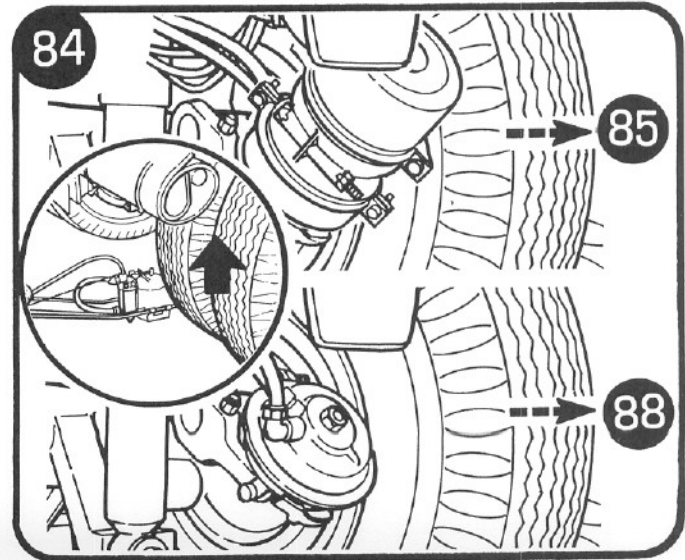
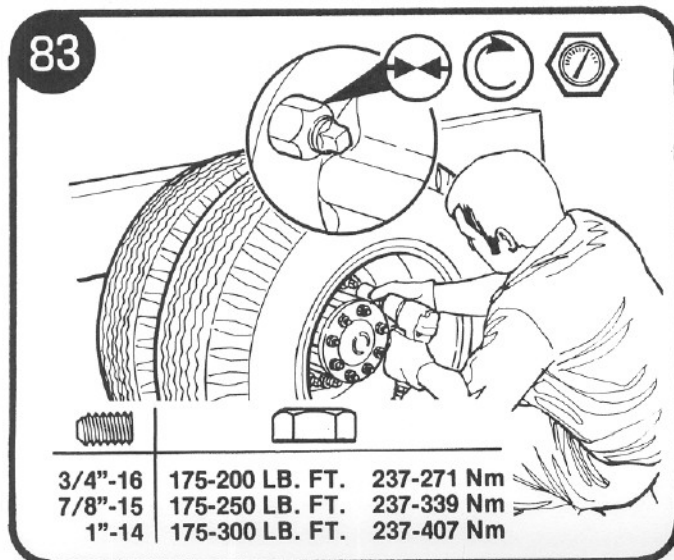
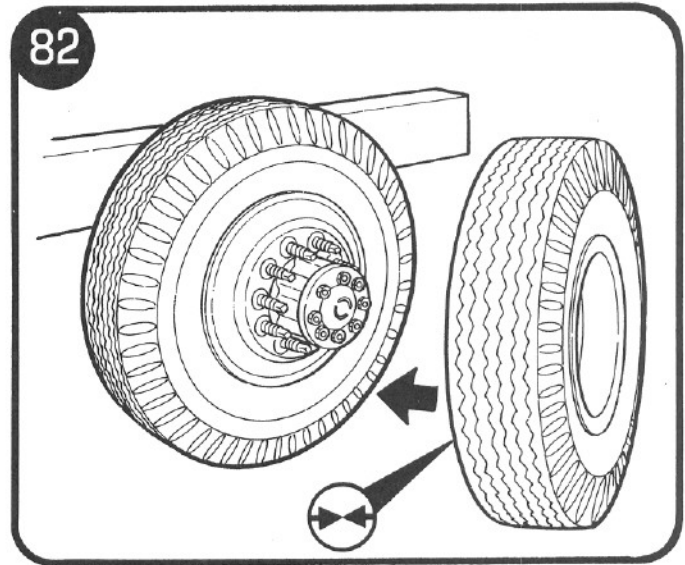
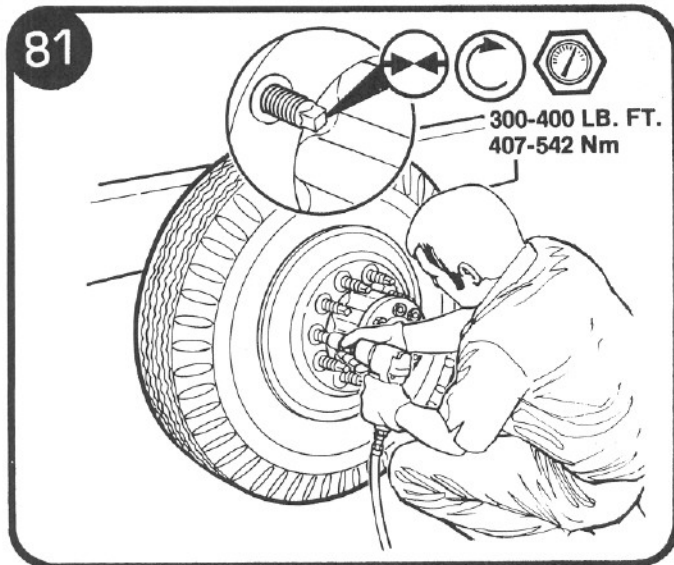
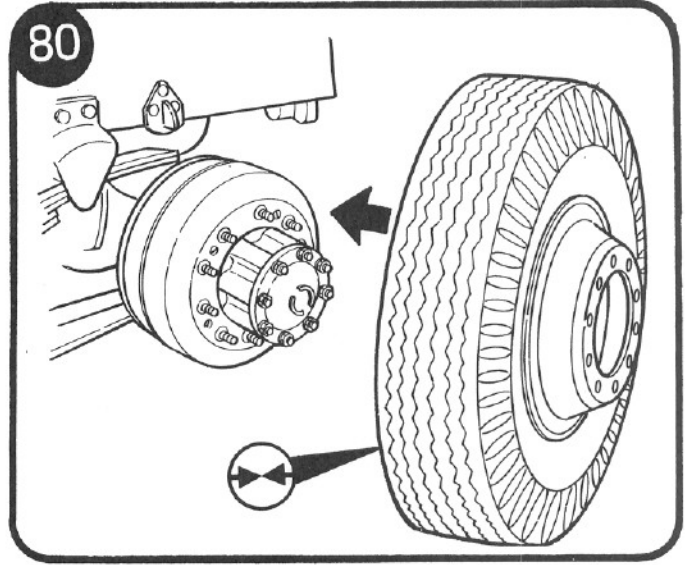
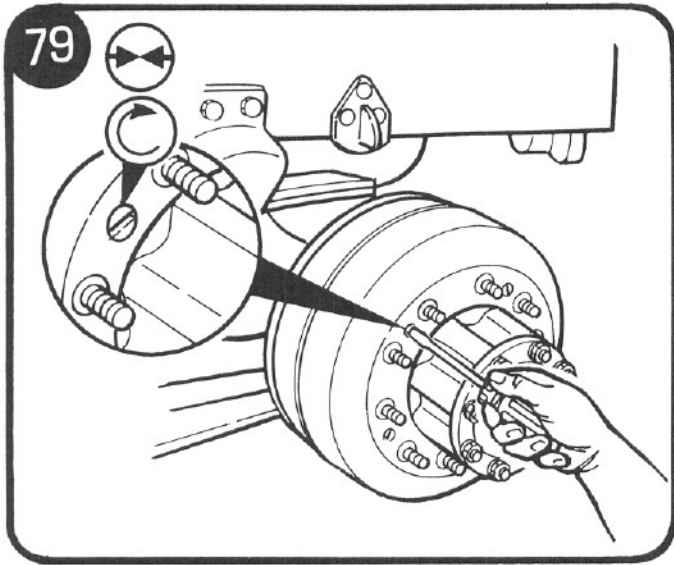

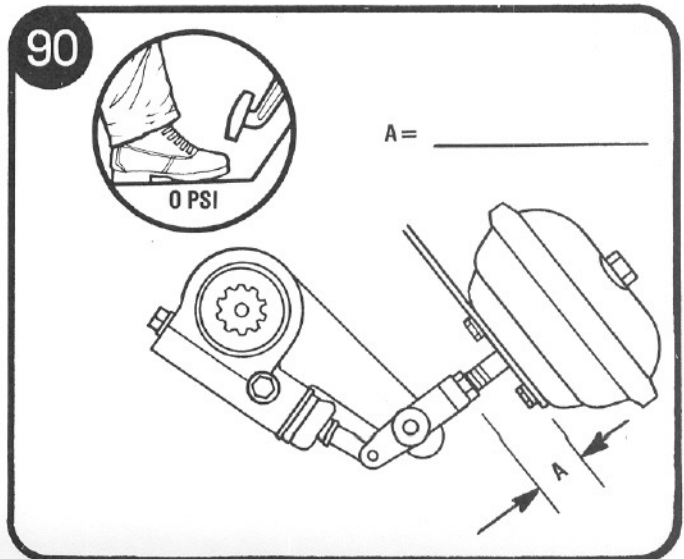
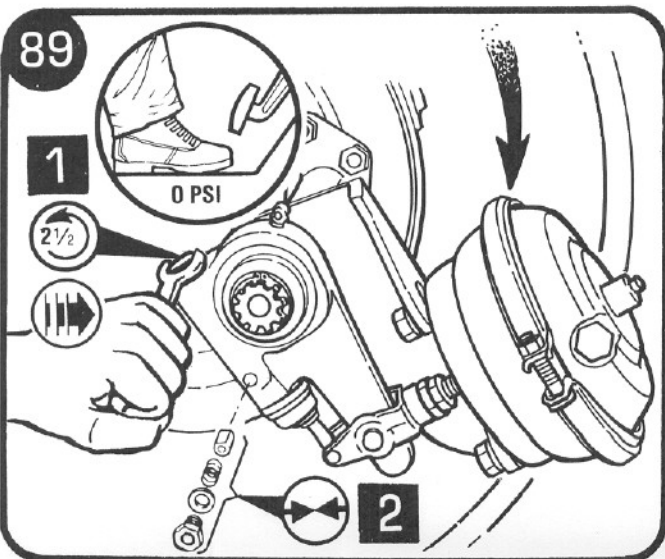
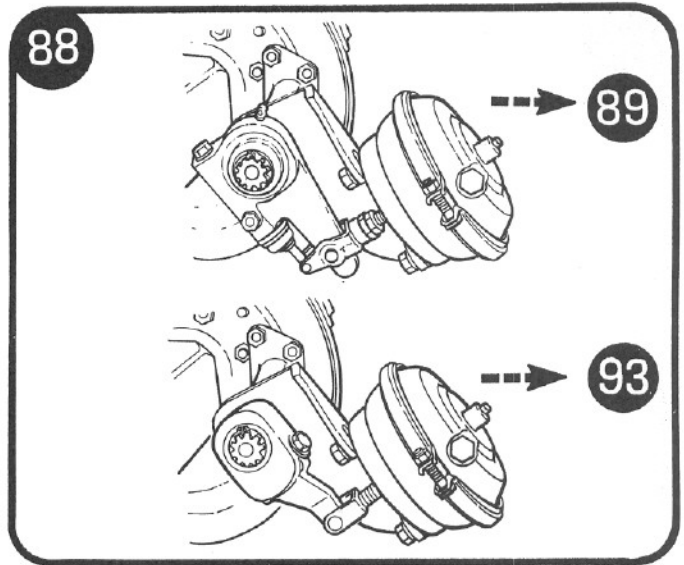
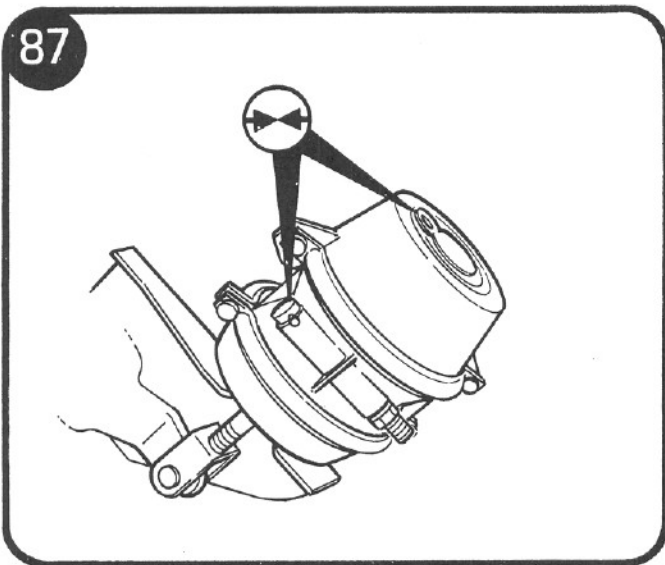
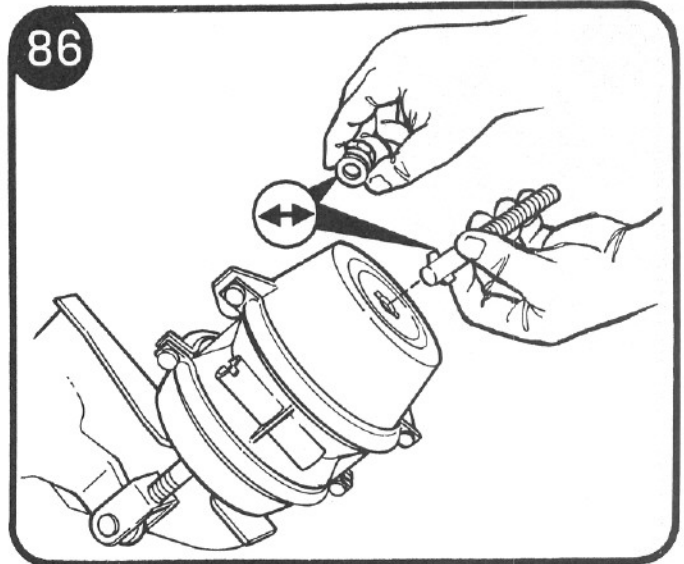
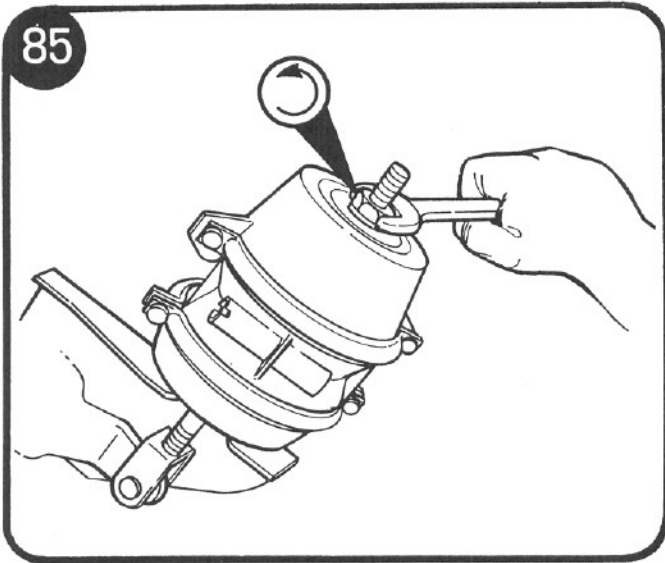



91



B = _____

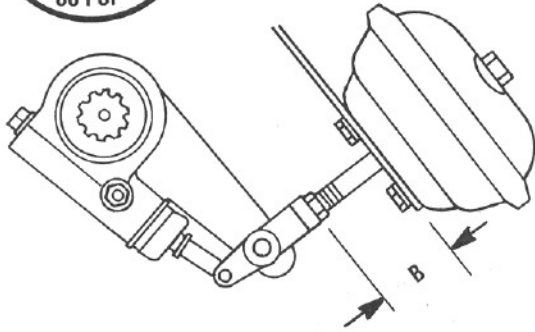

92

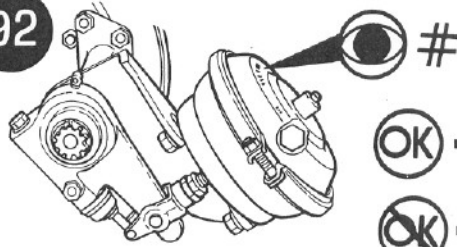

| # | B - A = |
|----|-----------------------|
| 9 | < 3.81 cm (1 1/2 in.) |
| 12 | < 3.81 cm (1 1/2 in.) |
| 16 | < 4.45 cm (1 3/4 in.) |
| 20 | < 4.45 cm (1 3/4 in.) |
| 24 | < 4.45 cm (1 3/4 in.) |
| 30 | < 5.08 cm (2 in.) |
| 36 | < 6.35 cm (2 1/2 in.) |

93

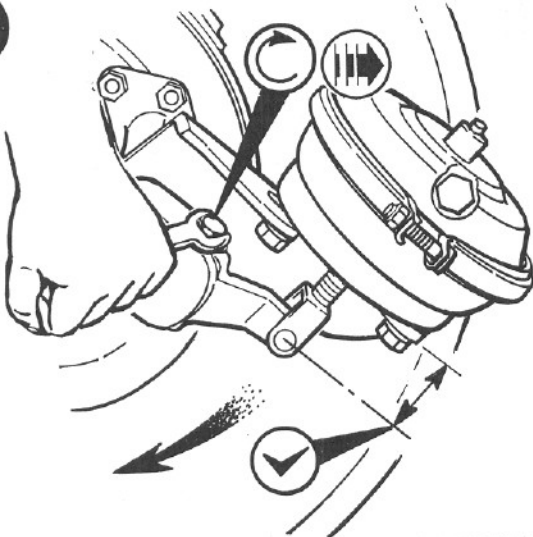

94



A = _____

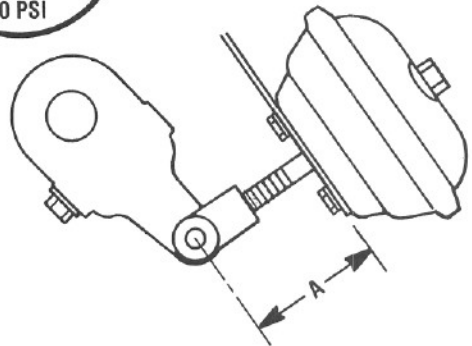

95



B = _____

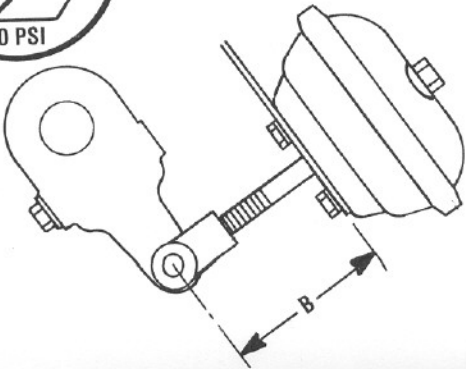

96

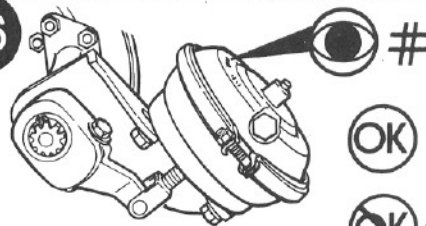

| # | B - A = |
|----|-----------------------|
| 9 | < 3.81 cm (1 1/2 in.) |
| 12 | < 3.81 cm (1 1/2 in.) |
| 16 | < 4.45 cm (1 3/4 in.) |
| 20 | < 4.45 cm (1 3/4 in.) |
| 24 | < 4.45 cm (1 3/4 in.) |
| 30 | < 5.08 cm (2 in.) |
| 36 | < 6.35 cm (2 1/2 in.) |



Rockwell International

Automotive Operations
Communications
2135 West Maple Road
Troy, Michigan 48084 U.S.A.

Technical Service Aid

Heavy Vehicles Components Operations, Rockwell International Corporation, 2135 West Maple Road, Troy, Michigan 48084, U.S.A.

SUBJECT: NEW DESIGN SHOE ROLLER RETAINER SPRING (CLIP) MODELS: ALL "Q" SERIES CAM-MASTER® BRAKES

A new design shoe roller retainer spring Part No. 3105-B-210 has been released for all new "Q" series Cam-Master brakes. The new retainer replaces original designs, Part No. 3105-R-200 and 3105-L-194.

The new shoe roller retainer spring must be in position at all times, when installing new "Q" series brakes or relining existing "Q" series brakes, to retain rollers on the brake shoe webs and to ensure proper brake operation.

INSTALLATION

- A. Seat the roller journals in the retainer loops. (Figure 1)

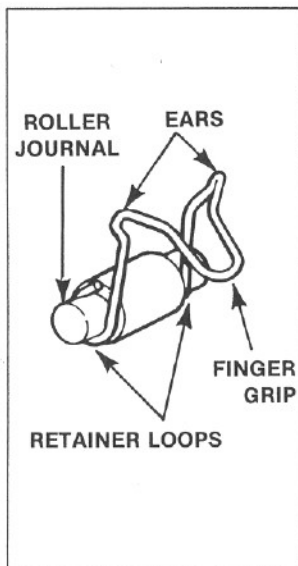

FIGURE 1

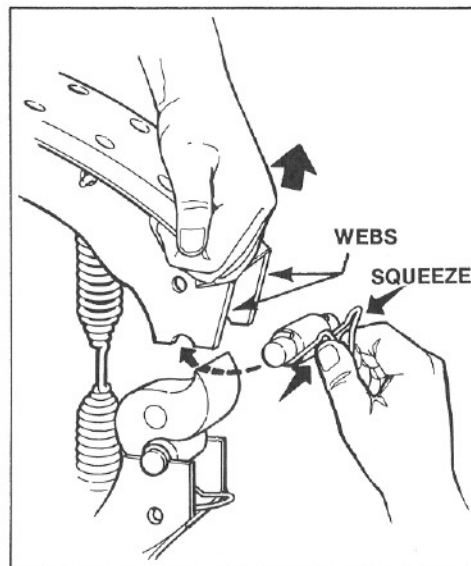

FIGURE 2

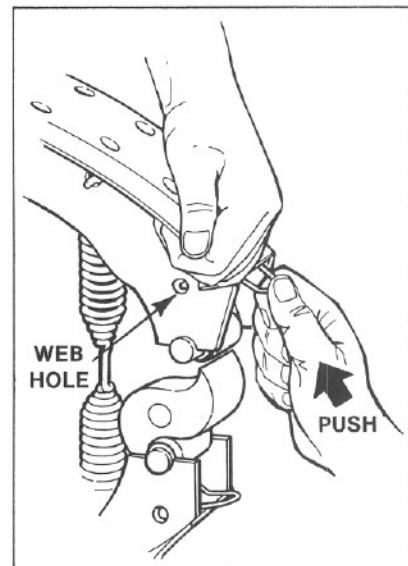

FIGURE 3

- B. Pull the brake shoe assembly away from the cam to allow enough space to install roller and retainer. While holding the shoe in this position, place the roller over the cam and seat journals into half round holes in the brake shoe webs. Squeeze the retainer enough to allow ears to fit between brake shoe webs. (Figure 2)
- C. Continue by pushing the retainer inward until ears engage holes in shoe webs. (Figure 3) After the roller and retainer assembly is installed relieve pressure on the brake shoe and allow roller to seat against cam.
- D. Repeat the above procedures for second roller.

REMOVAL

- A. Pull the brake shoe assembly away from the cam to allow enough space for roller and retainer removal.

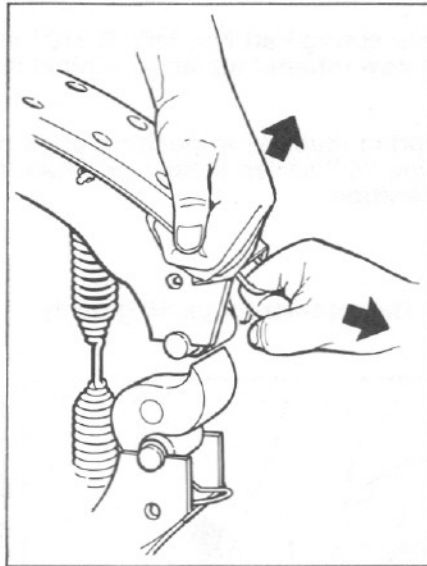

FIGURE 4

- B. While holding the shoe in this position, pull the retainer and roller from between the shoe webs using the finger grip. (Figure 4) Relieve pressure on brake shoe and allow webs to seat against cam.
- C. Repeat the above procedures for second roller.



Rockwell International

...where science gets down to business