

WM388U1C3D THROTTLE CONTROL			WM388U1C3D THROTTLE CONTROL				
ITEM	DESCRIPTION	PART NUMBER	QTY.	ITEM	DESCRIPTION	PART NUMBER	QTY.
1	Cover	119669	1	20	Needle Bearing	118111	1
2	Lever	118198	1	21	Spring	117883	1
3	Boot	103214	1	22	Rod End	117855	1
5	Screw	119668	8	23	Screw	114836	1
6	Pin	118108	1	24	Lock Nut	114592	1
7	Pin	118109	1	25	Pin	118114	2
8	Needle Bearing	118112	2	26	Fast Idle Piston	119670	1
9	O-Ring	116304	4	27	O-Ring	116331	1
10	Rod End	118506	1	28	Fast Idle Body	119671	1
11	Screw	118508	1	29	Spring	101631	1
12	Wear Ring	117401	1	30	Spring Cap	101700	1
13	U-Cup	117430	1	31	Hex Nut	114535	1
14	O-Ring	117455	1	32	Screw	114683	1
15	Body	118597	1	33	O-Ring	116318	2
16	Piston	118598	1	34	Filter	11C936	1
17	Spring	117885	1	35	Retaining Ring	116191	1
18	Shell	117368	1	36	Screen	116456	1
19	Washer	117853	4	37	Bracket	105181	1

**B. CLEANING, LUBRICATION AND REPAIR:** Use Repair Kit 130203 to service WM388U1C3D.

1. Disconnect the control cylinder and remove it from the engine.
2. Remove screws (item 5) and cover (item 1). Disassemble internal parts. Clean metal parts in petroleum base solvent (Do not immerse lever assembly in solvent). Check parts for wear, corrosion and damage, and replace as needed.
3. Coat O-ring (item 14), U-cup (item 13), inside of cylinder shell (item 18), O-ring (item 27), O-ring (item 33) and inside of body (item 28) with medium consistency silicone type lubricant (Dow Corning 33 Medium is recommended.)
4. Place U-cup and piston ring (item 12) on piston (item 16). Slide piston into cylinder shell. Insert cap screw (item 11) through piston and install piston sleeve (item 4) and springs (items 17 and 21). Install this assembly in the body. Tighten cap screw into rod end (item 10) to 120/140 in.-lbs. (13,2/15,4 ntn-m).
5. Install O-ring (item 14) in body cavity.
6. Install screen (item 36), filter (item 34) and retaining ring (item 35) in body (item 28).
7. Place O-rings (item 27 and 33) on piston (item 26) and place assembly in body.
8. Place fast idle body assembly in proper orientation on throttle cylinder. Add spring (item 29), spring retainer (item 30) and cover (item 1) to assembly, Install screws (item 5) and tighten to 28/34 in.-lbs. (3,08/3,74 ntn-m) torque.

9. NOTE: Readjustment of screw and nut (item 31 and 32) should not be necessary if they were not disturbed.
10. Replace the dust boot, making sure that the boot is securely seated in its grooves. If the dust boot has a vent, the vent must be oriented toward the mounting base of the cylinder.
11. Install the control cylinder, making sure that the external Spring is properly repositioned.
12. THE AIR THROTTLE SYSTEM MUST BE TESTED AFTER CLEANING AND/OR REPAIR. SEE PART C OF THIS BULLETIN.

**C. TESTING THE AIR THROTTLE SYSTEM**

1. With no air in the fast idle supply system, the throttle lever shall be in its fast idle position (as previously adjusted, if undisturbed). With supply air fully applied (as previously adjusted, if undisturbed) the lever shall be at normal idle position ("full off").
2. Fully apply the WM388's control valve. The engine's throttle lever should promptly go to the full throttle position. When the control valve is released, the throttle lever should immediately return to the idle position.
3. Make sure the WM388's piston moves smoothly with no evidence of binding or sticking.
4. Apply a soap solution to all joints and connections and pressurize the cylinder to 60 PSI (413,2 kPa). Maximum allowable leakage is indicated by the formation of a half-spherical soap bubble with a one inch diameter in not less than 5 seconds. If leakage is in excess of this amount, review the bulletin, making sure that the unit is assembled correctly and all connections are secure.

### INSTALLATION INSTRUCTIONS

#### WM388U1C3D AIR THROTTLE CYLINDER WITH FAST IDLE

The WM388U1C3D throttle control cylinder is used in an air throttle system to regulate the position of an engine's fuel pump lever in response to a remote signal from an operator-controlled pneumatic accelerator. In addition, the WM388U1C3D positions the fuel pump lever at fast idle when supply pressure is insufficient for normal operation of the system. This allows the engine to be warmed while the air system is being charged.

#### SPECIFICATIONS CHART

MODEL	INTERNAL SPRING FORCES		EXTERNAL SPRING FORCES (Customer must supply external spring.)		EFFECTIVE PISTON AREA
	W/PISTON FULLY RETRACTED	W/PISTON FULLY EXTENDED	W/PISTON FULLY RETRACTED	W/PISTON FULLY EXTENDED	
WM388U1C3D	10 lbs.	100 lbs.	10 lbs.	72 lbs.	3.14 in. <sup>2</sup>

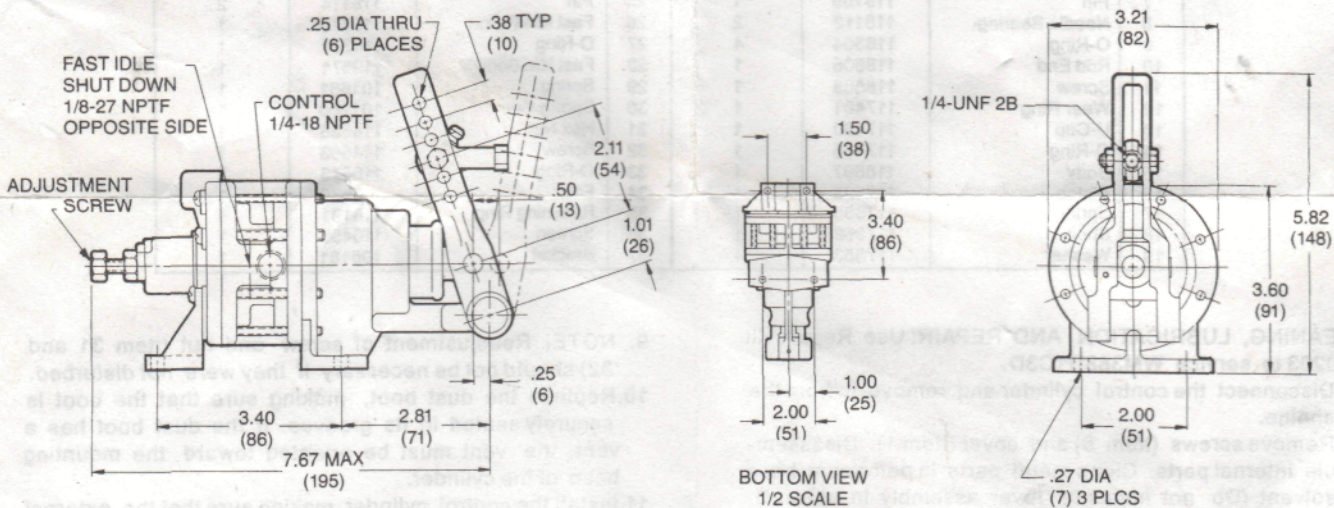

#### A. INSTALLATION REQUIREMENTS FOR FMVSS-124 APPLICATIONS: FAILURE TO INSTALL, INSPECT AND MAINTAIN THE WM388U1C3D AS DESCRIBED IN THIS BULLETIN MAY RESULT IN MALFUNCTION OF THE THROTTLE SYSTEM OR NON-COMPLIANCE WITH FMVSS-124.

1. The WM388U1C3D must be controlled by a Williams accelerator which also complies with FMVSS-124.
2. The customer must supply an external spring which exerts a resultant force on the WM388U1C3D piston Rod's centerline sufficient to retract the piston in the event of internal spring failure. Force requirements for this external spring are given in the specifications chart.
3. The torque required to return the governor shaft to idle must not exceed 2 in.-lbs. (0.22 ntm) throughout an ambient temperature range of 40° to 125°F (-40° to 52°C), regardless of whether or not the engine is running.

4. Use a pressure protection valve at the head of the air throttle circuit. WM778A is recommended.
5. Use a maximum of 40 feet of 1/4" I.D. air hose to connect the accelerator's outlet port to the WM388U1C3D's control port. Williams recommends Weatherhead H-9 hose with 00904B series 11/64" I.D. hose ends. Connect the 1/8" fast idle shutdown port to the supply line of the accelerator.
6. To adjust fast idle speed, all air must be removed from the fast idle shutdown port. (Plug supply line if necessary.) With engine running (cold engine), turn adjusting screw inward until desired fast idle speed is achieved. Maximum adjustment is approximately 25% of linear throttle lever travel.
7. Make sure that when full supply pressure is available at the fast idle shutdown port, the throttle lever returns to normal idle position ("full off").
8. Make sure that the WM388U1C3D operates smoothly with no evidence of sticking or binding.