









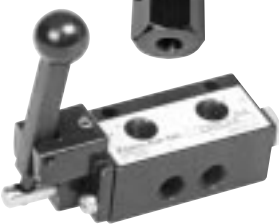

Port Size	Flow Rate/ Factor	Function	Series	Actuators	Page Number
10-32 & 1/8 NPT Modular	Cv = 0.05 to Cv = 0.23	2 Way 3 Way 4 Way, 2 Position	Modular Manifold	Solenoid	11.3 - 11.4
1/8 NPT & 1/4 NPT	Cv = 0.05 to Cv = 0.23	2 Way 3 Way	Hex Body	Solenoid	11.5–11.6
1/8 NPT	Cv = 0.27	2 Way 3 Way 4 Way, 2 Position	18	Manual Mechanical Pilot Solenoid	11.7-11.8 11.7-11.8 11.7-11.8 11.9-11.12
1/4 NPT	Cv = 1.0	3 Way 4 Way, 2 Position 4 Way, 3 Position	14	Manual Mechanical Pilot Solenoid	11.13-11.16 11.13-11.14 11.13-11.15 11.17-11.22
1/4 NPT Stacking	Cv = 1.0	3 Way 4 Way, 2 Position	M14	Manual Mechanical Pilot Solenoid	11.13 11.13 11.13 11.20
3/8 NPT	Cv = 1.0	3 Way 4 Way, 2 Position 4 Way, 3 Position	34	Manual Mechanical Pilot Solenoid	11.13-11.16 11.13-11.14 11.13-11.15 11.17-11.22
3/8 NPT & 1/2 NPT Manifold	Cv = 2.2 to Cv = 3.9	3 Way 4 Way, 2 Position 4 Way, 3 Position	12A	Manual Pilot Solenoid	11.23-11.28
3/8 NPT	Cv = 2.4 to Cv = 4.1	3 Way 4 Way, 2 Position 4 Way, 3 Position	38	Manual Pilot Solenoid	11.23–11.28
1/2 NPT	Cv = 2.4 to Cv = 4.1	3 Way 4 Way, 2 Position 4 Way, 3 Position	12	Manual Pilot Solenoid	11.23–11.28
1/2 NPT High Flow	Cv = 6.2	3 Way 4 Way, 2 Position	12B	Manual Pilot Solenoid	11.23–11.28

	<i>Series</i>	<i>Quick Page No.</i>
	Modular Manifold	11.3
	Hex Body	11.5
	18	11.7
	14	11.13
	M14	11.13
	34	11.13
	12A	11.23
	38	11.23
	12	11.23
	12B	11.23

Miniature 53 STYLE Solenoid Valves 2, 3 or 4 Way - Modular Manifolding 2, 3 or 4 Way - Single Mounting



Time Proven • Space Saving • Reliable • 2, 3 and 4 Way Solenoid Valves with 10-32 or 1/8 NPT ports are available in singular or modular manifold versions. Any combination of function and ports can be combined in the same manifold stack to save time, space and plumbing. With pressure manifold plugging, two or more pressure ranges and/or medias can be controlled in the same stack.

For Each Valve Specify:

	EXAMPLE	
Basic Model Number	103-M	See Chart Below
Letter for Housing	-C	C Conduit, G Grommet, F DIN
Number for Seat	-1	See orifice information chart below
Options		See option Information below
Volts & Hertz	120/60	See solenoid information Page 11.29

Example: 3 Way modular mounting with manifold inlet, 1/8 NPT inlet, 10-32 Cylinder Port, Conduit Housing, 3/64 Seat, 120 Volts/60 HZ.
Model Number = 103-M-C-1, 120/60

For Complete Assembled Banks Specify:

- Quantity of assembled Banks
 - Valve models (start left to right, see photo above)
 - Mounting brackets, if desired #101
- Example... Using the photo above
1 Bank consisting of:
- | | | |
|---|-----------------------------|--------|
| 1 | 113-M-C-1 | 120/60 |
| 1 | 103-M-F-1 | 120/60 |
| 1 | 104-M-G-1 | 120/60 |
| 1 | 114-M-C-1 | 120/60 |
| 1 | Pair #101 Mounting Brackets | |

	Function	Inlet Port	Cylinder Port	Basic Model No.
Valves for Individual Mounting & Individual Inlet	2 Way N.C.	1/8 NPT	1/8 NPT	112-S
	3 Way N.C.	1/8 NPT	1/8 NPT	113-S
	4 Way	10-32	10-32	104-S-10
	4 Way	1/8 NPT	10-32	104-S-18
Valves for Modular Mounting & Individual Inlet	2 Way N.C.	10-32	10-32	102-SM
	3 Way N.C.	10-32	10-32	103-SM
Valves for Modular Mounting & Inlet (Pressure Manifoldd)	2 Way N.C.	1/8 NPT	10-32	102-M
	2 Way N.C.	1/8 NPT	1/8 NPT	112-M
	3 Way N.C.	1/8 NPT	10-32	103-M
	3 Way N.C.	1/8 NPT	1/8 NPT	113-M
	4 Way	1/8 NPT	10-32	104-M
	4 Way	1/8 NPT	1/8 NPT	114-M

All Mountings 3 Way Normally Open use 4 Way & Plug N.C. port

Operating Pressures

Applies to all 4 Way 104 and 114 series valves.
See **Orifice Information** below for pressure ranges of 2 & 3 Way valves.

STANDARD SPRING

- 40 psi Minimum
 - 150 psi Maximum with #1, 3/64 orifice.
- See **Orifice Information** below for Maximum with other orifices.

OPTIONAL LOW PRESSURE SPRING

- 20 psi:
- 20 psi Minimum
- 25 psi Maximum
- 25 psi:
- 25 psi Minimum
- 60 psi Maximum

OPTION INFORMATION

- Viton Seals for media compatibility specify Option -V
- Coils & Housing, See page 11.29.
- Low Pressure Spring - 4 Way Only - See Operating Pressures.
- Pro-Coat™ (Electroless Nickel Plate) Option -N, See page 1.10.
- Special Bank Assembly (Plugs, Fittings, Wire Terminals) See Pg iii.
- Normally Open (N.O.) 2 & 3 Way Valves - Use 4 Way Valve & Plug N.C. Port.

Accessories

- Mounting Brackets Part # 101.
- Connectors for Mini-DIN "F", See page 11.30.
- SM-10 Muffler, See page 14.1.

ORIFICE INFORMATION

Available Orifices and Equivalent Maximum Pressure Ratings for AC Voltages (DC Ratings Slightly Lower)

	Cv Factor	2 Way N.C.	3 Way N.C.	4 Way	CFM – Flow @		
					100 psi	50 psi	
Number 0	1/32	.022	500 psi	200 psi	150 psi	1.3	0.9
Number 1	3/64	.055	400	150	150	3.5	2.0
Number 2	1/16	.075	200	100	100	5.8	3.4
Number 3	3/32	.156	100	60	80	9.0	6.0
Number 4	1/8	.230	75	30	Not Available	Not Available	8.0

MODELS 102-M, 103-M, 104-M, 112-M, 113-M & 114-M

Supply pressure can be connected to either or both ends of the stack. Due to the fact that the supply pressure port on all "M" valve bodies is tapped on both sides, the pressure manifold can be plugged at any point within the stack. This allows you to supply the stack with two different pressures or media, one from each end.

For more than two inputs a port block can be provided in midstack. Spacers can be included for applications requiring the larger EXPLOSION PROOF operator. Contact Fabco-Air with your specific requirements.

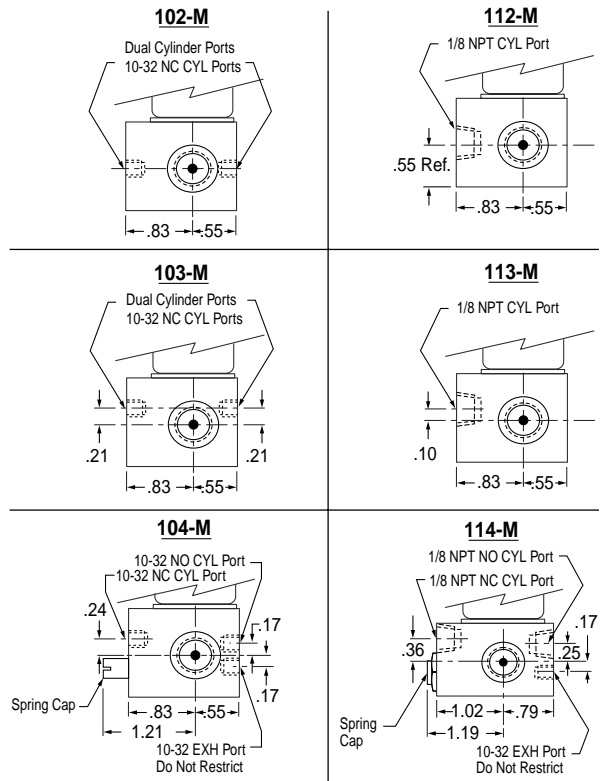
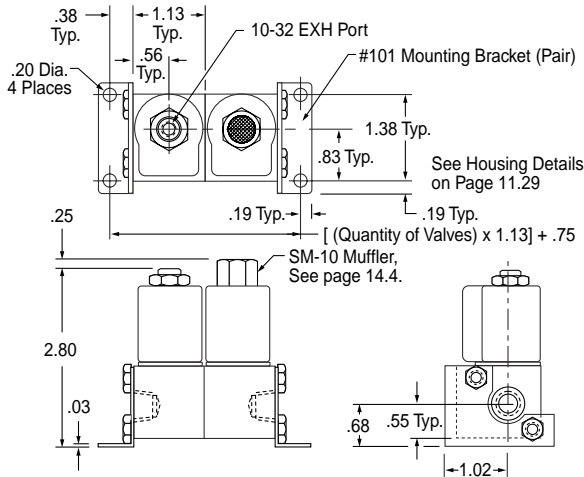

MODEL 104-S-10 (10-32 Inlet Port) MODEL 104-S-8 (1/8 NPT Inlet Port)

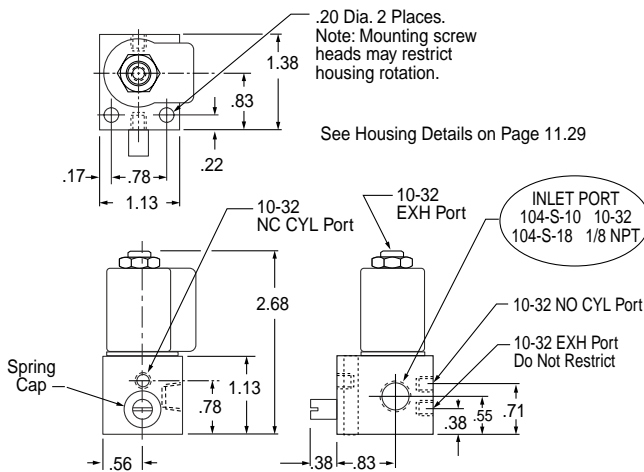

MODEL 112-S (2-Way), 113-S (3-Way)

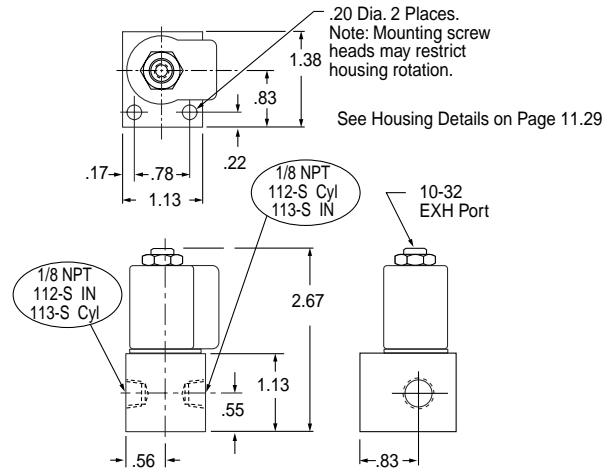

MODEL 114-S

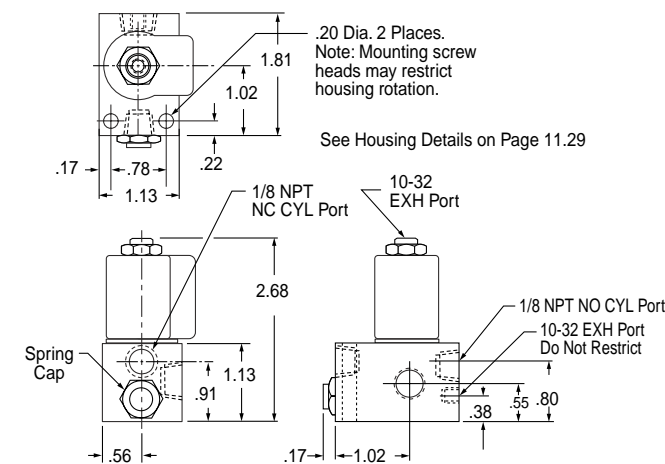

MODEL 102-SM (2-Way), 103-SM (3-Way)

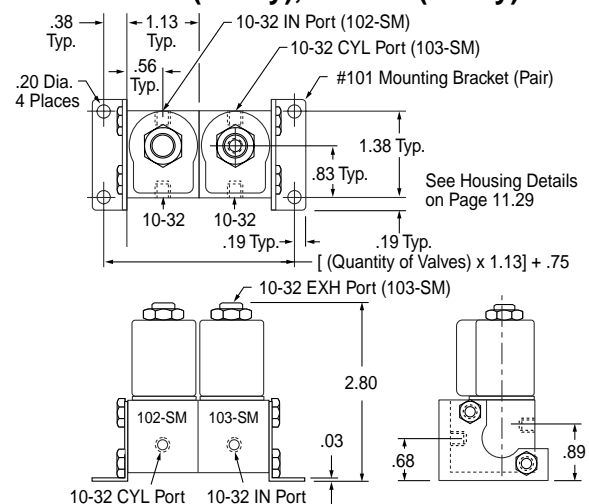

Hex Body 53 STYLE Solenoid Valves

- **Body** Hex aluminum, black anodized - 3 Different porting styles.
- **Media** Air, water & other fluids compatible with standard Buna-N seals and aluminum.
- **Power** See page 11.29

- **Operating Temperature:**
0°F (-18°C) to +104°F (40°C) ambient.
0°F (-18°C) to +150°F (65°C) media.
- **Voltages** See page 11.29
- **Operating Pressure** See chart with orifice information
- **Internal Parts** Stainless Steel

2 WAY NORMALLY OPEN

BODY STYLE 1		SIDE PORT		Basic Model
De-Energized	Energized	IN	OUT	
		10-32	1/8	82-★-◆-NO1
		1/8	1/8	82-★-◆-NO2
		10-32	1/4	42-★-◆-NO1
		1/8	1/4	42-★-◆-NO2

BODY STYLE 2 FEMALE BOTTOM PORT

BODY STYLE 2		FEMALE BOTTOM PORT		Basic Model
De-Energized	Energized	IN	OUT	
		10-32	1/8	F-82-★-◆-NO1
		1/8	1/8	F-82-★-◆-NO2
		10-32	1/4	F-42-★-◆-NO1
		1/8	1/4	F-42-★-◆-NO2

BODY STYLE 2 FEMALE BOTTOM PORT

BODY STYLE 2		FEMALE BOTTOM PORT		Basic Model
De-Energized	Energized	IN	OUT	
		1/8	10-32	FX-82-★-◆-NO1
		1/8	1/8	FX-82-★-◆-NO2
		1/4	10-32	FX-42-★-◆-NO1
		1/4	1/8	FX-42-★-◆-NO2

BODY STYLE 3 MALE BOTTOM PORT

BODY STYLE 3		MALE BOTTOM PORT		Basic Model
De-Energized	Energized	IN	OUT	
		10-32	1/8	082-★-◆-NO1
		1/8	1/8	082-★-◆-NO2
		10-32	1/4	042-★-◆-NO1
		1/8	1/4	042-★-◆-NO2

BODY STYLE 3 MALE BOTTOM PORT

BODY STYLE 3		MALE BOTTOM PORT		Basic Model
De-Energized	Energized	IN	OUT	
		1/8	10-32	X-82-★-◆-NO1
		1/8	1/8	X-82-★-◆-NO2
		1/4	10-32	X-42-★-◆-NO1
		1/4	1/8	X-42-★-◆-NO2

2 WAY NORMALLY CLOSED

BODY STYLE 1		SIDE PORTS		Basic Model
De-Energized	Energized	IN	OUT	
		1/8	1/8	82-★-◆
		1/4	1/4	42-★-◆

BODY STYLE 2 FEMALE BOTTOM PORT

BODY STYLE 2		FEMALE BOTTOM PORT		Basic Model
De-Energized	Energized	IN	OUT	
		1/8	1/8	F-882-★-◆
		1/8	1/4	F-842-★-◆
		1/4	1/8	F-482-★-◆
		1/4	1/4	F-442-★-◆

BODY STYLE 2 FEMALE BOTTOM PORT

BODY STYLE 2		FEMALE BOTTOM PORT		Basic Model
De-Energized	Energized	IN	OUT	
		1/8	1/8	FX-882-★-◆
		1/8	1/4	FX-482-★-◆
		1/4	1/8	FX-842-★-◆
		1/4	1/4	FX-442-★-◆

BODY STYLE 3 MALE BOTTOM PORT

BODY STYLE 3		MALE BOTTOM PORT		Basic Model
De-Energized	Energized	IN	OUT	
		1/8	1/8	882-★-◆
		1/8	1/4	842-★-◆
		1/4	1/8	482-★-◆
		1/4	1/4	442-★-◆

BODY STYLE 3 MALE BOTTOM PORT

BODY STYLE 3		MALE BOTTOM PORT		Basic Model
De-Energized	Energized	IN	OUT	
		1/8	1/8	X-882-★-◆
		1/8	1/4	X-482-★-◆
		1/4	1/8	X-842-★-◆
		1/4	1/4	X-442-★-◆

11

HOW TO ORDER

Basic Model Number	EXAMPLE	
Insert Letter for Housing at ★	X883	See Model Charts
Number for Orifice at ◆	-C	C Conduit, G Grommet, F DIN See Solenoid Information Page 11.29
All 3 Way EX Orifices are 1/16	-1	See Chart, Orifice Information
Options		See Chart, Option Information
Volts & Hertz	120/60	See Solenoid Information Page 11.29

Example: 3 Way N.C., 1/8 NPT Male Bottom Inlet, 1/8 NPT Side Cylinder, Conduit Housing, 3/64 Seat, 120 Volts/60 HZ.

Model Number = X883-C-1, 120/60

OPTIONS:

- 1/8 NPT Adapter (3 Way N.C. Top Exhaust) **-A** See Pg. 11.6
- Viton Seals (for media compatibility) **-V**
- Explosion Proof **-EP** See Pg. 11.30
- Pro-Coat™ (Electroless Nickel Plate) **-N** See Pg. 1.10
- Spade Electrical Connections See Pgs. 11.29 & 11.30

Specify Suffix

ACCESSORIES:

- Solenoid Exhaust Muffler **SM-10** See Page 14.4
- Connectors for Mini-DIN "F" See Pg. 11.30

Directional Control Valves

1/8 & 1/4 NPT
2 & 3 Way Valves

Hex Body

ORIFICE INFORMATION

Available Orifices and Equivalent Maximum Pressure Ratings for AC Voltages (DC Ratings Slightly Lower)

	Cv Factor	Pressure Ratings				CFM – Flow @		
		2 Way N.O.	2 Way N.C.	3 Way N.O.	3 Way N.C.	100 psi	50 psi	
Number 0	1/32	.022	150 psi	500 psi	150 psi	200 psi	1.3	0.9
Number 1	3/64	.055	125	400	125	150	3.5	2.0
Number 2	1/16	.075	100	200	100	100	5.8	3.4
Number 3	3/32	.156	NA	100	NA	60	9.0	6.0
Number 4	1/8	.230	NA	75	NA	30	NA	8.0

All 3 way (EX) exhaust orifices are 1/16.

All 3 way (EX) exhaust orifices are 1/16.

3 WAY NORMALLY OPEN

BODY STYLE 1

SIDE PORT

De-Energized	Energized	IN	CYL	EX†	Basic Model
		10-32	1/8	1/8	83-★-◆-NO1
		1/8	1/8	1/8	83-★-◆-NO2
		10-32	1/4	1/4	43-★-◆-NO1
		1/8	1/4	1/4	43-★-◆-NO2

BODY STYLE 2

FEMALE BOTTOM PORT

De-Energized	Energized	IN	CYL	EX	Basic Model
		10-32	1/8	1/8	F-883-★-◆-NO1
		1/8	1/8	1/8	F-883-★-◆-NO2
		10-32	1/8	1/4	F-483-★-◆-NO1
		1/8	1/8	1/4	F-483-★-◆-NO2
		10-32	1/4	1/8	F-843-★-◆-NO1
		1/8	1/4	1/8	F-843-★-◆-NO2
		10-32	1/4	1/4	F-443-★-◆-NO1
		1/8	1/4	1/4	F-443-★-◆-NO2

BODY STYLE 3

MALE BOTTOM PORT

De-Energized	Energized	IN	CYL	EX	Basic Model
		10-32	1/8	1/8	883-★-◆-NO1
		1/8	1/8	1/8	883-★-◆-NO2
		10-32	1/8	1/4	483-★-◆-NO1
		1/8	1/8	1/4	483-★-◆-NO2
		10-32	1/4	1/8	843-★-◆-NO1
		1/8	1/4	1/8	843-★-◆-NO2
		10-32	1/4	1/4	443-★-◆-NO1
		1/8	1/4	1/4	443-★-◆-NO2

3 WAY NORMALLY CLOSED

BODY STYLE 1

SIDE PORTS

De-Energized	Energized	IN	CYL	EX†	Basic Model
		1/8	1/8	10-32	83-★-◆
		1/4	1/4	10-32	43-★-◆

† For optional 1/8 NPT Adapter add Suffix "A"

BODY STYLE 2

FEMALE BOTTOM PORT

De-Energized	Energized	IN	CYL	EX†	Basic Model
		1/8	1/8	10-32	F-883-★-◆
		1/8	1/4	10-32	F-443-★-◆
		1/4	1/8	10-32	F-843-★-◆
		1/4	1/4	10-32	F-443-★-◆

† For optional 1/8 NPT Adapter add Suffix "A"

BODY STYLE 2

FEMALE BOTTOM PORT

De-Energized	Energized	IN	CYL	EX†	Basic Model
		1/8	1/8	10-32	FX-883-★-◆
		1/8	1/4	10-32	FX-483-★-◆
		1/4	1/8	10-32	FX-843-★-◆
		1/4	1/4	10-32	FX-443-★-◆

† For optional 1/8 NPT Adapter add Suffix "A"

BODY STYLE 3

MALE BOTTOM PORT

De-Energized	Energized	IN	CYL	EX†	Basic Model
		1/8	1/8	10-32	883-★-◆
		1/8	1/4	10-32	843-★-◆
		1/4	1/8	10-32	483-★-◆
		1/4	1/4	10-32	443-★-◆

† For optional 1/8 NPT Adapter add Suffix "A"

BODY STYLE 3

MALE BOTTOM PORT

De-Energized	Energized	IN	CYL	EX†	Basic Model
		1/8	1/8	10-32	X-883-★-◆
		1/8	1/4	10-32	X-483-★-◆
		1/4	1/8	10-32	X-843-★-◆
		1/4	1/4	10-32	X-443-★-◆

† For optional 1/8 NPT Adapter add Suffix "A"

BODY STYLE 1 – Side Ports

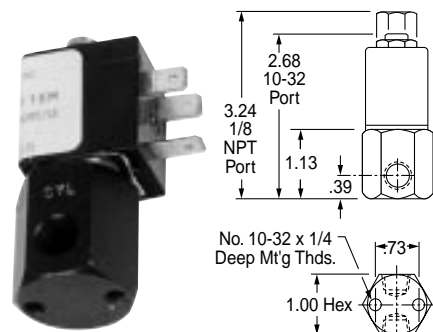

See Pg. 11.29 for Housing Details

BODY STYLE 2 – Female Bottom Port

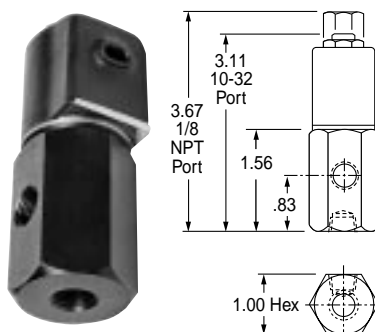

See Pg. 11.29 for Housing Details

BODY STYLE 3 – Male Bottom Port

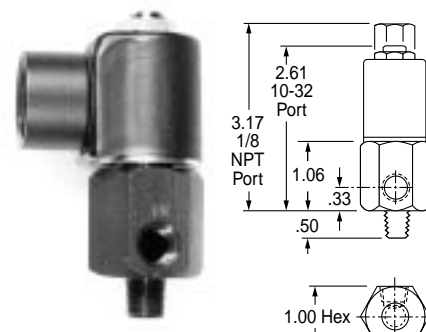

See Pg. 11.29 for Housing Details

1/8 NPT PORTED, MANUAL, MECHANICAL AND PILOT OPERATED AIR VALVES – “The Finest in Simplicity” 2, 3 and 4 Way - 2 Position – Operation to 150 psi Air

Suitable for Vacuum directional flow applications, but NOT for holding vacuum.
Short stroke of lightweight Delrin® spools provides fast, positive, and reliable response.

Note 1: Specify Normally Open by substituting -20 for -2 & -30 for -3.

Air Pilot



Standard 2 Way & 3 Way spring return are normally closed. For normally open the actuators may be exchanged end for end or by specifying -20 for -2 & -30 for -3. Minimum pilot pressure:
Standard spring 60 psi
Light spring (Option -L) . . . 40 psi
Double pilot 20 psi

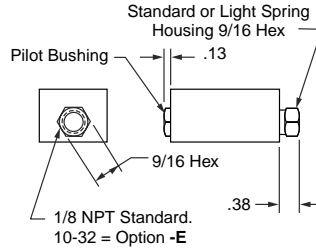

2 Way	3 Way	4 Way
Single Pilot - Spring Return		
18SP-2	18SP-3	18SP-4
Double pilot		
18DP-2	18DP-3	18DP-4
Replacement spool & seals		
1800-902	1800-903	1800-904
Light spring, Option -L 10-32 pilot port, Option -E		

Air Pilot Amplifier



1" Delrin piston in aluminum housing meets low pressure requirements. Standard 2 Way & 3 Way spring return are normally closed. For normally open the actuators may be exchanged end for end or by specifying -20 for -2 & -30 for -3. Minimum pilot pressure:
Standard spring 10 psi
Light spring (Option -L) . . . 7 psi
Against 0 psi pilot 2 psi

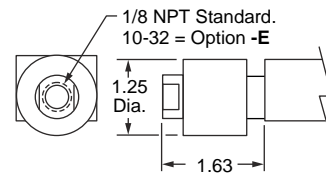

2 Way	3 Way	4 Way
Single Pilot (Amplifier) - Spring Return		
18SA-2	18SA-3	18SA-4
Double pilot - 2 amplifiers		
18DA-2	18DA-3	18DA-4
Double pilot - 1 amplifier, 1 air pilot		
18DAP-2	18DAP-3	18DAP-4
When both pilots are pressurized, the amplifier overrides.		
Replacement spool & seals		
1800-902	1800-903	1800-904
Light spring, Option -L 10-32 pilot port, Option -E		

Rod Actuator



Plated steel rod in brass bushing. Standard 2 Way & 3 Way spring return are normally closed. For normally open the actuators may be exchanged end for end or specify by substituting -20 for -2 & -30 for -3. Force to actuate:
Standard spring 6.5 lb.
Light spring (Option -L) . . . 5.0 lb.
Double Rod 1.2 lb.

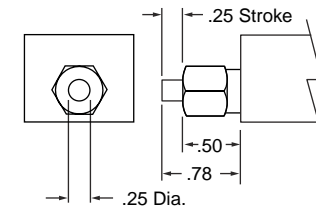

2 Way	3 Way	4 Way
Single Rod - Spring Return		
18SR-2	18SR-3	18SR-4
Single Rod- Pilot Return		
18SRP-2	18SRP-3	18SRP-4
Double rod		
18DR-2	18DR-3	18DR-4
Replacement spool & seals		
1800-902	1800-903	1800-904
Light return spring, Option -L		

Roller Cam



Case hardened steel roller and shaft in hard anodized aluminum housing. Standard 2 Way & 3 Way spring return are normally closed. For normally open specify by substituting -20 for -2 & -30 for -3. Force to actuate:
Standard spring 6.5 lb.
Light spring (Option -L) . . . 5.0 lb.
Double Cam 1.2 lb.

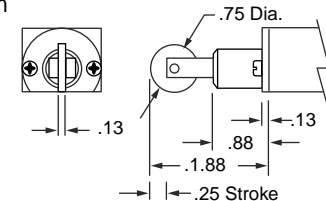

2 Way	3 Way	4 Way
Single Cam - Spring Return		
18CR-2	18CR-3	18CR-4
Single Cam - Pilot Return		
18CRP-2	18CRP-3	18CRP-4
Replacement spool & seals for above		
1800-912	1800-913	1800-914
Double cam		
18CCR-2	18CCR-3	18CCR-4
Replacement spool & seals		
1800-922	1800-923	1800-924
Light return spring, Option -L		

11

Valve Body Dimensions

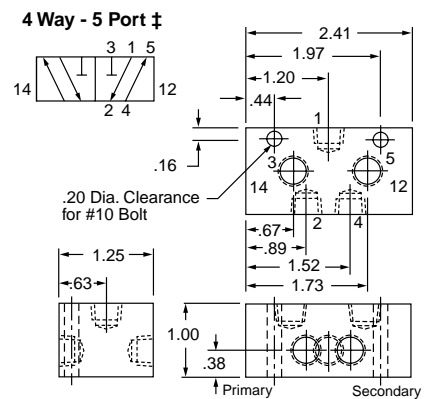
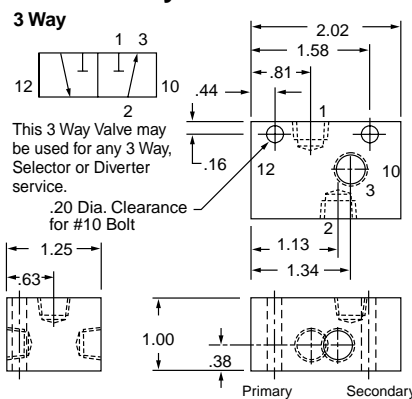
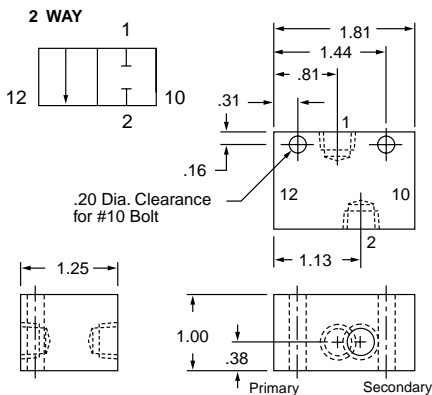

Standard 2 & 3 way spring return models are normally closed. Models with thread in actuators may be converted to normally open by exchanging actuators end for end. Other models require specification and factory assembly. See note 1.

‡ 4 way - 5 port May be used as either single inlet - dual exhaust or dual inlet - single exhaust.

- Aluminum bar body
- Anodized black
- Honed & burnished bore
- Pressure balanced spool
- Delrin spool
- Buna-N seals
- Operation to 150 psi
- 4 Way - 5 port may be used as either single inlet - dual exhaust or dual inlet - single exhaust.

FEATURES

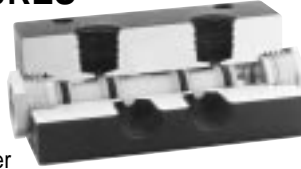

- Prelubed with Magnalube®-G Grease
- Interchangeability of Parts
- Cv = 0.27
14.2 SCFM Free Flow to Atmosphere at 80 psi Supply
- Operating temperature 0° to +180°F; Solenoid controlled models +150°F max. See pages 11.9 and 11.11.

OPTIONS

- Light spring – Specify Option -L
- Viton seals – Specify Option -V
- Spools for bleeder pilot
- Multiple stacking with or without common inlet. Consult factory.

Note 1: Specify Normally Open by substituting -20 for -2 & -30 for -3.

Small Palm Button



Un-anodized aluminum button with plated steel rod in brass bushing. Standard 2 Way & 3 Way spring return are normally closed. For normally open the actuators may be exchanged end for end or specify by substituting -20 for -2 & -30 for -3.

Force to actuate:
Standard spring 6.5 lb.
Light spring (Option -L) . . 5.0 lb.
Double Button 1.2 lb.

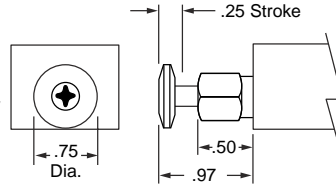

2 Way	3 Way	4 Way
Single Button - Spring Return	18PS-2	18PS-3 18PS-4
Single Button - Pilot Return	18PSP-2	18PSP-3 18PSP-4
Double Button	18PPS-2	18PPS-3 18PPS-4
Replacement spool & seals	1800-902	1800-903 1800-904
Light spring Option -L		

Large Palm Button



Red anodized aluminum button with plated steel rod in brass bushing. Standard 2 Way & 3 Way spring return are normally closed. For normally open the actuators may be exchanged end for end or specify by substituting -20 for -2 & -30 for -3.

Force to actuate:
Standard spring 6.5 lb.
Light spring (Option -L) . . 5.0 lb.
Double Button 1.2 lb.

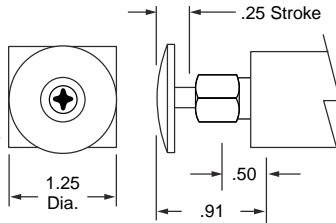

2 Way	3 Way	4 Way
Single Button - Spring Return	18PL-2	18PL-3 18PL-4
Single Button - Pilot Return	18PLP-2	18PLP-3 18PLP-4
Double Button	18PPL-2	18PPL-3 18PPL-4
Replacement spool & seals	1800-902	1800-903 1800-904
Light spring Option -L		

Panel Mount Button



Phenolic button with plated steel rod in brass bushing; **black** button standard, **red** button Option -R. Standard 2 Way and 3 Way assemblies are normally closed with knob in the "out" position. For normally open specify by substituting -20 for -2 and -30 for -3.

Force to actuate:
Standard spring 6.5 lb.
Light spring (Option -L) . . 5.0 lb.
Double Button 1.2 lb.
Detented 3.0 lb.

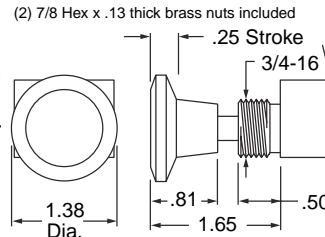

2 Way	3 Way	4 Way
Spring Return	18PMS-2	18PMS-3 18PMS-4
Pilot Return	18PMP-2	18PMP-3 18PMP-4
Replacement spool & seals for above.	1800-902	1800-903 1800-904
Detented (Push Pull)	18PMD-2	18PMD-3 18PMD-4
Replacement spool & seals	1800-942†	1800-943† 1800-944†
Light spring Option -L		

Hand Lever



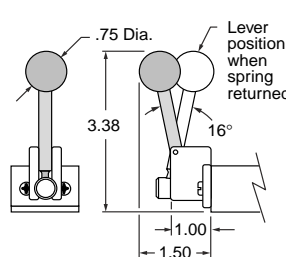

Hardened & plated steel shaft with unique connection to spool results in positive shifting. Standard 2 Way & 3 Way spring return are normally closed. For normally open specify by substituting -20 for -2 & -30 for -3.

Force to actuate:
Standard spring 4.0 lb.
Light spring (Option -L) . . 3.0 lb.
Detented 2.0 lb.

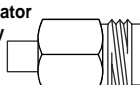

2 Way	3 Way	4 Way
Spring Return	18HLS-2	18HLS-3 18HLS-4
Detented	18HL-2	18HL-3 18HL-4
Replacement spool & seals	1800-932†	1800-933† 1800-934†
Light spring Option -L		

MOST THREADED-IN OPERATORS ARE INTERCHANGEABLE BETWEEN ENDS

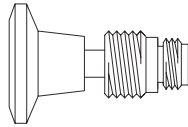
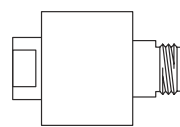
Palm Button Assembly  No. 1800-1 Large Button No. 1800-2 Small Button	Rod Actuator Assembly  No. 1800-3	Spring Housing Assembly  No. 1800-4 Light Spring only (for Option L). No. 1800-5 Standard Spring only No. 1800-46 Light Spring & Housing Ass'y (for Option -L). No. 1800-56 Standard Spring & Housing Assembly.	Pilot Bushing  No. 1800-10 10-32 Port No. 1800-18 1/8 NPT Port
Panel Mount Button Assembly For Detented (with Spool) No. 1800-7-2 (2W NC) 1800-7-20 (2W NO) 1800-7-3 (3W NC) 1800-7-30 (3W NO) Above NOT interchangeable End for End 1800-7-4 (4 Way) For Spring or Pilot Return (No Spool) 1800-8 (2 or 3 Way, NO or NC, and 4 Way)		Air Pilot Amplifier 1/8 NPT Standard  No. 18 AMP-1 1/8 NPT Port No. 10 AMP-1 10-32 Port Option -E	Fabco-Air has the expertise and willingness to design, modify and adapt these valves to your necessary and specific job requirements. Please advise us of your needs.

1/8 NPT Ported 53 STYLE Solenoid Controlled, Pilot Operated Air Valves 2, 3 & 4 Way - 2 Position – Operation to 150 psi Air

“The Finest in Simplicity”

The short stroke of the light weight Delrin® spool provides fast, positive and reliable response.

Features

- Aluminum bar stock body
- Black anodized
- Honed and burnished bore
- Lightweight Delrin® spool
- Buna N seals
- Operation to 150 psi
- Operating temperature:
0°F (-18°C) to +104°F (40°C) ambient.
0°F (-18°C) to +150°F (65°C) media.
- Coils & housing information see page 11.29
- Cv = 0.27
- 14.2 SCFM free flow to atmosphere @ 80 psi
- Prelubed with Magnalube®-G grease

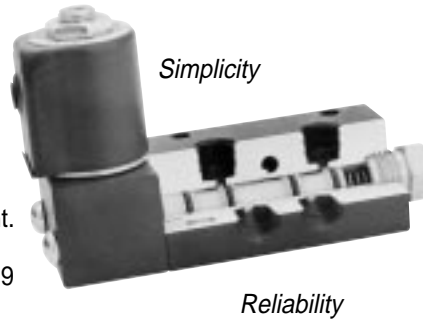

Options

- Manual Override
- Locking **-MO1**
- Non-Locking **-MO4**
- External Pilot **-X**
- Light Spring **-L**
- Viton Seals for media compatibility **-V**
- Explosion Proof Operators **-EP**
See page 11.30
- Dual Inlet - Single Exhaust 4 Way
See page 11.10
Note 1: Optional Flow Path



Operating Range

- Internal Pilot Supply (Standard)
 - Standard Spring 60 to 150 psi
 - Light Spring, Option **-L** .. 40 to 150 psi
 - Pilot Return (0 psi Pilot) .. 20 to 150 psi
- External Pilot Supply, Option **-X**
 - Inlet Pressure 0 to 150 psi
- External Pilot Supply, Option **-X**
 - Standard Spring 60 to 150 psi
 - Light Spring, Option **-L** .. 40 to 150 psi
 - Pilot Return (0 psi Pilot) .. 20 to 150 psi

SINGLE SOLENOID

To Order Specify: Model Number from chart
Options
Volts & Hertz (See page 11.29)

	2 WAY		3WAY		4 WAY
	Normally Closed	Normally Open	Normally Closed	Normally Open	
Conduit Housing	18CS-2	18CS-20	18CS-3	18CS-30	18CS-4
Grommet Housing	18GS-2	18GS-20	18GS-3	18GS-30	18GS-4
Male Mini-DIN Housing	18FS-2	18FS-20	18FS-3	18FS-30	18FS-4
Replacement Spool and Seals	1800-912	1800-9120	1800-913	1800-9130	1800-914

SINGLE SOLENOID - PILOT RETURN MODELS

A pilot return can be substituted for the standard spring return. It may be used in two manners.

1. For a pulse signal, then pilot return.
2. As a constant, adjustable force, spring.

Supply pilot port with a constant regulated pressure. This will act as a very constant spring against the solenoid controlled pilot signal. The pilot return should be a minimum of 20 psi below the solenoid controlled pressure.

To Specify, Substitute **P** for **S** in the Model Number.
(Example 18CP-3-120/60)

1/8 NPT Pilot Port standard.

10-32 Pilot Port optional, Specify Option **-E**.

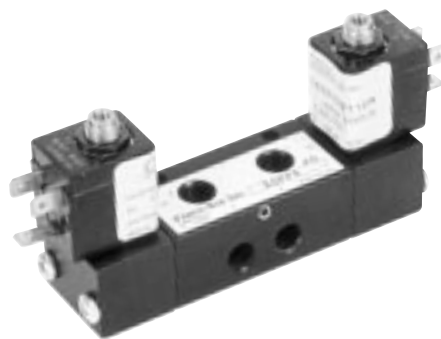

Operating Range

- Internal Pilot Supply (Standard)
 - Inlet 20 to 150 psi
- External Pilot Supply, Option **-X**
 - Inlet Pressure 0 to 150 psi
 - Pilot Supply 20 to 150 psi

DOUBLE SOLENOID

To Order Specify: Model Number from chart
Options
Volts & Hertz (See page 11.29)

	2 WAY	3WAY	4 WAY
	Conduit Housing	18CC-2	18CC-3
Grommet Housing	18GG-2	18GG-3	18GG-4
Male Mini-DIN Housing	18FF-2	18FF-3	18FF-4
Replacement Spool and Seals	1800-922	1800-923	1800-924

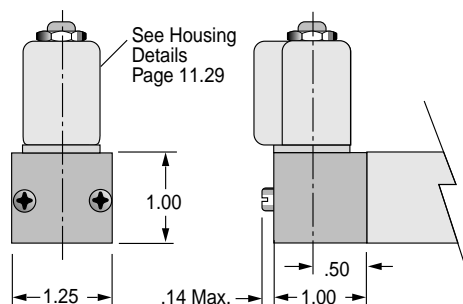

Standard 53 STYLE Solenoid Operator

The solenoid operator is a 3-way NC valve which, upon receiving an electrical signal, directs a pilot pressure to shift the main valve spool. As standard, the operator is internally supplied with air pressure from the main valve inlet. Also see "External Pilot Supply" below.

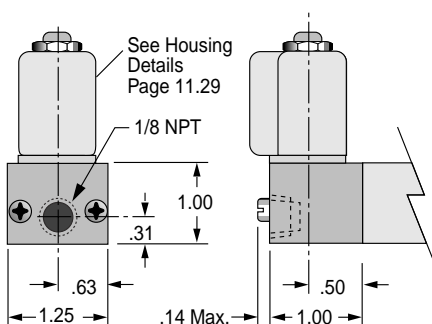

53 STYLE Solenoid Operator with External Pilot Supply

Option -X

In the following listed applications, as well as many others, a proper air supply may not be available from the main valve inlet. For these applications, an external pilot supply port is available (Option -X). A proper air supply to this port then supplies the solenoid with air pressure for piloting the main valve spool.

- Dual Inlet - Single Exhaust 4 Way.
- Insufficient pressure at main valve inlet.
- Media, at main valve inlet, other than air.
- Extremely fast cycling.

Option -X is NOT combinable with either Option -MO1 or -MO4

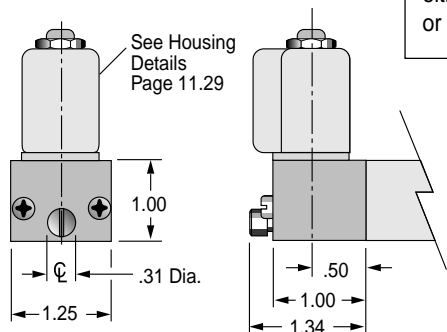

53 STYLE Solenoid Operator with Manual Override

This manual override is a 3-way NC valve that when pushed, directs pilot pressure to shift the main spool. Pressure must be present at main valve inlet for this override to function.

TYPE	SUFFIX
LOCKING Push to override; Turn to lock in; Turn back to release.	-MO1
NON-LOCKING Push to override.	-MO4

2 WAY

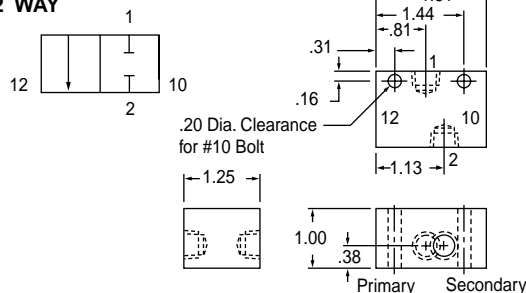

Spring Return Valves	End	Operator
Normally Closed	10	Spring
	12	Solenoid
Normally Open	10	Solenoid
	12	Spring

3 Way

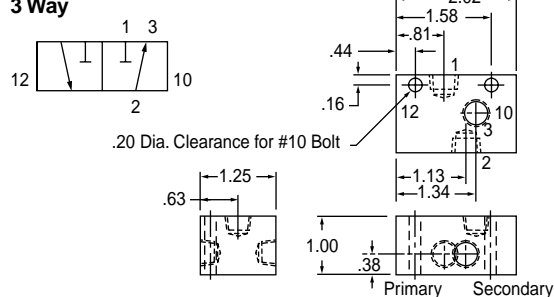

Spring Return Valves	End	Operator
Normally Closed	10	Spring
	12	Solenoid
Normally Open	10	Solenoid
	12	Spring

4 Way - Standard: Single Inlet - Port #1 - Dual Exhaust

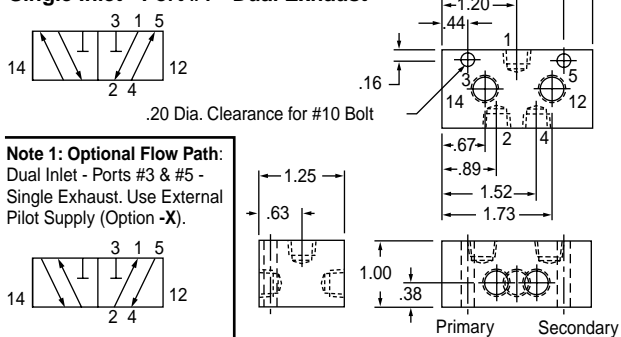

Note 1: Optional Flow Path:
Dual Inlet - Ports #3 & #5 - Single Exhaust. Use External Pilot Supply (Option -X).

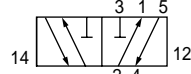

Spring Return: Standard and Optional Light

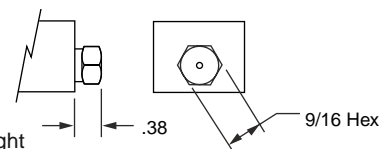

Pilot Return: -P

See Page 11.7

1/8 NPT Port Standard - 10-32 Port Specify Option -E

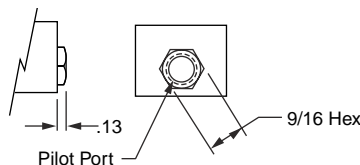

**1/8 NPT Ported 58 STYLE Solenoid Controlled, Pilot Operated Air Valves
2, 3 & 4 Way - 2 Position – Operation to 150 psi Air**

“The Finest in Simplicity”

The short stroke of the light weight Delrin® spool provides fast, positive and reliable response.



Features

- Aluminum bar stock body
- Black anodized
- Honed and burnished bore
- Lightweight Delrin® spool
- Simplicity
- Reliability
- Corrosion resistant construction
- Buna N seals
- Operating temperature:
 - 5°F (–15°C) to +122°F (50°C) ambient.
 - 5°F (–15°C) to +122°F (50°C) media.
- Solenoid operator information
see page 11.31
- Cv = 0.27
- 14.2 SCFM Free flow to atmosphere @ 80 psi
- Prelubed with Magnalube® -G grease

Options

- External Pilot **-X**
- † External Pilot and Viton Seals **-XV**
- Light Spring **-L**

† Viton Seals are available in the main valve only, for media compatibility, and therefore only in conjunction with External Pilot –5°F (–15°C) to +122°F (50°C).

Operating Ranges, psi

	#1 Solenoid 0.9 Watts	#4 Solenoid 3.5 Watts
Internal Pilot Supply (Standard) Inlet Pressure		
Non Spring Return	20 to 130	20 to 145
Spring Return	60 to 130	60 to 145
Light Spring Option -L	40 to 130	40 to 145
External Pilot Supply, Option -X Inlet Pressure . . .		
	0 to 150	0 to 150
External Pilot Supply, Option -X Pilot Supply		
Non Spring Return	20 to 130	20 to 145
Spring Return	60 to 130	60 to 145
Light Spring Option -L	40 to 130	40 to 145

58 STYLE Solenoid Valve, Model Number Code

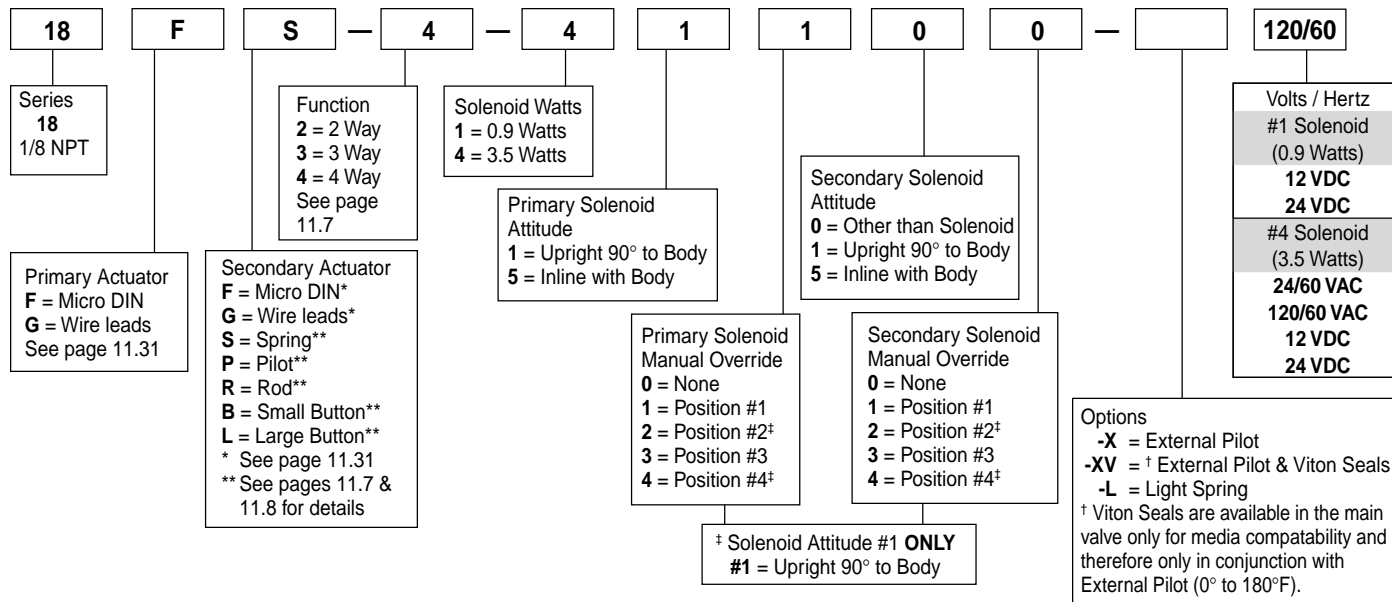

Example: 18FS-4-41100-120/60

1/8 NPT – Primary Actuator Solenoid with Micro DIN coil; Secondary Actuator, Spring Return – 4 Way Function 3.5 Watt Solenoid; Primary Solenoid Upright position with Manual Override in Position #1; Secondary Actuator is not a Solenoid; no Manual Override on Secondary Actuator – No Options – 120 Volt/60 Hertz.

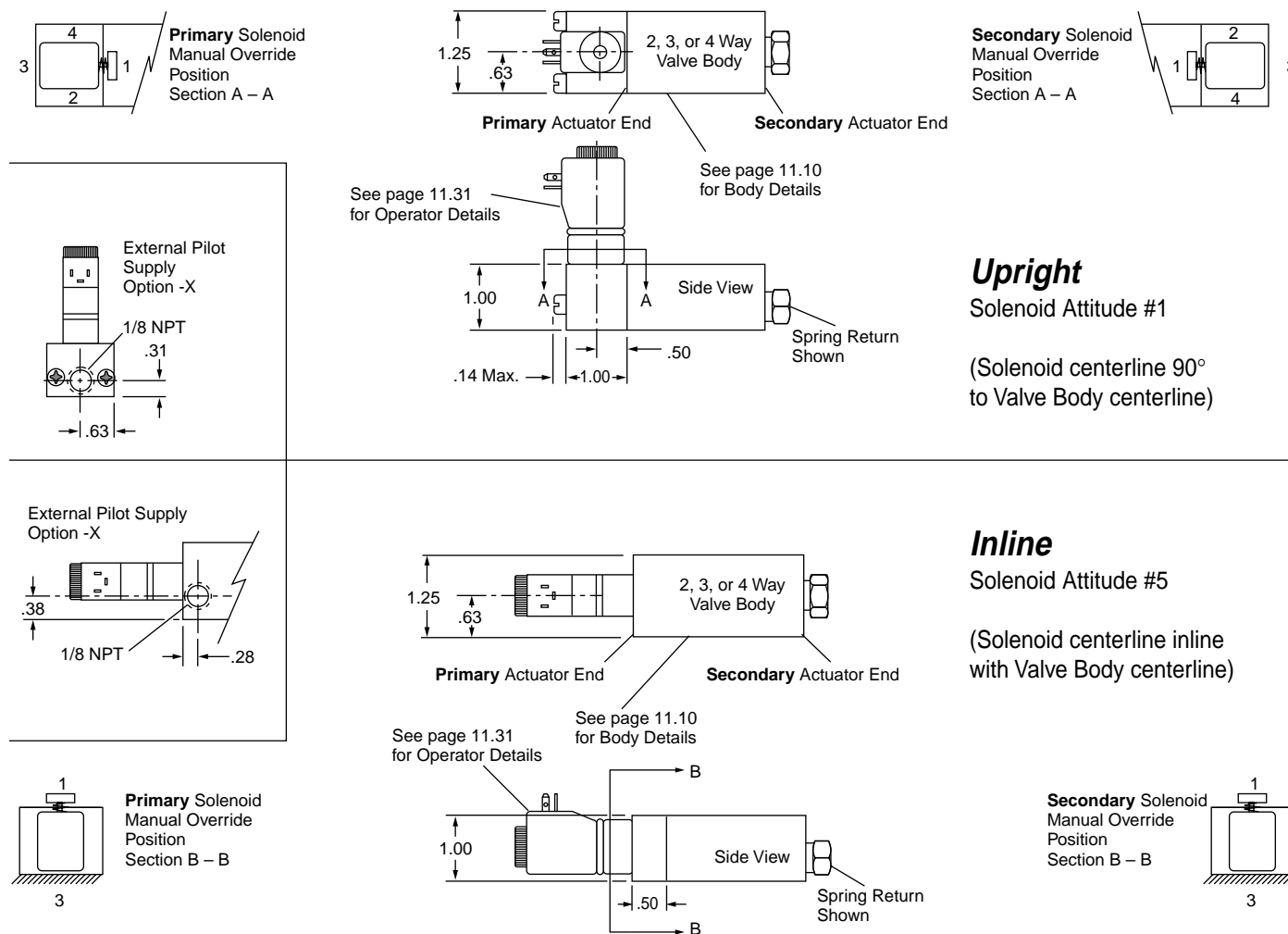

11

Directional Control Valves

1/4 & 3/8 NPT
2, 3 & 4 Way

14, M14 & 34 Series

1/4 & 3/8 NPT PORTED, MANUAL, MECHANICAL AND PILOT OPERATED AIR VALVES – “The Finest in Simplicity”
2, 3 and 4 Way - 2 Position – Operation to 150 psi Air

Suitable for Vacuum directional flow applications, but NOT for holding vacuum.

The short stroke of the lightweight Delrin® spool provides fast, positive, and reliable response.

Note 1: Specify Normally Open by substituting -30 for -3.

Air Pilot



Brass bushing with 1/8 NPT port. Standard 3 Way spring return is normally closed. For normally open the actuators may be exchanged end for end or by specifying -30 for -3. Minimum pilot pressure:
Standard spring 50 psi
Light spring (Option-L) 40 psi
Double pilot 20 psi

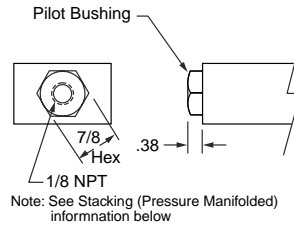

	3 Way	4 Way
Single Pilot - Spring Return		
1/4 NPT	14SP-3	14SP-4
1/4 Stacking	N/A	M14SP-4
3/8 NPT	34SP-3	34SP-4
Double Pilot		
1/4 NPT	14DP-3	14DP-4
1/4 Stacking	N/A	M14DP-4
3/8 NPT	34DP-3	34DP-4
Replacement spool & seals	1400-903	1400-904

Rod Actuator



Plated steel rod in brass bushing. Standard 3 Way spring return is normally closed. For normally open the actuators may be exchanged end for end or specify by substituting -30 for -3. Force to actuate:
Standard spring 10.5 lb.
Light spring (Option-L) 9.0 lb.
Double rod 1.2 lb.

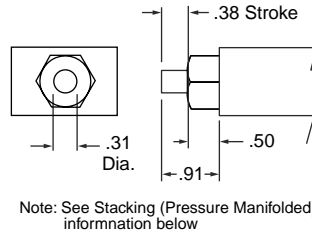

	3 Way	4 Way
Single Rod - Spring Return		
1/4 NPT	14SR-3	14SR-4
1/4 Stacking	N/A	M14R-4
3/8 NPT	34SR-3	34SR-4
Single Rod - Pilot Return		
1/4 NPT	14SRP-3	14SRP-4
1/4 Stacking	N/A	M14SRP-4
3/8 NPT	34SRP-3	34SRP-4
Double Rod		
1/4 NPT	14DR-3	14DR-4
1/4 Stacking	N/A	M14DR-4
3/8 NPT	34DR-3	34DR-4
Replacement spool & seals	1400-903	1400-904

Roller Cam



Case hardened steel roller and shaft in hard anodized aluminum housing. Standard 3 Way spring return is normally closed. For normally open specify by substituting -30 for -3. Force to actuate:
Standard spring 10.5 lb.
Light spring (Option-L) 9.0 lb.
Cam-Pilot return 1.2 lb.

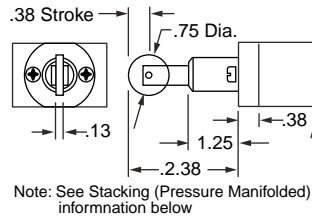

	3 Way	4 Way
Single Cam - Spring Return		
1/4 NPT	14CR-3	14CR-4
1/4 Stacking	N/A	M14CR-4
3/8 NPT	34CR-3	34CR-4
Single Cam - Pilot Return		
1/4 NPT	14CRP-3	14CRP-4
1/4 Stacking	N/A	M14CRP-4
3/8 NPT	34CRP-3	34CRP-4
Replacement spool & seals for above	1400-913	1400-914
Double cam		
1/4 NPT	14CCR-3	14CCR-4
1/4 Stacking	N/A	M14CCR-4
3/8 NPT	34CCR-3	34CCR-4
Replacement spool & seals	1400-923	1400-924

Stacking - Pressure Manifold



Selected models of the 14 Series 1/4" air valves can be stacked and pressure manifolded for space and money savings. The valve bodies are bolted together with 4 through tie bolts and the pressure is manifolded with O-Ring seals between the valves. Inlet pressure can be connected to either or both ends of the stack. Due to the fact that the pressure port, on all valve bodies, is tapped on both sides, the pressure manifold can be plugged at any point within the stack. This allows you to supply the stack with two different pressures, one from each end.

See Model Numbers in the Air-Pilot Rod Actuator, Roller Cam and Small Palm Button sections of Pgs 11.13 and 11.14 and Solenoid Valves on Pgs 11.19 and 11.20.

To Order: Specify the Quantity of each model desired, the Order in which they are to be assembled, and Brackets, if desired.

11

Spring Cap Dimensions

STANDARD SPRING

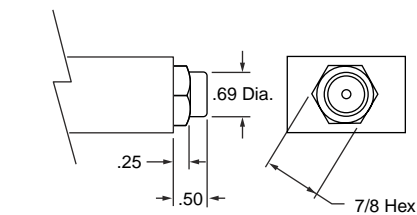

LIGHT SPRING

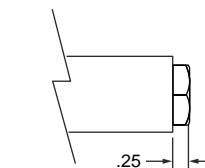

OPTION -L

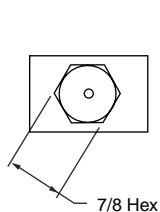

Valve Body Dimensions

2 Way / 3 Way

This 3 Way Valve may be used for any 2 Way, 3 Way, Selector or Diverter service.

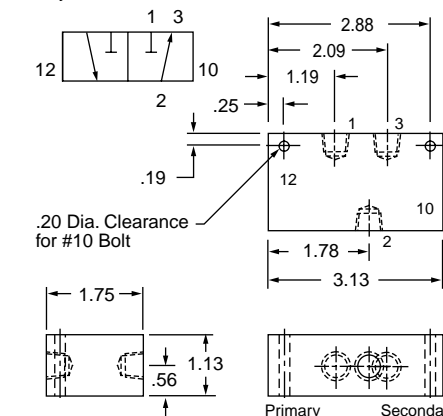

4 Way - 5 Port ‡

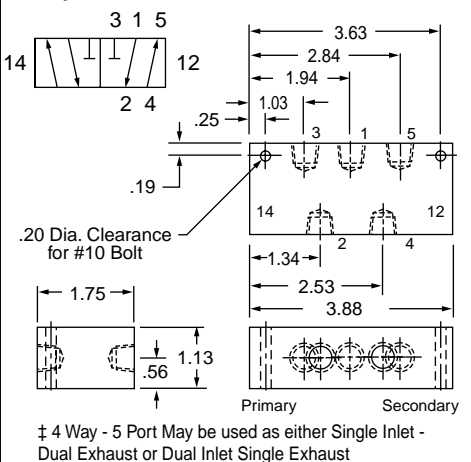

‡ 4 Way - 5 Port May be used as either Single Inlet - Dual Exhaust or Dual Inlet Single Exhaust

Directional Control Valves

1/4 & 3/8 NPT
2, 3 & 4 Way

14, M14 & 34 Series

- Aluminum bar body
- Anodized black
- Honed & burnished bore
- Pressure balanced spool
- Delrin spool
- Buna-N seals
- Operation to 150 psi
- 4 Way - 5 port may be used as either single inlet - dual exhaust or dual inlet - single exhaust.

FEATURES

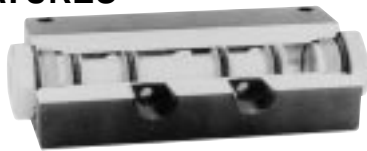

- Prelubed with Magnalube®-G Grease
- Interchangeability of Parts
- Cv = 1.0
- 56.2 SCFM Free Flow to Atmosphere at 80 psi Supply
- Operating Temperature 0° to +180°F; Solenoid controlled models +150°F max. See pages 11.17, 11.19 & 11.21.

OPTIONS

- Light spring – Specify Option -L
- Viton seals – Specify Option -V
- Spools for bleeder pilot – Consult factory.

Note 1: Specify Normally Open by substituting -30 for -3.

Small Palm Button



Un-anodized aluminum button with plated steel rod in brass bushing. Standard 3 Way spring return is normally closed. For normally open the actuators may be exchanged end for end or specify by substituting -30 for -3.

Force to actuate:
Standard spring 10.5 lb.
Light spring (Option -L) 9.0 lb.
Double Button 1.2 lb.

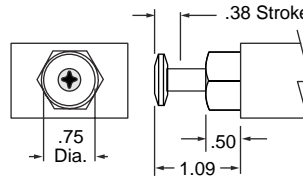

	3 Way	4 Way
Single Button - Spring Return	14PS-3	14PS-4
1/4 NPT	N/A	M14PS-4
1/4 Stacking	34PS-3	34PS-4
3/8 NPT	14PSP-3	14PSP-4
Single Button - Pilot Return	N/A	M14PSP-4
1/4 NPT	34PSP-3	34PSP-4
1/4 Stacking	14PPS-3	14PPS-4
3/8 NPT	N/A	M14PPS-4
Double Button	34PPS-3	34PPS-4
1/4 NPT	1400-903	1400-904
1/4 Stacking		
3/8 NPT		
Replacement spool & seals		

Large Palm Button



Red anodized aluminum button with plated steel rod in brass bushing. Standard 3 Way spring return is normally closed. For normally open the actuators may be exchanged end for end or specify by substituting -30 for -3.

Force to actuate:
Standard spring 10.5 lb.
Light spring (Option -L) 9.0 lb.
Double Button 1.2 lb.

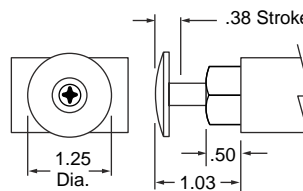

	3 Way	4 Way
Single Button - Spring Return	14PL-3	14PL-4
1/4 NPT	34PL-3	34PL-4
3/8 NPT	14PLP-3	14PLP-4
Single Button - Pilot Return	34PLP-3	34PLP-4
1/4 NPT	14PPL-3	14PPL-4
3/8 NPT	34PPL-3	34PPL-4
Double Button	1400-903	1400-904
1/4 NPT		
3/8 NPT		
Replacement spool & seals		

Panel Mount Button



Phenolic button with plated steel rod in brass bushing; **black** button standard, **red** button Option -R. Standard 3 Way assemblies are normally closed with knob in the "out" position. For normally open specify by substituting -30 for -3.

Force to actuate:
Standard spring 10.5 lb.
Light spring (Option -L) ... 9.0 lb.
Detented 3.0 lb.

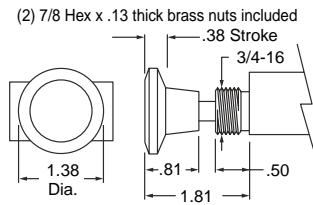

	3 Way	4 Way
Spring Return	14PMS-3	14PMS-4
1/4 NPT	34PMS-3	34PMS-4
3/8 NPT	14PMP-3	14PMP-4
Pilot Return	34PMP-3	34PMP-4
1/4 NPT	14PMD-3	14PMD-4
3/8 NPT	34PMD-3	34PMD-4
Detented (Push Pull)	1400-903	1400-904
1/4 NPT	14PMD-3	14PMD-4
3/8 NPT	34PMD-3	34PMD-4
Replacement spool & seals	1400-943†	1400-944†
	1400-933†	1400-934†

Hand Lever



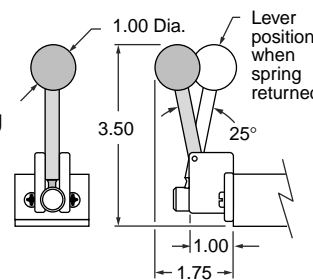

Hardened & plated steel shaft with unique connection to spool results in positive shifting. Standard 3 Way spring return is normally closed. For normally open specify by substituting -30 for -3.

Force to actuate:
Standard spring . . . 10.0 lb.
Light spring 6.0 lb.
(Option -L)
Detented 3.0 lb.

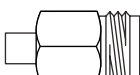

	3 Way	4 Way
Spring Return	14HLS-3	14HLS-4
1/4 NPT	34HLS-3	34HLS-4
3/8 NPT	14HL-3	14HL-4
Detented	34HL-3	34HL-4
1/4 NPT		
3/8 NPT		
Replacement spool & seals	1400-933†	1400-934†

MOST THREADED-IN OPERATORS ARE INTERCHANGEABLE BETWEEN ENDS

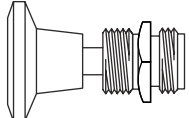
Palm Button Assembly	Rod Actuator Assembly	Spring Housing Assembly	Pilot Bushing
 <p>No. 1400-1 Large Button No. 1400-2 Small Button</p>	 <p>No. 1400-3</p>	 <p>No. 1400-4 Light Spring only (for Option -L) No. 1400-5 Standard Spring only No. 1400-46 Light Spring & Housing Assembly (for Option -L). No. 1400-56 Standard Spring & Housing Assembly .</p>	 <p>No. 1400-18 1/8 NPT Port</p>
<p>Panel Mount Button Assembly</p>  <p>Black button standard Red button Option -R</p>	<p>For Detented (with Spool) No. 1400-7-3 (3 Way Normally Closed) 1400-7-30 (3 Way Normally Open) Above NOT interchangeable End for End 1400-7-4 (4 Way) For Spring or Pilot Return (No Spool) 1400-8 (3 Way N.O. or N.C., and 4 Way)</p>	<p>Fabco-Air has the expertise and willingness to design, modify and adapt these valves to your necessary and specific job requirements. Please advise us of your needs.</p>	

1/4 NPT & 3/8 NPT Ported, Manual & Pilot Operated, & Solenoid Controlled Air Valves

New 5 Ported, 3-Position 4-Way Operation

New Spools for 14 & 34 Series Air Valves

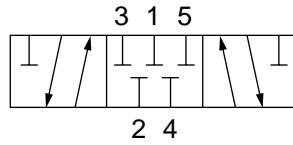

4-Way - 5 Ported - 3 Position - Type B
"Blocked"

Center position - All ports blocked and isolated. Use on conventional block and hold circuits.

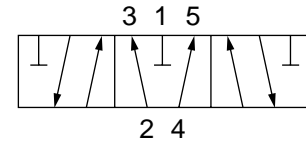

4-Way - 5 Ported - 3 Position - Type F
"Float"

Center position - Inlet blocked and cylinders open to exhaust. Used to vent both ends of cylinder to allow cylinder to float with a manual or machine movement. Flow controls or exhaust speed controls should not be used.

1/4 NPT & 3/8 NPT Ported, Pilot Operated Air Valves

5 Ported, 3-Position 4-Way Operation



Model 14-DPF Shown

Features

- Aluminum bar body
- Anodized black
- Honed and burnished bore
- Delrin spool, pressure balanced
- Buna N seals
- May be used as either
single inlet-dual exhaust or
dual inlet-single exhaust
- Pre-lubed with Magnalube-G® Grease

Operating Range

- Operating pressure 0 to 150 psi
- Minimum pilot pressure 50 psi
- Temperature 0° to 180°F
- Cv = 1.0 (56.2 SCFM free flow to atmosphere @ 80 psi supply)

Options

Viton Seals, Specify Option -V

Model Number Guide: 3-Position, Pilot Operated

Spool Type	Spring Centered Spool		Replacement Spool and Seals
	1/4 NPT Ports	3/8 NPT Ports	
B Spool	14 DPB	34DPB	1400-904B
F Spool	14DPF	34DPF	1400-904F

Valve Dimensions

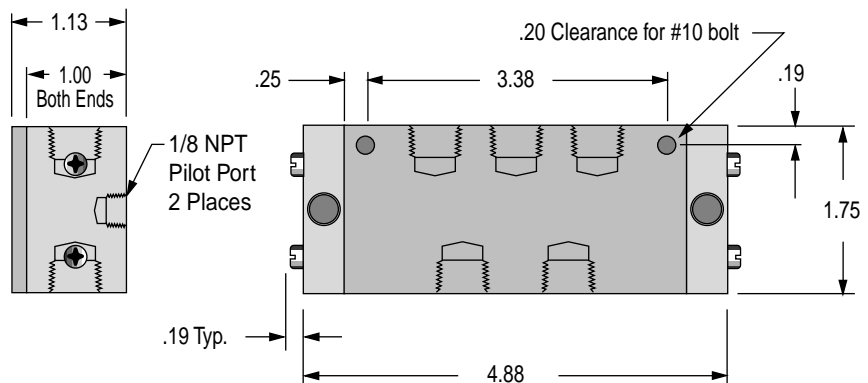

1/4 NPT & 3/8 NPT Ported, Hand Lever Operated Air Valves

5 Ported, 3-Position 4-Way Operation



Model 14-HLF Shown

Features

Hardened and plated steel shaft with unique connections results in positive shifting

- Aluminum bar body
- Anodized black
- Honed and burnished bore
- Delrin spool, pressure balanced
- Buna N seals
- May be used as either
single inlet-dual exhaust or
dual inlet-single exhaust
- Pre-lubed with Magnalube-G® Grease

Operating Range

- Operating pressure 0 to 150 psi
- Temperature 0° to 180°F
- Cv = 1.0 (56.2 SCFM free flow to atmosphere @ 80 psi supply)

Options

Viton Seals, Specify Option -V

Model Number Guide: 3-Position, Hand Lever Operated

Spool Type	Spring Centered Spool		Replacement Spool & Seals	Detented Spool		Replacement Spool & Seals
	1/4 NPT Ports	3/8 NPT Ports		1/4 NPT Ports	3/8 NPT Ports	
B Spool	14HLSB	34HLSB	1400-934SB	14HLB	34HLB	1400-934B
F Spool	14HLSF	34HLSF	1400-934SF	14HLF	34HLF	1400-934F

Dimensions – Spring Centered Spool

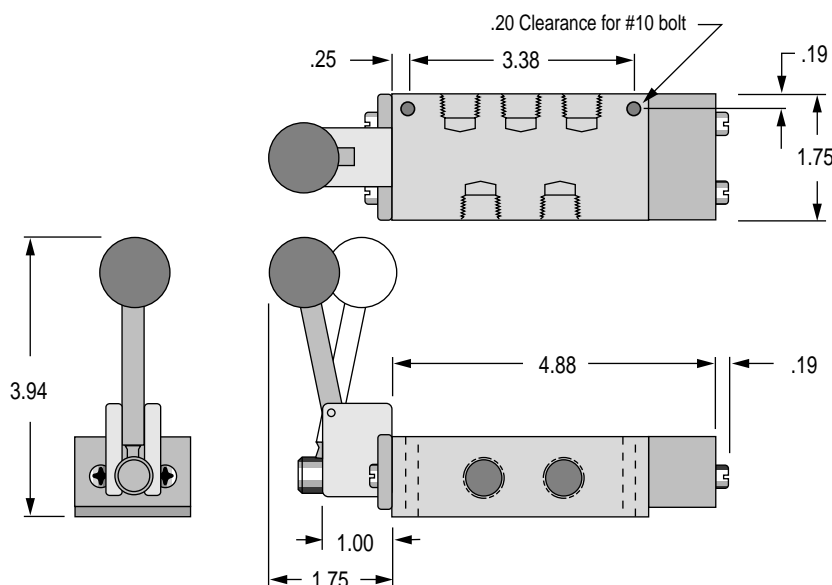

Dimensions – Detented Spool

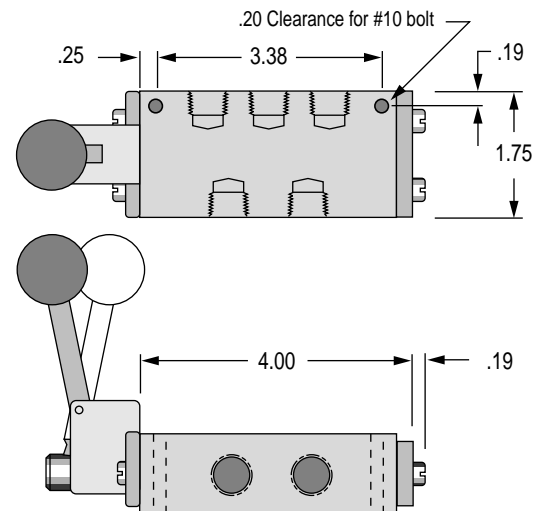

1/4 NPT & 3/8 NPT Ported, 53 Style Solenoid Controlled, Pilot Operated Air Valves

5 Ported, 3-Position 4-Way Operation

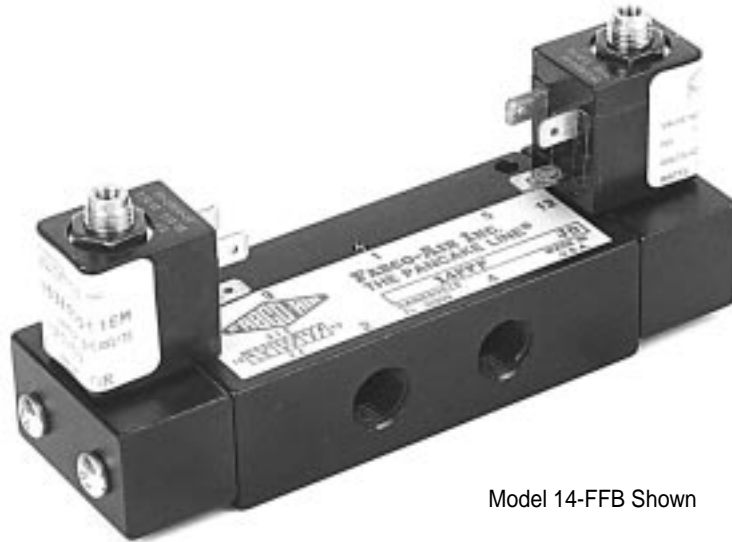

Model 14-FFB Shown

Features

- Aluminum bar body
- Anodized black
- Honed and burnished bore
- Delrin spool
- Buna N seals
- Cv = 1.0 (56.2 SCFM free flow to atmosphere @ 80 psi supply)
- Operation to 150 psi
- Operating Temperature:
 - 0°F (-18°C) to +104°F (40°C) ambient.
 - 0°F (-18°C) to +150°F (65°C) media.
- Pre-lubed with Magnalube-G® Grease
- Coils & Housing information see page 11.29.

Operating Range

- Internal pilot supply - standard
 Inlet 50 to 150 psi
- External pilot supply Option -X
 Inlet 0 to 150 psi
 Pilot Supply 50 to 150 psi

Ordering

Choose valve model number from table below and add option suffixes as required and specify voltage/hertz.

Model Number Guide: 4-Way, 3-Position, Spring Centered Double Solenoid Valves

Spool Type	Conduit Housing "C"		Grommet Housing "G"		Male Mini-DIN Housing "F"		Replacement Spool & Seals
	1/4 NPT Ports	3/8 NPT Ports	1/4 NPT Ports	3/8 NPT Ports	1/4 NPT Ports	3/8 NPT Ports	
B Spool	14-CCB	34-CCB	14-GGB	34-GGB	14-FFB	34-FFB	1400-904B
F Spool	14-CCF	34-CCF	14-GGF	34-GGF	14-FFF	34-FFF	1400-904F

53 Style Solenoid Operators

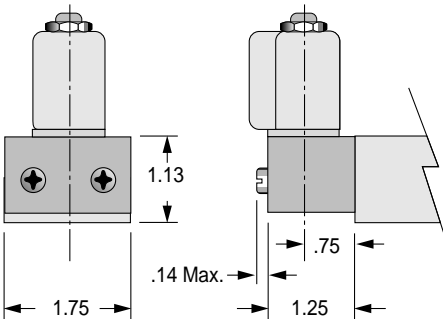

Standard 53 Style Operator

The solenoid operator is a 3-way NC valve which, upon receiving an electrical signal, directs pressure to shift the main valve spool. As standard, the operator is internally supplied with air pressure from the main valve inlet.

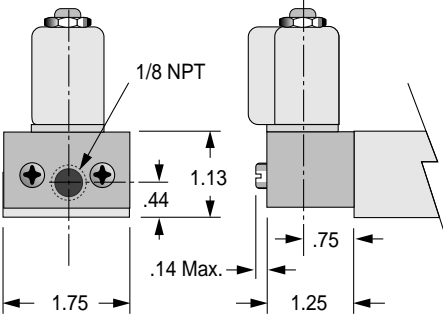

53 Style Operator with External Pilot Option -X

In the following listed applications, as well as many others, a proper air supply may not be available from the main valve inlet. For these applications, an external pilot supply port is available (Option -X). A proper air supply to this port then supplies the solenoid with air pressure for piloting the main valve spool.

- Dual inlet, single exhaust
- Insufficient Pressure at main valve inlet
- Media at main valve inlet is other than air
- Extreme fast cycling

Valve Dimensions

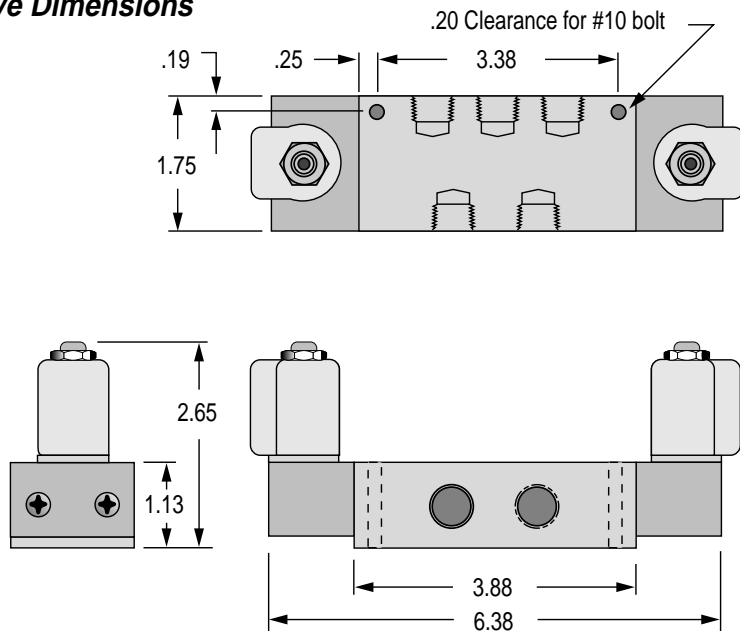

Conduit Housing "C"

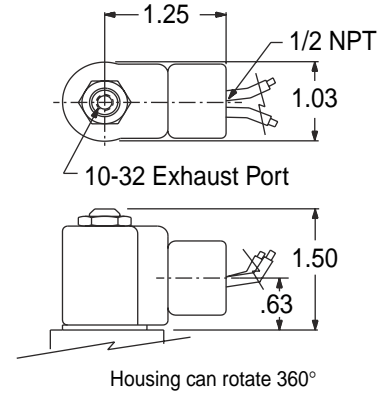

Grommet Housing "G"

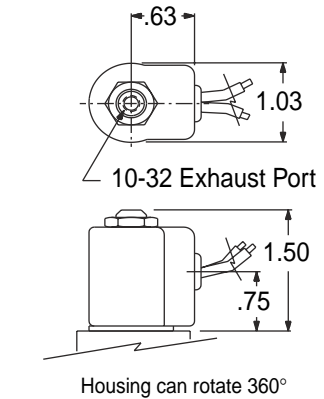

Male Mini-DIN Housing "F"

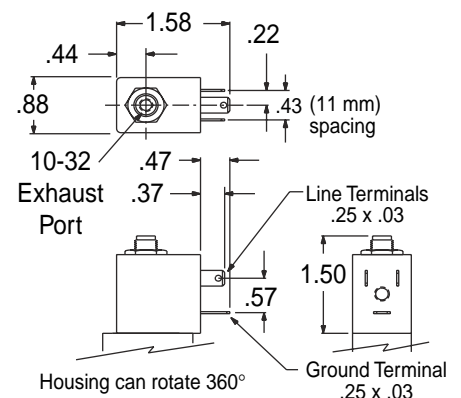

1/4 & 3/8 NPT Ported 53 STYLE Solenoid Controlled, Pilot Operated Air Valves 2, 3 & 4 Way - 2 Position – Operation to 150 psi Air

“The Finest in Simplicity”

Features

The short stroke of the light weight Delrin® spool provides fast, positive and reliable response.

- Aluminum bar stock body
- Black Anodized
- Honed and burnished bore
- Lightweight Delrin® spool
- Buna N seals
- Operation to 150 psi
- Operating temperature:
0°F (-18°C) to +104°F (40°C) ambient.
0°F (-18°C) to +150°F (65°C) media.
- Coils & housing Information see page 11.29
- Cv = 1.0
- 56.2 SCFM free flow to atmosphere @ 80 psi
- Prelubed with Magnalube® -G grease

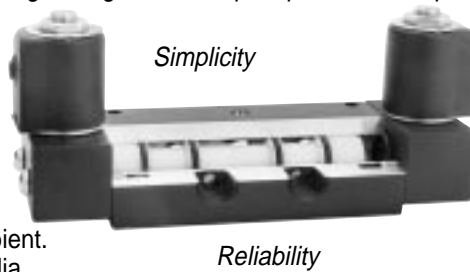

Options

- Manual override
- Locking -MO1
- Non-Locking -MO4
- External pilot -X
- Light spring -L
- Viton seals for media compatibility . . . -V
- Explosion proof operators -EP
See page 11.30
- Dual Inlet - Single Exhaust 4 Way
See page 11.20
- Note 1: Optional Flow Path.



Operating Range

- Internal Pilot Supply (Standard)
- Standard Spring 50 to 150 psi
 - Light Spring, Option -L . . . 40 to 150 psi
 - Pilot Return (0 psi Pilot) . . 30 to 150 psi
- External Pilot Supply, Option -X
- Inlet Pressure 0 to 150 psi
- External Pilot Supply, Option -X
- Standard Spring 50 to 150 psi
 - Light Spring, Option -L . . . 40 to 150 psi
 - Pilot Return (0 psi Pilot) . . 30 to 150 psi

11



Operating Range

- Internal Pilot Supply (Standard)
- Inlet 30 to 150 psi
- External Pilot Supply, Option -X
- Inlet Pressure 0 to 150 psi
 - Pilot Supply 30 to 150 psi

11.19

SINGLE SOLENOID

To Order Specify: Model Number from chart

Options
Volts & Hertz (See page 11.29)

‡Plug 3-Way Valve
for 2-Way Service.

	1/4 NPT PORTS				3/8 NPT PORTS		
	‡2 / 3 WAY		4 WAY	4 WAY Stacking See pg 11.20	‡2 / 3WAY		4 WAY
	Normally Closed	Normally Open			Normally Closed	Normally Open	
Conduit Housing	14CS-3	14CS-30	14CS-4	M14CS-4	34CS-3	34CS-30	34CS-4
Grommet Housing	14GS-3	14GS-30	14GS-4	M14GS-4	34GS-3	34GS-30	34GS-4
Male Mini-DIN Housing	14FS-3	14FS-30	14FS-4	M14FS-4	34FS-3	34FS-30	34FS-4
Replacement Spool & Seals	1400-913	1400-9130	1400-914	1400-904	1400-913	1400-9130	1400-914

SINGLE SOLENOID - PILOT RETURN MODELS

A pilot return can be substituted for the standard spring return. It may be used in two manners.

1. For a pulse signal, then pilot return.
2. As a constant, adjustable force, spring.

Supply pilot port with a constant regulated pressure. This will act as a very constant spring against the solenoid controlled pilot signal. The pilot return should be a minimum of 30 psi below the solenoid controlled pressure.

To Specify, Substitute P for S in the Model Number. (Ex: 14CP-3-120/60)

DOUBLE SOLENOID

To Order Specify: Model Number from chart

Options
Volts & Hertz (See page 11.29)

‡Plug 3-Way Valve
for 2-Way Service.

	1/4 NPT PORTS			3/8 NPT PORTS	
	‡2 / 3 WAY	4 WAY	4 WAY Stacking See pg 11.20	‡2 / 3 WAY	4 WAY
	Conduit Housing	14CC-3	14CC-4	M14CC-4	34CC-3
Grommet Housing	14GG-3	14GG-4	M14GG-4	34GG-3	34GG-4
Male Mini-DIN Housing	14FF-3	14FF-4	M14FF-4	34FF-3	34FF-4
Replacement Spool & Seals	1400-923	1400-924	1400-904	1400-923	1400-924

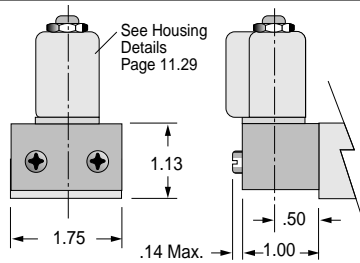

Standard 53 STYLE Solenoid Operator

The solenoid operator is a 3-way NC valve which, upon receiving an electrical signal, directs a pilot pressure to shift the main valve spool. As standard, the operator is internally supplied with air pressure from the main valve inlet. Also see "External Pilot Supply" below.

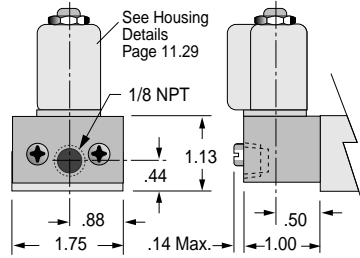

53 STYLE Solenoid Operator with External Pilot Supply

Option -X

In the following listed applications, as well as many others, a proper air supply may not be available from the main valve inlet. For these applications, an external pilot supply port is available (Option -X). A proper air supply to this port then supplies the solenoid with air pressure for piloting the main valve spool.

- Dual Inlet - Single Exhaust 4 Way.
- Insufficient pressure at main valve inlet.
- Media, at main valve inlet, other than air.
- Extremely fast cycling.

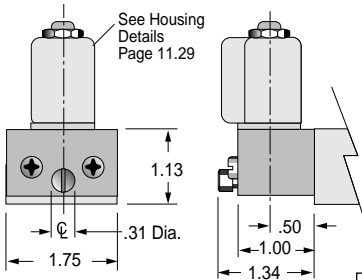

53 STYLE Solenoid Operator with Manual Override

This manual override is a 3-way NC valve that when pushed, directs pilot pressure to shift the main spool. Pressure must be present at main valve inlet for this override to function.

TYPE	SUFFIX
LOCKING Push to override; Turn to lock in; Turn back to release.	-MO1
NON-LOCKING Push to override.	-MO4

Option -X is NOT combinable with either Option -MO1 or -MO4

3 Way

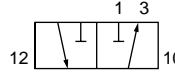

2 Way Function

This 3 Way Valve may be used for any 2 Way, 3 Way, Selector or Diverter service.

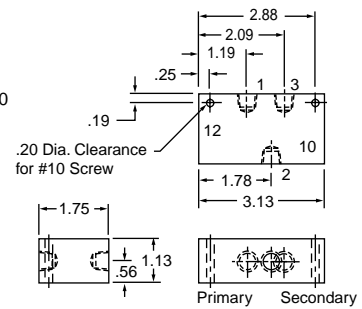

Spring Return Valves	End	Operator
Normally Closed	10	Spring
	12	Solenoid
Normally Open	10	Solenoid
	12	Spring

4 Way - 5 Port

Standard: Single Inlet - Port #1 - Dual Exhaust.

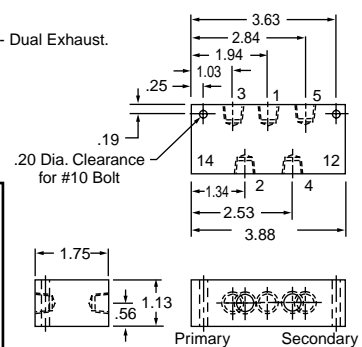
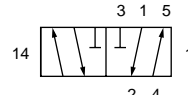

Note 1: Optional Flow Path: Dual Inlet - Ports #3 & #5 - Single Exhaust. Use External Pilot Supply (Option -X).

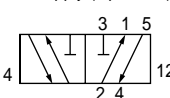

Standard Spring Return

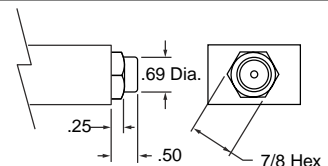

Light Spring Return Option -L

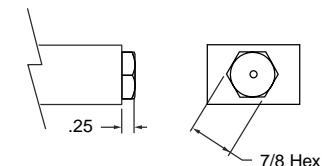

Pilot Return Option -P 1/8 NPT Port See Page 11.13

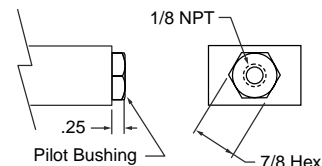

STACKING - PRESSURE MANIFOLDED

Versions of these 1400 Series 1/4 NPT solenoid valves with different adaptor blocks can be stacked and pressure manifolded for space and money savings. The valve bodies are bolted together with 4 through tie bolts and the pressure is manifolded with O-Ring seals between valves. Inlet pressure can be connected to either or both ends of the stack. Due to the fact that the pressure port, on all valve bodies, is tapped on both sides, the pressure manifold can be plugged at any point within the stack. This allows you to supply the stack with two different pressures, one from each end.

Versions of the Air Pilot, Rod Actuator, Roller Cam and Small Palm Button valves may be mounted in the same stack along with these solenoid valves.

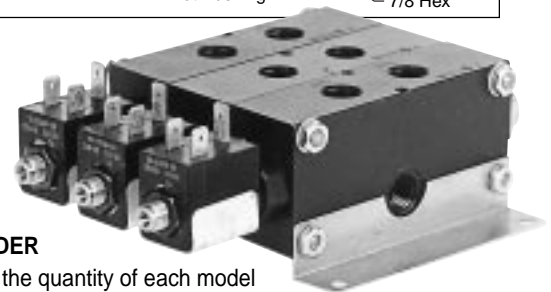

TO ORDER

Specify the quantity of each model desired, the order in which they are to be assembled, and Brackets, if desired.

1/4 & 3/8 NPT Ported 58 STYLE Solenoid Controlled, Pilot Operated Air Valves 2, 3 & 4 Way - 2 Position

“The Finest in Simplicity”

The short stroke of the light weight Delrin® spool provides fast, positive and reliable response.



Features

- Aluminum bar stock body
- Black anodized
- Honed and burnished bore
- Lightweight Delrin® spool
- Simplicity
- Reliability
- Buna N Seals
- Corrosion resistant construction
- Operating temperature:
 - 5°F (–15°C) to +122°F (50°C) ambient.
 - 5°F (–15°C) to +122°F (50°C) media.
- Solenoid operator information
see page 11.31
- Cv = 1.0
- 56.2 SCFM Free flow to atmosphere @ 80 psi
- Plug 3 Way Valve for 2 Way service
- Prelubed with Magnalube® -G grease

Operating Ranges, psi

	#1 Solenoid 0.9 Watts	#4 Solenoid 3.5 Watts
Internal pilot supply (standard) inlet pressure		
Non Spring Return	30 to 130	30 to 145
Spring Return	50 to 130	50 to 145
Light Spring Option -L	40 to 130	40 to 145
External pilot supply, Option -X inlet pressure . . . 0 to 150		
External pilot supply, Option -X pilot supply		
Non Spring Return	30 to 130	30 to 145
Spring Return	50 to 130	50 to 145
Light Spring Option -L	40 to 130	40 to 145

Options

- External Pilot -X
- † External Pilot and Viton Seals -XV
- Light Spring -L

† Viton Seals are available in the main valve only, for media compatibility, and therefore only in conjunction with External Pilot: –5°F (–15°C) to +122°F (50°C).

58 STYLE Solenoid Valve, Model Number Code

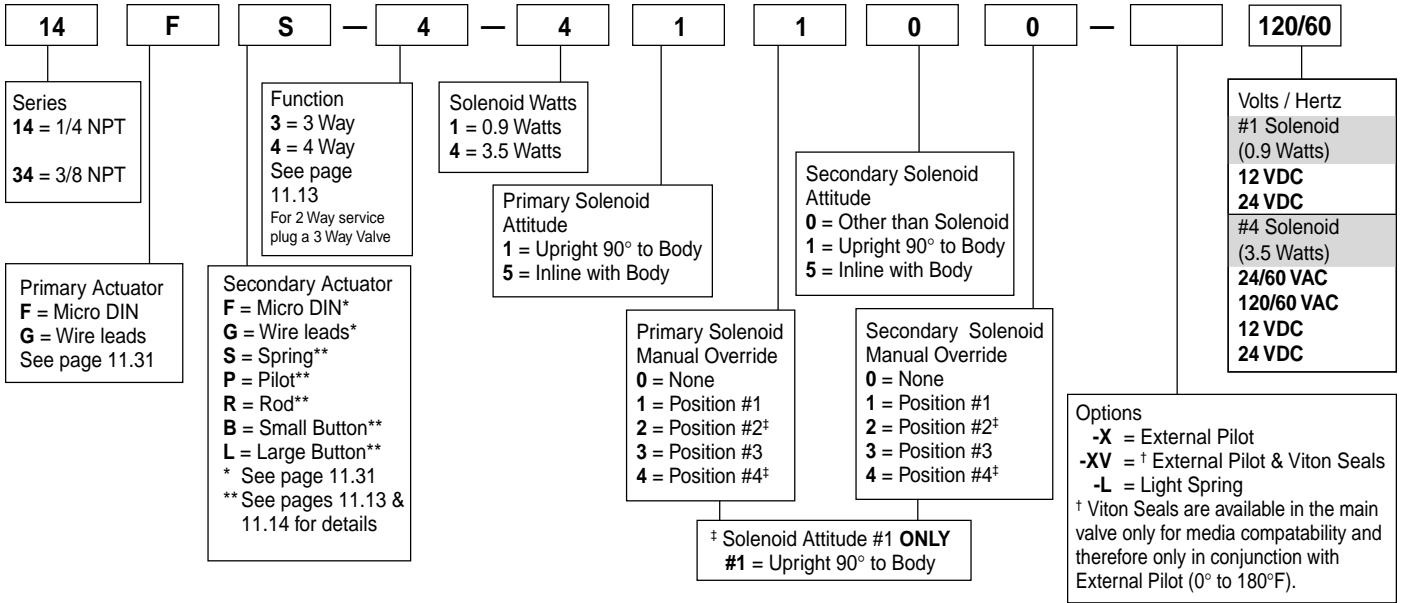

Example: 14FS-4-41100-120/60

1/4 NPT – Primary Actuator Solenoid with Micro DIN coil; Secondary Actuator, Spring Return – 4 Way Function 3.5 Watt Solenoid; Primary Solenoid Upright position with Manual Override in Position #1; Secondary Actuator is not a Solenoid; no Manual Override on Secondary Actuator – No Options – 120 Volt/60 Hertz.

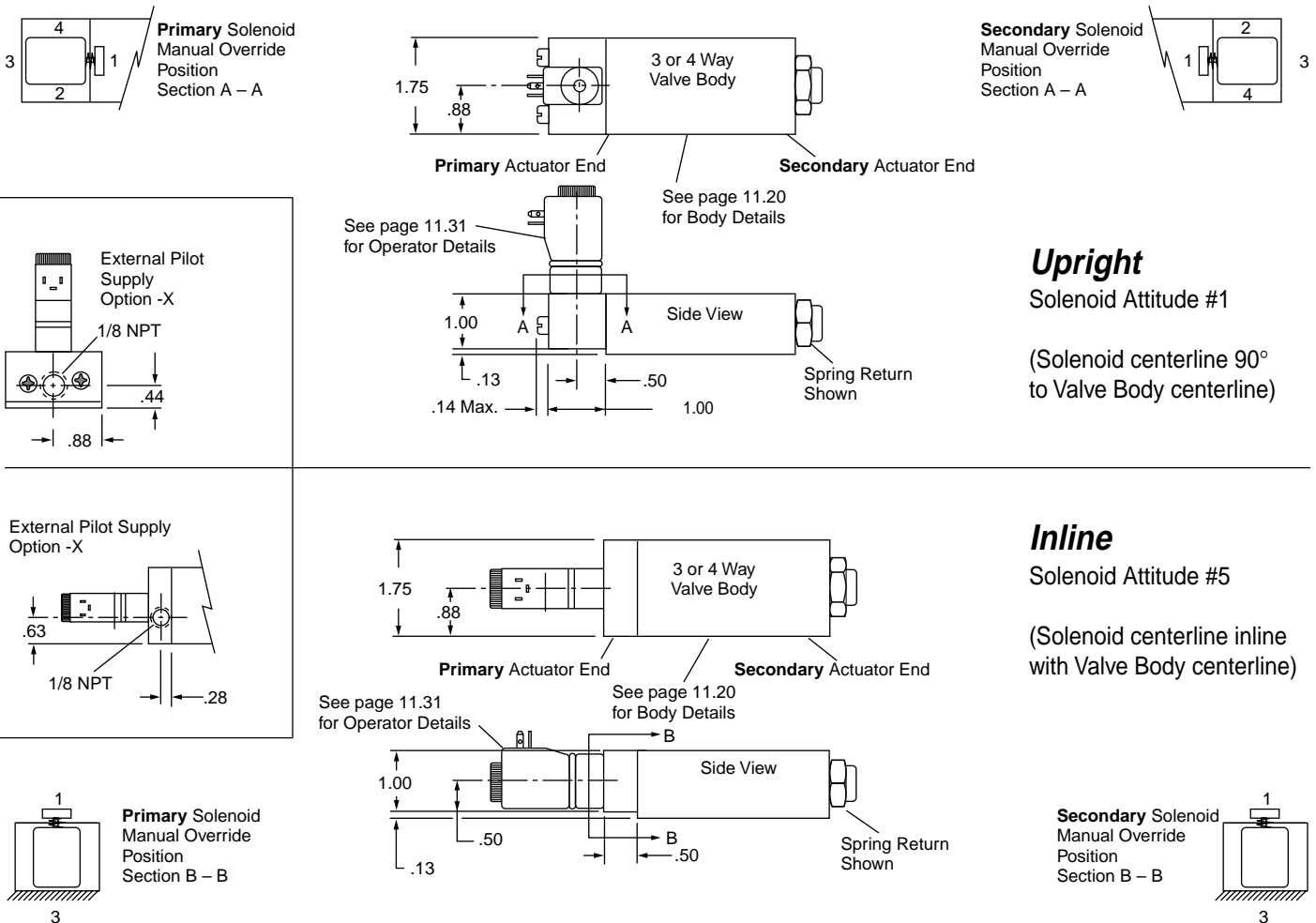

Directional Control Valves ^{3/8 & 1/2 NPT} 12, 12A, 12B & 38 Series

38 SERIES: 3/8 NPT Ported Air Valves
12, 12A & 12B SERIES: 1/2 NPT Ported Air Valves

2, 3 & 4 Way; 2 & 3 Position Operation to 150 psi
Note! Spring return & spring centered models NOT suitable for dry air service.

Features

- Direct ported 3/8 NPT, 1/2 NPT and 1/2 NPT high flow:
 2 & 3 Way - 2 Position.
 4 Way - 2 & 3 Position.
- Aluminum bar stock body and operator blocks, black anodized.
- Light weight aluminum spool, hard anodized for long life.
- Operator blocks field interchangeable.
- Buna N seals.
- Operating temperature (0° to + 180°F); solenoid controlled models +150° F max. See pages 11.25 & 11.26.
- All spool seals size checked to assure reliability.

- Single Subbase or multiple manifolds with 3/8 and 1/2 NPT ports for 4 Way - 2 & 3 Position see Pg 11.27.
- High flow factors, see Pg 11.27.
- Parts anodized for corrosion resistance.
- Aluminum end caps, anodized red, locate counterbores in body to control static squeeze on seals.
- Aluminum center cages, anodized gold, have lips to hold seals in place.

- Spool cushioned with Delrin®-Urethane bumper combination that absorbs shock but does not bounce the spool.
- Simple construction for easy servicing.
- Spool "Lands" double tapered and polished to assure easy entry into seal.
- Prelubed with Magnalube®-G grease.

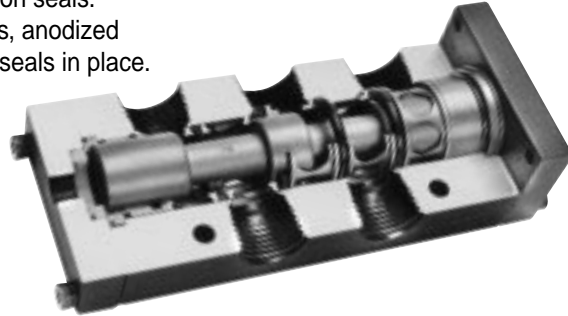

Catalog Options

- Manual Overrides for Piloted and Solenoid Valves
- External Pilot Supply for Solenoid Valve Option -X
- Explosion Proof Operators, Spade Coil Connections, and other Solenoid Coil choices - see Pg 11.29 - 11.32
- High Flow Body (see Model Charts)
- Service Kits
 2 or 3 Way - Seal Kit 12PV-903
 4 Way - Seal Kit 12PV-904
- Dual Inlet - Single Exhaust - 4 Way: See note below
- Mufflers for Solenoid Exhaust... SM-10, See page 14.4
- Other Operator Combinations
 Solenoid - Pilot Return
 Solenoid - Push-Pull Knob
 See Model Charts

Custom Options

- 10-32 Pilot Ports
- 10-32 Auxiliary Pressure Outlets
- Viton Seals
- Stacking and Manifolding to Customer requirements

Specials

Fabco-Air, Inc. has the expertise and willingness to design and modify these valves to your necessary and specific job requirements. Please advise us of your needs. See pages ii & iii

Spools

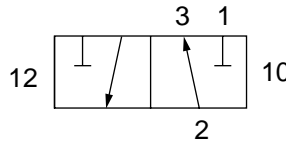

2-Way or 3 Way - 2 Position - Type 3

This 3 Way Valve may be used for any 2 Way, 3 Way, Selector or Diverter service. When used with internally supplied Solenoid Operators, the Supply Pressure must be connected to Port #1. For this same reason when a normally open Solenoid Valve is ordered the Solenoid Operator will be mounted on end 10 and the Spring on End 12.

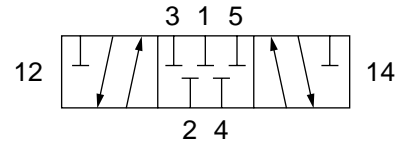

4-Way - 5 Ported - 3 Position - Type B

"Blocked"

Center position - All ports blocked and isolated. Use on conventional block and hold circuits.

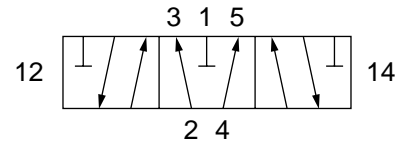

4-Way - 5 Ported - 3 Position - Type F

"Float"

Center position - Inlet blocked and Cylinders open to exhaust. Used to vent both ends of cylinder to allow cylinder to float with a manual or machine movement. Flow controls or exhaust speed controls should not be used.

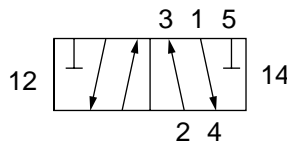

4-Way - 5 Ported - 2 Position - Type 2

Use on all 4 Way - 2 Position applications

Note: Any of these 4 Way Valves, except the internally supplied Solenoid Valves, (See Option -X) can be used as Dual Inlet, Single Exhaust. Using this concept, with different pressures for force application and retraction, can effect large savings of high pressure air and its cost. The larger the cylinder or the faster the cycle, the higher the savings.

Directional Control Valves ^{3/8 & 1/2} NPT 12, 12A, 12B & 38 Series

PILOT OPERATED

When Ordering:

Specify Model Number from chart. Specify Options.
(See page 11.27 & 11.28 for Dimensional Information.)



OPERATING RANGE:

Inlet Pressure 0 - 150 psi
Pilot Pressure:

Models without Spring 10 - 150 psi
2 Position Standard Service Spring 45 - 150 psi
2 Position Light Service Spring (Option -L) .. 30 - 150 psi
3 Position, Spring Centered 30 - 150 psi

Optional Manual Overrides	Model Suffix
LOCKING	-MO1
LOCKS IN - Does not lock OUT	-MO2
Does not lock IN - LOCKS OUT	-MO3
NON-LOCKING	-MO4

		Direct Ported			SUBBASE OR MANIFOLD MOUNTED See pg 11.27 and Specify
		3/8 NPT	1/2 NPT	1/2 NPT High Flow	
2 Position					
Single Pilot Spring Return	2 Way - 3 Way 4 Way	383-SP 38-SP	123-SP 12-SP	123B-SP 12B-SP	NA 12A-SP
Double Pilot	2 Way - 3 Way 4 Way	383-DP 38-DP	123-DP 12-DP	123B-DP 12B-DP	N 12A-DP
3 Position					
Double Pilot Type B Spool	4 Way	38-DPB	12-DPB	NA	12A-DPB
Double Pilot Type F Spool	4 Way	38-DPF	12-DPF	NA	12A-DPF

HAND LEVER OPERATED

When Ordering:

Specify Model Number from chart. Specify Options.
(See page 11.27 & 11.28 for Dimensional Information.)



OPERATING RANGE: 0 - 150 psi

		Direct Ported			SUBBASE OR MANIFOLD MOUNTED See pg 11.27 and Specify
		3/8 NPT	1/2 NPT	1/2 NPT High Flow	
2 Position					
Spring Return	2 Way - 3 Way 4 Way	383-HLS 38-HLS	123-HLS 12-HLS	123B-HLS 12B-HLS	NA 12A-HLS
Detented	2 Way - 3 Way 4 Way	383-HL 38-HL	123-HL 12-HL	123B-HL 12B-HL	N 12A-HL
3 Position					
Spring Centered Type B Spool	4 Way	38-HLSB	12-HLSB	NA	12A-HLSB
Spring Centered Type F Spool	4 Way	38-HLSF	12-HLSF	NA	12A-HLSF
Detented Type B Spool	4 Way	38-HLB	12-HLB	NA	12A-HLB
Detented Type F Spool	4 Way	38-HLF	12-HLF	NA	12A-HLF

PUSH-PULL KNOB OPERATED

When Ordering:

Specify Model Number from chart. Specify Options.
(See page 11.27 & 11.28 for Dimensional Information.)



OPERATING RANGE: 0 - 150 psi
Standard knob color is black.
For red knob add suffix -R to Model Number.

		Direct Ported			SUBBASE OR MANIFOLD MOUNTED See pg 11.27 and Specify
		3/8 NPT	1/2 NPT	1/2 NPT High Flow	
2 Position					
Push - Pull (Natural Detent)	2 Way - 3 Way 4 Way	383-PO 38-PO	123-PO 12-PO	123B-PO 12B-PO	NA 12A-PO
Push Spring Return	2 Way - 3 Way 4 Way	383-PS 38-PS	123-PS 12-PS	123B-PS 12B-PS	NA 12A-PS
Push Pilot Return	2 Way - 3 Way 4 Way	383-PA 38-PA	123-PA 12-PA	123B-PA 12B-PA	NA 12A-PA
Push - Push Knob Both Ends	2 Way - 3 Way 4 Way	383-PP 38-PP	123-PP 12-PP	123B-PP 12B-PP	NA 12A-PP
3 Position					
Push - Pull Spring Centered Type B Spool	4 Way	38-PB	12-PB	NA	12A-PB
Push - Push Spring Centered Knob Both ends Type B Spool	4 Way	38-PPB	12-PPB	NA	12A-PPB
Push - Pull Spring Centered Type F Spool	4 Way	38-PF	12-PF	NA	12A-PF
Push - Push Spring Centered Knob Both ends Type F Spool	4 Way	38-PPF	12-PPF	NA	12A-PPF

Directional Control Valves ^{3/8 & 1/2} NPT 12, 12A, 12B & 38 Series

3/8 & 1/2 NPT Ported, 53 STYLE Solenoid Controlled, Pilot Operated Air Valves 2 Way, 3 Way - 2 Position — 4 Way 2 or 3 Position — Operation to 150 PSI Air

See pages 11.27 & 11.28 for dimensional information.



When Ordering:
Specify Model Number from Chart
Specify Options
Specify Volts / Hertz
See pages 11.29 & 11.30 for Solenoid Operator,
Coil and Housing information.

Operating Temperature:
0°F (-18°C) to +104°F (40°C) ambient.
0°F (-18°C) to +150°F (65°C) media.

Operating Ranges, psi

Internal Pilot Supply (Standard) Inlet Pressure
No Spring 10 to 150
Spring: 2 Position 45 to 150
2 Position Light Service Spring,
Option -L 30 to 150
3 Position 30 to 150
External Pilot Supply, Option -X:
Inlet Pressure 0 to 150
Pilot Pressure, Same as Internal Pilot Supply above.

Optional Manual Overrides	Model Suffix
LOCKING	-MO1
LOCKS IN - Does not lock OUT	-MO2
Does not lock IN - LOCKS OUT	-MO3
NON-LOCKING	-MO4

Conduit Housing "C"

		3/8 NPT	1/2 NPT	1/2NPT High Flow	Sub-base/Manifold, See Pg. 11.27
2 Position					
Single Solenoid Spring Return	2 / 3 Way, NC 2 / 3 Way, NO 4 Way	383-CS 3830-CS 38-CS	123-CS 1230-CS 12-CS	123B-CS 1230B-CS 12B-CS	NA NA 12A-CS
Single Solenoid Pilot Return	2 / 3 Way 4 Way	383-CA 38-CA	123-CA 12-CA	123B-CA 12B-CA	NA 12A-CA
Single Solenoid Knob Return	2 / 3 Way 4Way	383-CP 38-CP	123-CP 12-CP	123B-CP 12B-CP	NA 12A-CP
Double Solenoid	2 / 3 Way 4 Way	383-CC 38-CC	123-CC 12-CC	123B-CC 12B-CC	NA 12A-CC
3 Position					
Solenoid – Pilot, B Spool	4 Way	38-CAB	12-CAB	NA	12A-CAB
Solenoid – Pilot, F Spool	4 Way	38-CAF	12-CAF	NA	12A-CAF
Double Solenoid – B Spool	4 Way	38-CCB	12-CCB	NA	12A-CCB
Double Solenoid – F Spool	4 Way	38-CCF	12-CCF	NA	12A-CCF

Grommet Housing "G"

		3/8 NPT	1/2 NPT	1/2NPT High Flow	Sub-base/Manifold, See Pg. 11.27
2 Position					
Single Solenoid Spring Return	2 / 3 Way, NC 2 / 3 Way, NO 4 Way	383-GS 3830-GS 38-GS	123-GS 1230-GS 12-GS	123B-GS 1230B-GS 12B-GS	NA NA 12A-GS
Single Solenoid Pilot Return	2 / 3 Way 4 Way	383-GA 38-GA	123-GA 12-GA	123B-GA 12B-GA	NA 12A-GA
Single Solenoid Knob Return	2 / 3 Way 4Way	383-GP 38-GP	123-GP 12-GP	123B-GP 12B-GP	NA 12A-GP
Double Solenoid	2 / 3 Way 4 Way	383-GG 38-GG	123-GG 12-GG	123B-GG 12B-GG	NA 12A-GG
3 Position					
Solenoid – Pilot, B Spool	4 Way	38-GAB	12-GAB	NA	12A-GAB
Solenoid – Pilot, F Spool	4 Way	38-GAF	12-GAF	NA	12A-GAF
Double Solenoid – B Spool	4 Way	38-GGB	12-GGB	NA	12A-GGB
Double Solenoid – F Spool	4 Way	38-GGF	12-GGF	NA	12A-GGF

Male Mini-DIN Housing "F"

		3/8 NPT	1/2 NPT	1/2NPT High Flow	Sub-base/Manifold, See Pg. 11.27
2 Position					
Single Solenoid Spring Return	2 / 3 Way, NC 2 / 3 Way, NO 4 Way	383-FS 3830-FS 38-FS	123-FS 1230-FS 12-FS	123B-FS 1230B-FS 12B-FS	NA NA 12A-FS
Single Solenoid Pilot Return	2 / 3 Way 4 Way	383-FA 38-FA	123-FA 12-FA	123B-FA 12B-FA	NA 12A-FA
Single Solenoid Knob Return	2 / 3 Way 4Way	383-FP 38-FP	123-FP 12-FP	123B-FP 12B-FP	NA 12A-FP
Double Solenoid	2 / 3 Way 4 Way	383-FF 38-FF	123-FF 12-FF	123B-FF 12B-FF	NA 12A-FF
3 Position					
Solenoid – Pilot, B Spool	4 Way	38-FAB	12-FAB	NA	12A-FAB
Solenoid – Pilot, F Spool	4 Way	38-FAF	12-FAF	NA	12A-FAF
Double Solenoid – B Spool	4 Way	38-FFB	12-FFB	NA	12A-FFB
Double Solenoid – F Spool	4 Way	38-FFF	12-FFF	NA	12A-FFF

Directional Control Valves ^{3/8 & 1/2} NPT 12, 12A, 12B & 38 Series

3/8 & 1/2 NPT Ported, 58 STYLE Solenoid Controlled, Pilot Operated Air Valves
2 Way, 3 Way - 2 Position — 4 Way 2 or 3 Position

Spring Return and Spring Centered Models NOT suitable for dry air service

See pages 11.27 & 11.28 for other dimensional information, 11.31 for solenoid information.



Operating Temperature:
 -5°F (-15°C) to +122°F (50°C) ambient.
 -5°F (-15°C) to +122°F (50°C) media.

Operating Ranges, psi

	#1 Solenoid 0.9 Watts	#4 Solenoid 3.5 Watts
Internal Pilot Supply (Standard) Inlet Pressure		
No Spring:	10 to 130 . . .	10 to 145
Spring: 2 Position	45 to 130 . . .	45 to 145
2 Position Light Service Spring, Option -L	30 to 130 . . .	30 to 145
3 Position	30 to 130 . . .	30 to 145
External Pilot Supply, Option -X:		
Inlet Pressure	0 to 150	0 to 150
Pilot Pressure, Same as Internal Pilot Supply above.		

58 STYLE Solenoid Valve, Model Number Code

12	F	S	-	4	5	1	0	0	-	120/60
Primary Actuator F = Micro DIN G = Wire leads See page 11.31	Secondary Actuator F = Micro DIN, 2 Pos.* FB = Micro DIN 3 Position Type B* FF = Micro DIN 3 Position Type F* G = Wire leads, 2 Pos.* GB = Wire leads 3 Position Type B* GF = Wire leads 3 Position Type F* S = Spring** A = Pilot** P = Knob (Black)** PR = Knob (Red)** * See page 11.23, 11.31. ** See pages 11.24 & 11.28 for details.	Solenoid Watts 1 = 0.9 Watts 4 = 3.5 Watts	Primary Solenoid Attitude 5 = Inline with Body	Secondary Solenoid Attitude 0 = Other than Solenoid 5 = Inline with Body	Primary Solenoid Manual Override 0 = None 1 = Position #1 2 = Position #2 3 = Position #3 4 = Position #4	Secondary Solenoid Manual Override 0 = None 1 = Position #1 2 = Position #2 3 = Position #3 4 = Position #4	Options -X = External Pilot -XV = † External Pilot & Viton Seals -L = Light Spring † Viton Seals are available in the main valve only for media compatibility and therefore only in conjunction with External Pilot [-5°F (-15°C) to +122°F (50°C)].		Volts / Hertz #1 Solenoid (0.9 Watts) 12 VDC, 24 VDC #4 Solenoid (3.5 Watts) 24/60 VAC 120/60 VAC 12 VDC 24 VDC	

Series:

38	= 3/8 NPT, 4 Way
383	= 3/8 NPT, 3 Way NC
3830	= 3/8 NPT, 3 Way NO
12	= 1/2 NPT, 4 Way
123	= 1/2 NPT, 3 Way NC
1230	= 1/2 NPT, 3 Way NO
12A	= 4 Way, Subbase Mount
12B	= 1/2 NPT, 4 Way, 2 Position High Flow
123B	= 1/2 NPT, 3 Way NC, High Flow
1230B	= 1/2 NPT, 3 Way NO, High Flow

Example: 12FS-45100-120/60

1/2 NPT, 4 Way – Primary Actuator Solenoid with Micro DIN coil; Secondary Actuator, Spring Return – 3.5 Watt; Primary Solenoid Inline Attitude with Manual Override on Primary Solenoid in Position #1; Secondary Actuator is not a Solenoid; no Manual Override on Secondary Actuator – No Options – 120 Volt/60 Hertz.

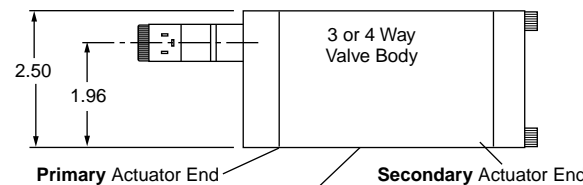
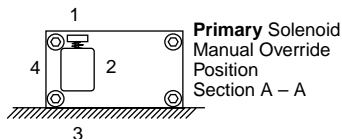
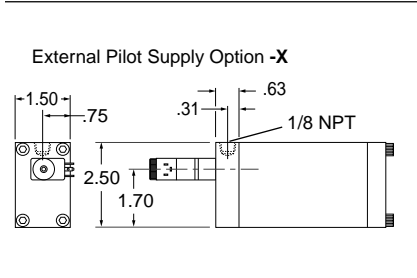

See page 11.31 for Operator Details
 See page 11.27 for Body Details

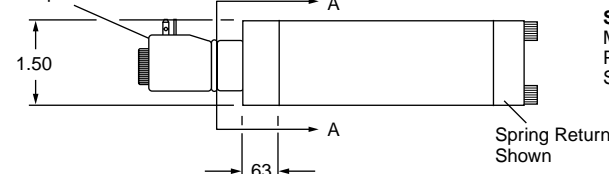

Inline Solenoid Attitude #5

(Solenoid centerline inline with Valve Body centerline)

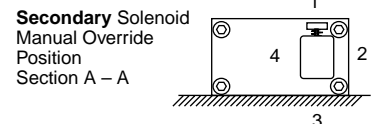

Directional Control Valves

3/8 & 1/2 NPT 12, 12A, 12B & 38 Series

BASIC BODIES

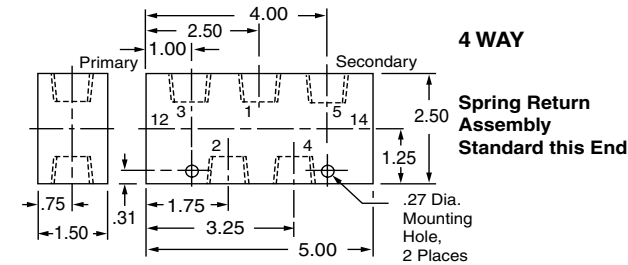
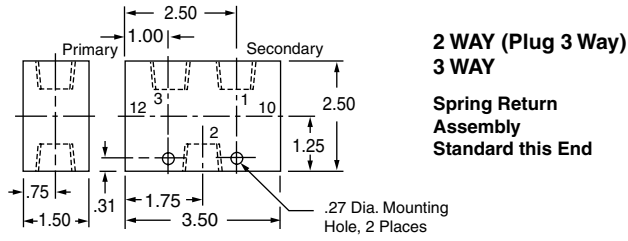

Cv FLOW FACTORS

		Direct Ported		Subbase Mounted Side or Bottom Ported	
		3/8 or 1/2 NPT	1/2 NPT High Flow	3/8 NPT	1/2 NPT
2-Way - 3-Way 2 Position - Type 3 Spool		4.1	6.2	NA	NA
4-Way 2 Position - Type 2 Spool		4.1	6.2	3.1	3.7
4 Way 3 Position	Type B Spool	2.4	NA	2.2	2.4
	Type F Spool				
	Shifted 1 to 2; 1 to 4	2.4	NA	2.2	2.3
	Shifted 2 to 3; 4 to 5	4.1	NA	3.4	3.9
	Centered 2 to 3; 4 to 5	2.7	NA	2.6	2.8

NOTE: Any of these 4-way valves, except the internally supplied solenoid valves (see Option -X), can be used as dual inlet, single exhaust. Using this concept, with different pressures for force application and retraction, can effect large savings of high pressure air and its cost. The larger the cylinder or the faster the cycle, the higher the savings.

SINGLE SUBBASES

To Order
Specify Valve Model No. (See pages 11.23 - 11.26)
Specify Subbase Part No. listed below.
EXAMPLE - Photo shows 12A-SP-MO4 with 12 PV-50

SIDE PORTED
3/8 NPT Ports Specify **38 PV-50**
1/2 NPT Ports Specify **12 PV-50**

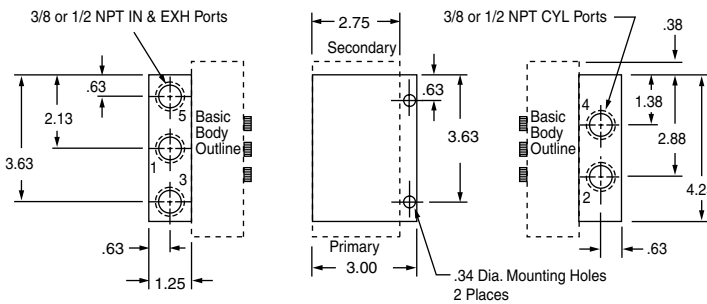

MOUNT 4 WAY VALVE WITH ANY OPERATOR



BOTTOM PORTED
3/8 NPT Ports Specify **38 PV-51**
1/2 NPT Ports Specify **12 PV-51**

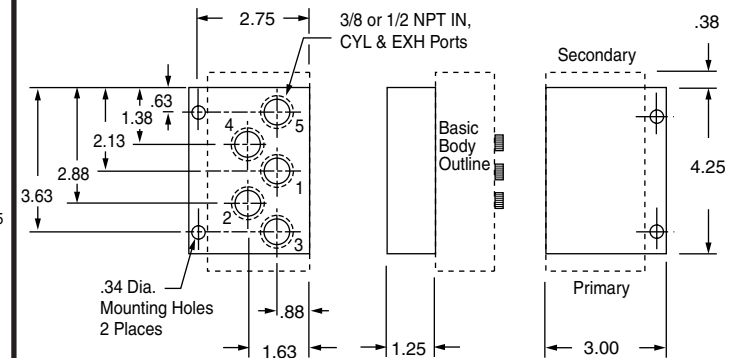

11

MULTIPLE MANIFOLDS

To Order
Specify Station No. - Valve Model - Manifold Number
EXAMPLE - Photo shows one unit consisting of 3 valves and manifolds:
Sta. No. 1 12A-CS-MO1 with 12 PV-65
Sta. No. 2 12A-DP with 12 PV-66
Sta. No. 3 12A-HL with 38 PV-65

MOUNT ANY COMBINATION OF 4 WAY VALVE MODELS & PORT SIZES

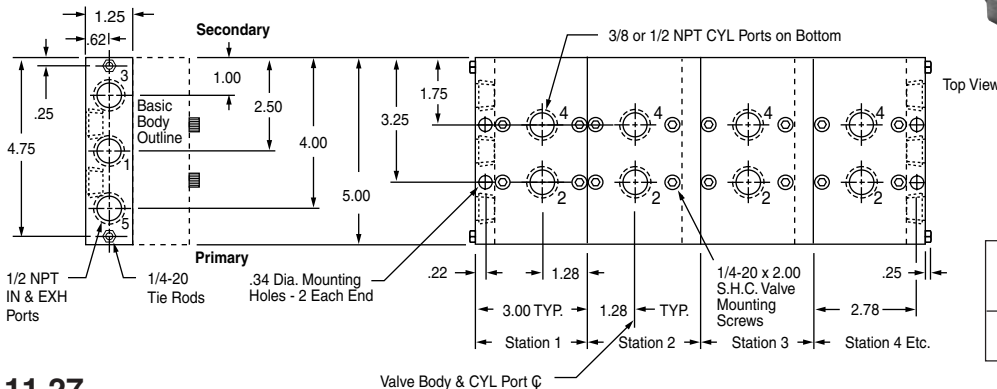
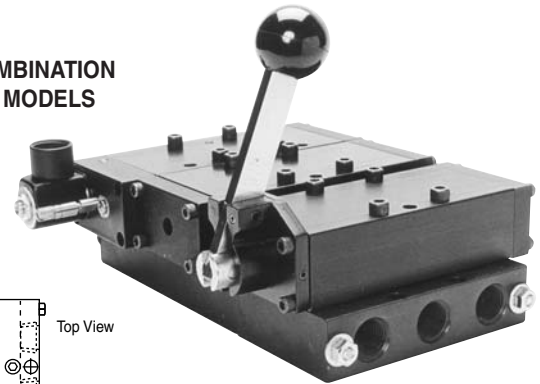

	CYLINDER PORTS	
	3/8 NPT	1/2 NPT
End Unit 1/2 NPT IN & EXH	38 PV-65	12 PV-65
CENTER UNIT	38 PV-66	12 PV-66

11.27

Directional Control Valves ^{3/8 & 1/2 NPT} 12, 12A, 12B & 38 Series

AIR PILOT OPERATOR

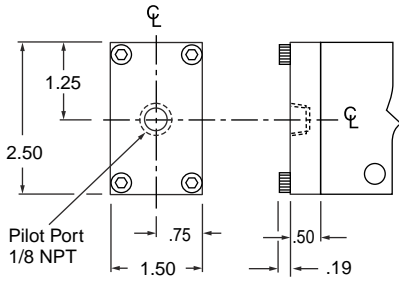

AIR PILOT OPERATOR with Manual Override

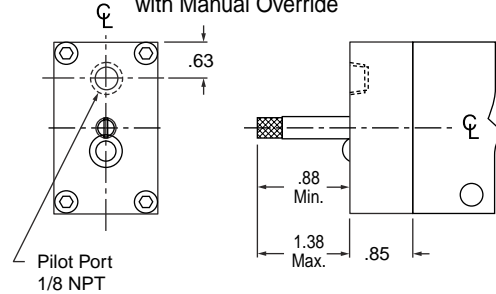

2 Position, Spring return
Dimensions shown at the
bottom of the page.

3 Position Spring Centering
is incorporated within the
operator dimensions.

Manual Overrides applicable to Pilot Operated or 53 Style Solenoid Operated Valves	To Specify Add Suffix to Model Number
LOCKING	-MO1
LOCKS IN - Does not lock OUT	-MO2
Does not lock IN - LOCKS OUT	-MO3
NON-LOCKING	-MO4

Note: The manual override stem physically contacts and moves the spool.

The **53 STYLE** solenoid operator is a 3-way valve which, upon receiving an electrical signal, directs a pilot pressure to shift the main valve spool. Unless otherwise specified, the operator is internally supplied from the main valve inlet with pressure for piloting. If an external pilot supply is required specify Suffix **-X** after the model number. This external pilot supply may be required; where the media through the main valve is of insufficient pressure for piloting, where the media through the main valve is something other than compressed air, for 4-way dual inlet-single exhaust, or other applications.

53 STYLE SOLENOID OPERATOR

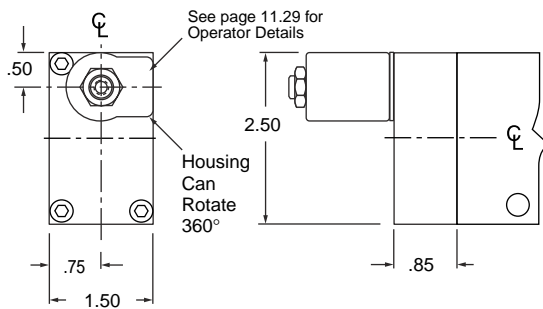

53 STYLE SOLENOID OPERATOR

with Manual Override and External Pilot Supply, Option **-X**

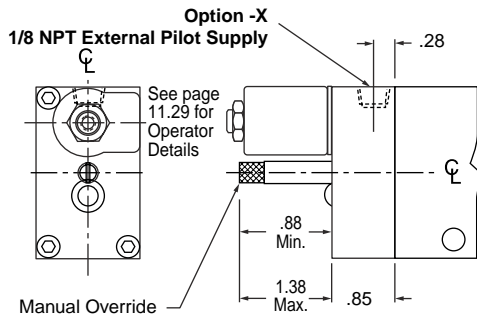

2 Position, Spring return
Dimensions shown at the
bottom of the page.

3 Position Spring Centering
is incorporated within the
operator dimensions.

58 STYLE Solenoid Operator – See page 11.26

HAND LEVER OPERATOR

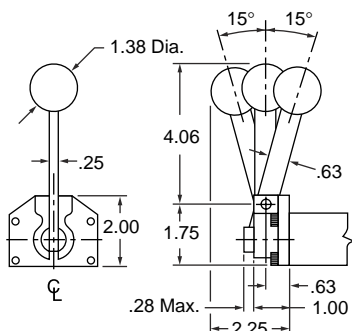

3 POSITION SPRING CENTERING OPERATOR FOR HAND LEVER ONLY

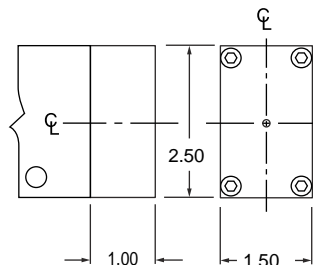

PALM BUTTON OPERATOR

2 Position, Spring return
Dimensions shown to right.
3 Position Spring Centering
is incorporated within the
operator dimensions.

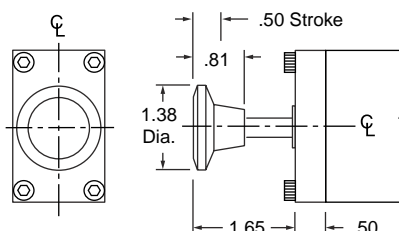

2 POSITION SPRING RETURN, STANDARD & LIGHT SERVICE

All valve models –
Standard service
spring consists of two
concentric helical springs.
Either may be removed
for "Light" Service.

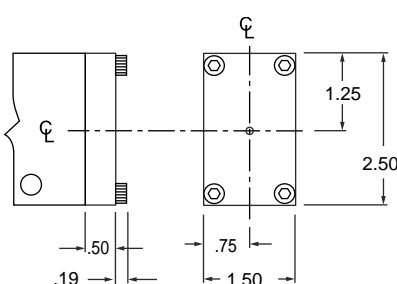

53 STYLE Stocked Coils and Housings

Conduit Housing "C" and Grommet Housing "G"

Non-molded – Class A 221°F (105°C) Rating,
24" Leads of AWG #18 Wire.

Stocked Voltages:

24, 120 and 240 Volt at 50 or 60 Hertz;
6, 12 and 24 Volt DC;
Others available, see Options on page 11.30.

Temperature Range:

0°F (-18°C) to + 104°F (+40°C), ambient.
0°F (-18°C) to + 150°F (+65°C), media.

Typical Response Times:

AC 4 to 8 milliseconds to open or close;
DC 9 to 15 milliseconds to open;
DC 5 to 12 milliseconds to close.

To compute current requirements (±15%) divide factor shown below by voltage

Function	AC Volts, 60 Hertz		DC Volts
	Inrush, Amp	Holding, Amp	Inrush, Amp or Holding, Amp
2 Way NC	13.2 ÷ Volts	7.8 ÷ Volts	7.2 ÷ Volts
2 Way NO 3 Way NC or NO	15.2 ÷ Volts	9.0 ÷ Volts	
Examples	15.2 ÷ 120 = .13 Amp	9.0 ÷ 120 = .08 Amp	7.2 ÷ 12 = .60 Amp

Male Mini-DIN Housing "F"

Molded – Water Tight - Class A 221°F (105°C) Coil Rating.
European (DIN) Style – 11 mm spacing.

See page 11.30 for connectors or contact your
local distributor for additional choices.

Can also be connected with individual .25" quick connect terminals.

Stocked Voltages:

24, 120 and 240 Volt at 50 or 60 Hertz;
12 and 24 Volt DC;
Others available, see Options on page 11.30.

Temperature Range:

0°F (-18°C) to + 104°F (+40°C), ambient.
0°F (-18°C) to + 150°F (+65°C), media.

Typical Response Times:

AC 4 to 8 milliseconds to open or close;
DC 9 to 15 milliseconds to open;
DC 5 to 12 milliseconds to close.

To compute current requirements (±15%) divide factor shown below by voltage.

Function	AC Volts, 60 Hertz		DC Volts
	Inrush, Amp	Holding, Amp	Inrush, Amp or Holding, Amp
2 Way NC	14.4 ÷ Volts	9.7 ÷ Volts	10.4 ÷ Volts
2 Way NO 3 Way NC or NO	15.2 ÷ Volts	11.8 ÷ Volts	10.4 ÷ Volts
Examples	15.2 ÷ 120 = .13 Amp	11.8 ÷ 120 = .10 Amp	10.4 ÷ 12 = .87 Amp

Conduit Housing "C"

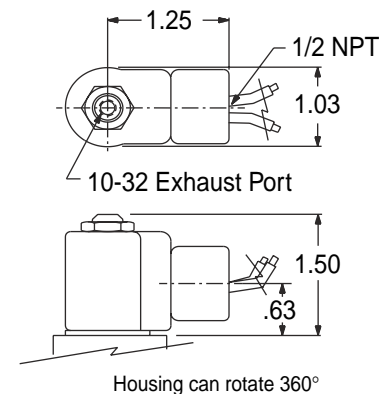

Grommet Housing "G"

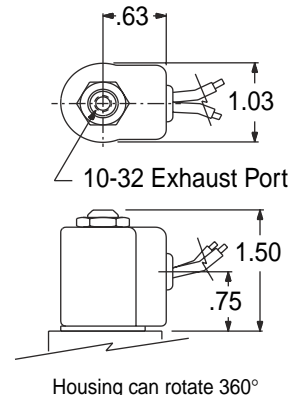

Male Mini-DIN Housing "F"

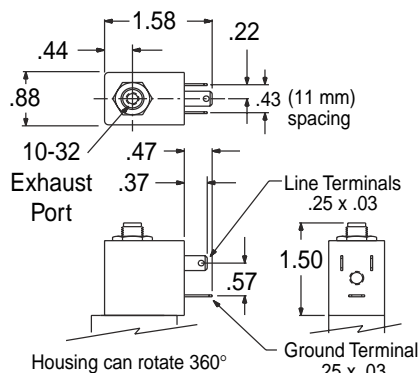

Spade terminals accept miniature rectangular quick connect socket (Female DIN style connector, 11 mm spacing) or individual .25" quick connect terminals.

Options for 53 STYLE Solenoids

For **Conduit Housing "C"** and **Grommet Housing "G"**:

- AC Voltages from 5.4 to 575 in 50 or 60 Hertz.
- DC Voltages from 3 to 300.
- Molded Coil, Option **-M**
Water tight, Molded Coil with Class A 221°F (105°C) Rating. Coil is completely molded in epoxy for maximum moisture resistance. NEMA 1, 2, and 3 when in Conduit "C", or Grommet "G" housing.
- Potted Coil, Option **-P**
Coil is epoxy potted into Conduit "C" housing only. Class F 221°F (105C) Rating. It offers maximum moisture and vibration resistance. NEMA 3R, 3S, 4, 4X, 6, 11, 12 & 13.
- High Temperature Option **-H**
Molded coil with 356°F (180°C) rating.
- Viton Seals Option **-V** (for media compatibility)
- Strain Relief Connector Option **-Q**
- "AN" Connector Option **-W**
- Splice Box Option **-J**
- Mounting Bracket Option **-R**
- Third Wire Ground Option **-CC**
A CSA requirement.

Options for 53 STYLE Solenoids

For **Male Mini-DIN Housing "F"**:

- AC Voltages from 4.4 to 277 in 50 or 60 Hertz.
- DC Voltages from 3 to 180.
- Viton Seals Option **-V** (for media compatibility)

- Yoke with Standard coil (24" flying leads) Option **-YB**
- Yoke with Molded coil (24" flying leads) Option **-YM**
- Yoke with Molded Spade Terminal and coil Option **-KM**

Yoke replaces housing for protected and control box applications. Molded coil with two .25" spade terminals for quick assembly and disconnect.

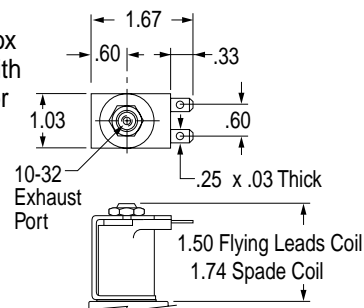

- Explosion Proof Option **-EP**

UL File #E37780
CSA File #LR-26894
For hazardous locations, includes Molded Coil.
UL Class I Div. 1 Groups C & D.
UL Class II Div. 1 Groups E, F & G.
UL Class II Div. 2 Groups A, B, C, D, E & F.
NEMA 7 Class 1 Group D.
NEMA 9 & 9A Class II Groups F & G.

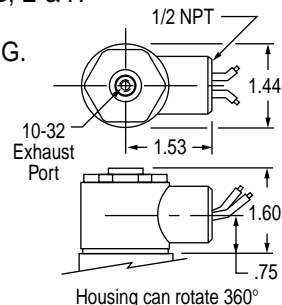

! CAUTION !
To prevent explosion, disconnect electrical circuit before opening enclosure! Keep tightly closed when in operation.

Option -EP Current Factors

AC Volts, 60 Hertz	Inrush	Holding
2 Way NC	16.0	7.8
2 Way NO	16.9	10.7
3 Way NC or NO	16.9	10.7
DC Volts	Inrush or Holding	
2 Way NC or NO	7.2	
3 Way NC or NO	7.2	

Divide "Factor" shown above by Volts to find current. See examples on opposite page.

Accessories for 53 STYLE Solenoids

For **Conduit Housing "C"** and **Grommet Housing "G"**:

- Solenoid Exhaust Mufflers, SM-10 See page 14.4.

For **Male Mini-DIN Housing "F"**:

- Connectors (11 mm spacing)

Part Number without LED: **122-09-N**
Black Housing

Part Number with LED: **122-09-T-A.1-Voltage**
Available in 12, 24, 120, or 240 Volt; AC or DC only.
(Transparent Housing allows LED to be seen)

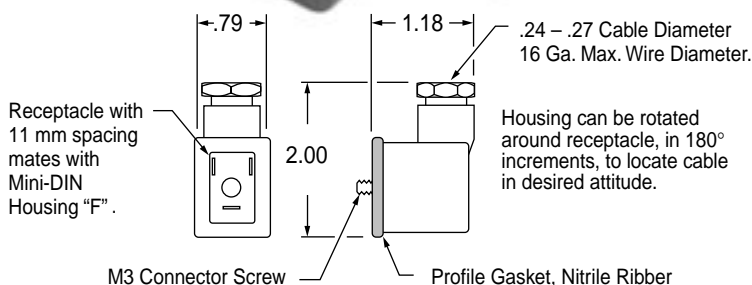

58 Style #1 Operator

0.9 Watts
 Volts – 12 VDC . . . 24 VDC
 Amperage Draw – (approximate) . . 73 mA . . . 37 mA
 3 Way – Normally Closed – Exhaust to Atmosphere
 0.6 mm Inlet Orifice – 0.8 mm Exhaust Orifice
 130 psi Maximum Operating Pressure
 Temperature Range:
 –5°F (–15°C) to + 122°F (+50°C), ambient.
 –5°F (–15°C) to + 122°F (+50°C), media.
 Response time: 9 ms @ 0 psi
 Available with or without Push Button Manual Override

Male Micro-DIN, Coil “F”

Molded – Water Tight - Class A 221°F (105°C) Coil Rating
 European (DIN) Style – 9.4 mm spacing
 See page 11.32 for connectors or contact your
 local distributor for additional choices.

Wire Leads, Coil “G”

Molded – Water Tight - Class A 221°F (105°C) Coil Rating
 Leadwires – AWG #20, 18 inches long

58 Style #4 Operator

3.5 Watts
 Volts – See Chart at Right
 Amperage Draw – See Chart at Right
 3 Way – Normally Closed – Exhaust to Atmosphere
 1.0 mm Inlet Orifice – 1.0 mm Exhaust Orifice
 145 psi Maximum Operating Pressure
 Temperature Range:
 –5°F (–15°C) to + 122°F (+50°C), ambient.
 –5°F (–15°C) to + 122°F (+50°C), media.
 Response time: 8 ms with DC Volts;
 3 – 9 ms with AC Volts.
 Available with or without Push Button Manual Override

Volts	Hertz	Amperage Draw, mA	
		Inrush	Holding
24	60	252	220
120	60	43	37
12	DC	294	294
24	DC	145	145

Male Micro-DIN, Coil “F”

Molded – Water Tight - Class A 221°F (105°C) Coil Rating
 European (DIN) Style – 9.4 mm spacing
 See page 11.32 for connectors or contact your
 local distributor for additional choices.

Wire Leads, Coil “G”

Molded – Water Tight - Class A 221°F (105°C) Coil Rating
 Leadwires – AWG #20, 18 inches long

58 Style

[#1 (0.9 Watts), or #4 (3.5 Watts)] Operator with Male Micro-DIN Coil "F" and without Manual Operator.

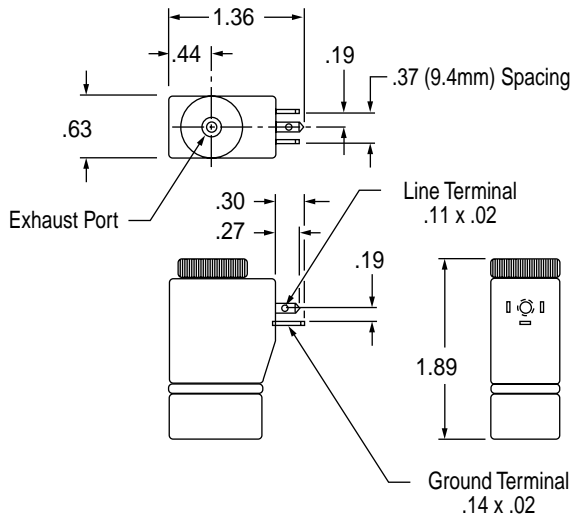

58 Style

[#1 (0.9 Watts), or #4 (3.5 Watts)] Operator with Male Micro-DIN Coil "F" and with Manual Operator.

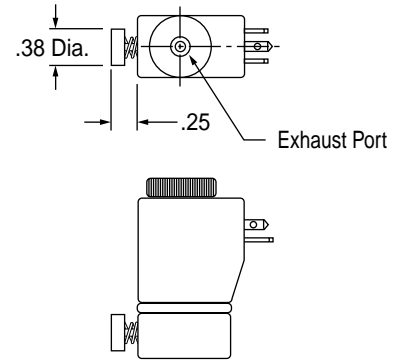

58 Style

[#1 (0.9 Watts), or #4 (3.5 Watts)] Operator with Leadwire Coil "G" and without Manual Operator.

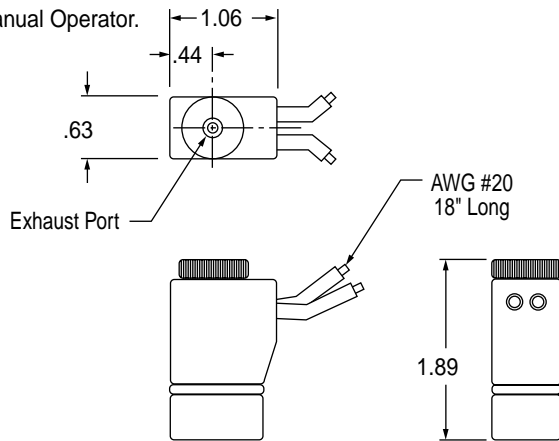

58 Style

[#1 (0.9 Watts), or #4 (3.5 Watts)] Operator with Leadwire Coil "G" and with Manual Operator.

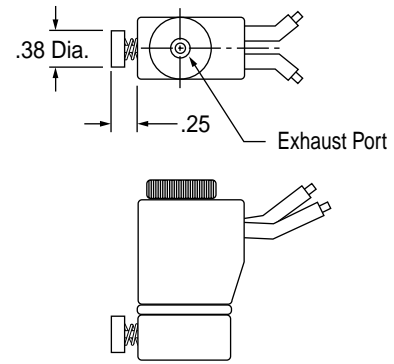

Connectors

(9.4 mm Spacing)

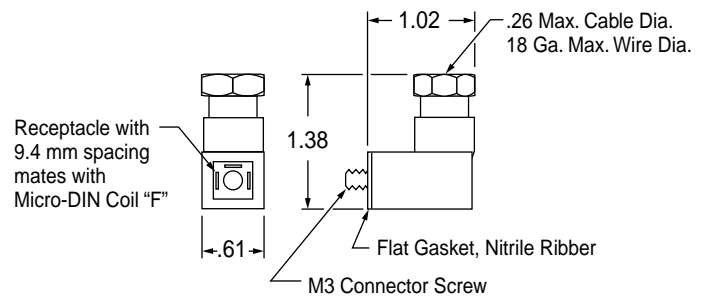

Part Number without LED: **192-07-N**
Black Housing

Part Number with LED: **192-07-T-A.1-Voltage**
Available in 12 or 24 Volt, AC or DC only.
(Transparent Housing allows LED to be seen)

Housing can rotate around receptacle, in 90° increments, to locate cable in desired attitude.