

CHECK VALVE BENDIX 00287298
PURGE VALVE BENDIX 00287053
DESSICANT CARTRIDGE - TURN IN OLD ONE



Service Data

SD-01-337

Bendix® TU-FLO® 501 Air Compressor

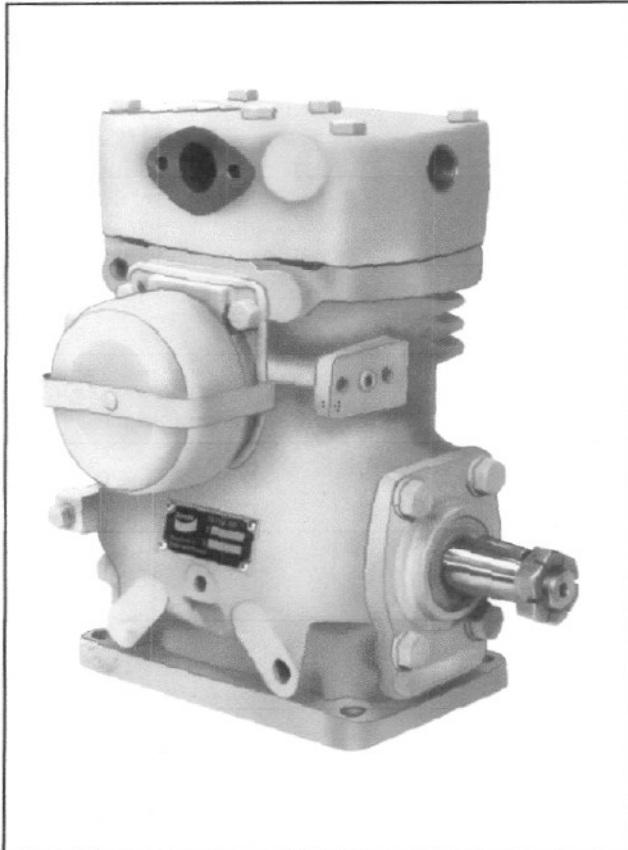

DESCRIPTION AND OPERATION

General

The function of the air compressor is to provide and maintain air under pressure to operate devices in the air brake and/or auxiliary air systems.

Description

The Tu-Flo® 501 compressor is a two cylinder, single stage, reciprocating compressor with a rated displacement of 12 cubic feet of air per minute at 1250 R.P.M.

The Tu-Flo® 501 compressor is constructed from two major assemblies, the head and the crankcase. The head houses the discharge valving and is installed on the upper portion of the crankcase. The crankcase is a one piece casting combining the cylinder block and the crankcase. The upper portion of the casting houses the cylinder bores and inlet valving; and the lower portion, the crankshaft and main bearings. Various mounting and drive configurations, required by the numerous vehicle engine designs, are obtained by bolting different mounting flanges, end covers, and base adapters to the crankcase. Two horizontal governor mounting pads are located on either side of the upper portion of the crankcase to provide convenient governor mounting.

Two methods are employed for cooling the Tu-Flo® 501 compressor during operation. The cylinder head is connected to the engine's cooling system, while the cylinder bore portion of the crankcase has external fins for efficient air cooling.

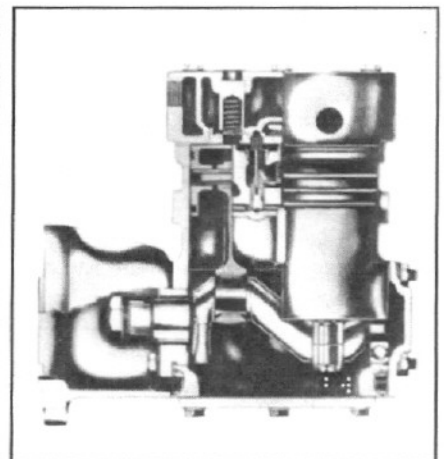
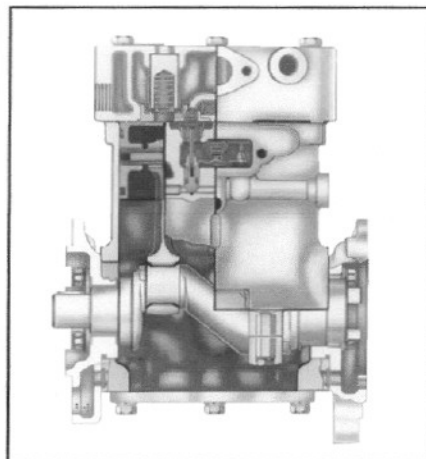
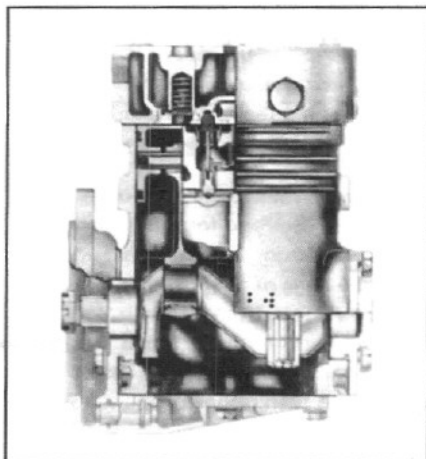

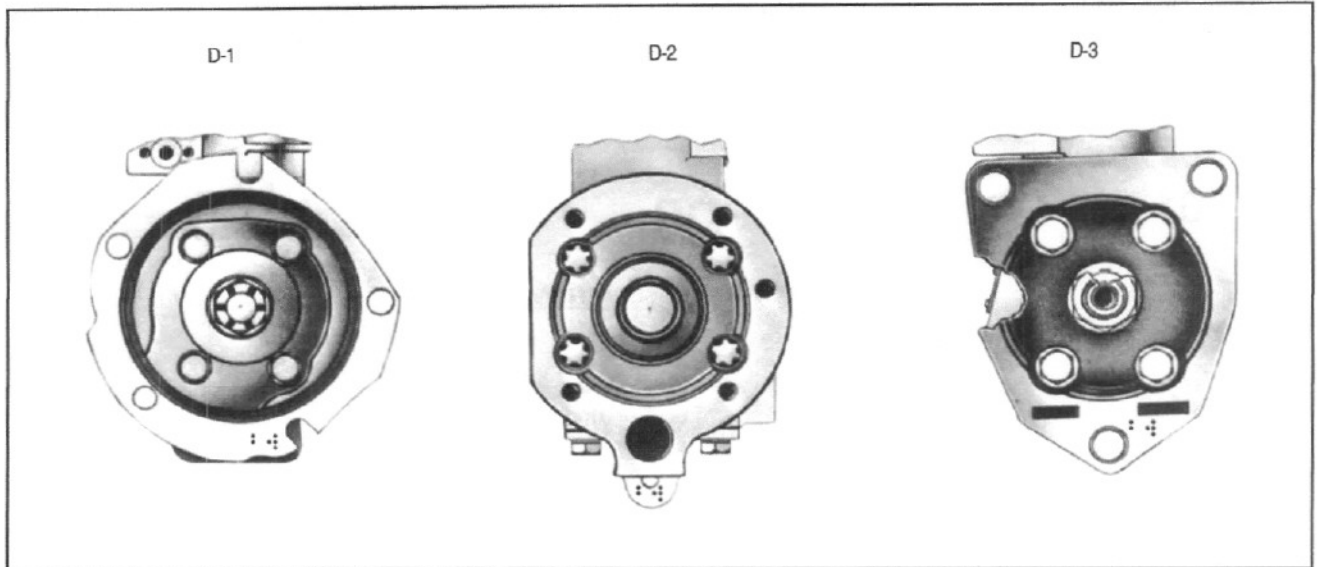

FIGURE 1 - VARIOUS COMPRESSOR MOUNTINGS

All Tu-Flo® 501 compressors utilize the engine's pressurized oil system to lubricate the internal moving parts.

A nameplate is attached to the crankcase to identify the compressor. The nameplate displays a Bendix piece number or in some cases an engine or vehicle manufacturer's piece number, along with a serial number.

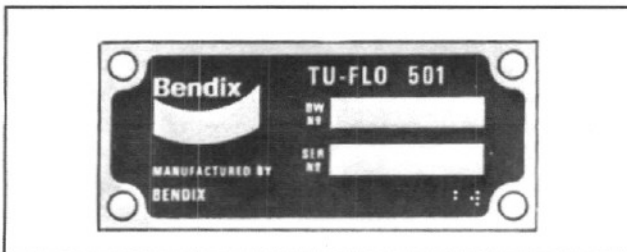

FIGURE 2 - COMPRESSOR NAMEPLATE

OPERATION

General

The compressor is driven by the vehicle engine and is operating continuously while the engine is running. Actual compression of air is controlled by the compressor unloading mechanism and the governor. The governor is generally mounted on the compressor and maintains the brake system air pressure to a preset maximum and minimum pressure level.

Intake and Compression of Air (Loaded)

During the down stroke of the piston, a slight vacuum is created between the top of the piston and the head, causing the flat circular inlet valve to move up and off its seat. (Note the flat square discharge valve remains on its seat.) Atmospheric air is drawn through the air strainer by the

open inlet valve and into the cylinder (see Fig. 4). As the piston begins its upward stroke, the air that was drawn into the cylinder on the down stroke is being compressed. Air pressure on top of the inlet valve plus the force of its spring, returns the inlet valve to its seat. The piston continues the upward stroke and compressed air then flows by the open discharge valve, into the discharge line and on to the reservoirs (see Fig. 5). As the piston reaches the top of its stroke and starts down, the discharge valve spring and air pressure in the discharge line returns the discharge valve to its seat. This prevents the compressed air in the discharge line from returning to the cylinder bore as the intake and compression cycle is repeated.

Non-Compression of Air (Unloaded)

When air pressure in the reservoir reaches the cut-out setting of the governor, the governor allows air to pass from the reservoir into the cavity beneath the unloader pistons. This lifts the unloader pistons and plungers. The plungers move up and hold the inlet valves off their seats (see Fig. 6).

With the inlet valves held off their seats by the unloader pistons and plungers, air is pumped back and forth between the two cylinders. When air is used from the reservoir and the pressure drops to the cut-in setting of the governor, the governor closes and exhausts the air from beneath the unloader pistons. The unloader saddle spring forces the saddle, pistons and plungers down and the inlet valves return to their seats. Compression is then resumed.

The Air Brake Charging System supplies the compressed air for the braking system as well as other air accessories for the vehicle. The system usually consists of an air compressor, governor, discharge line, air dryer, and service reservoir.

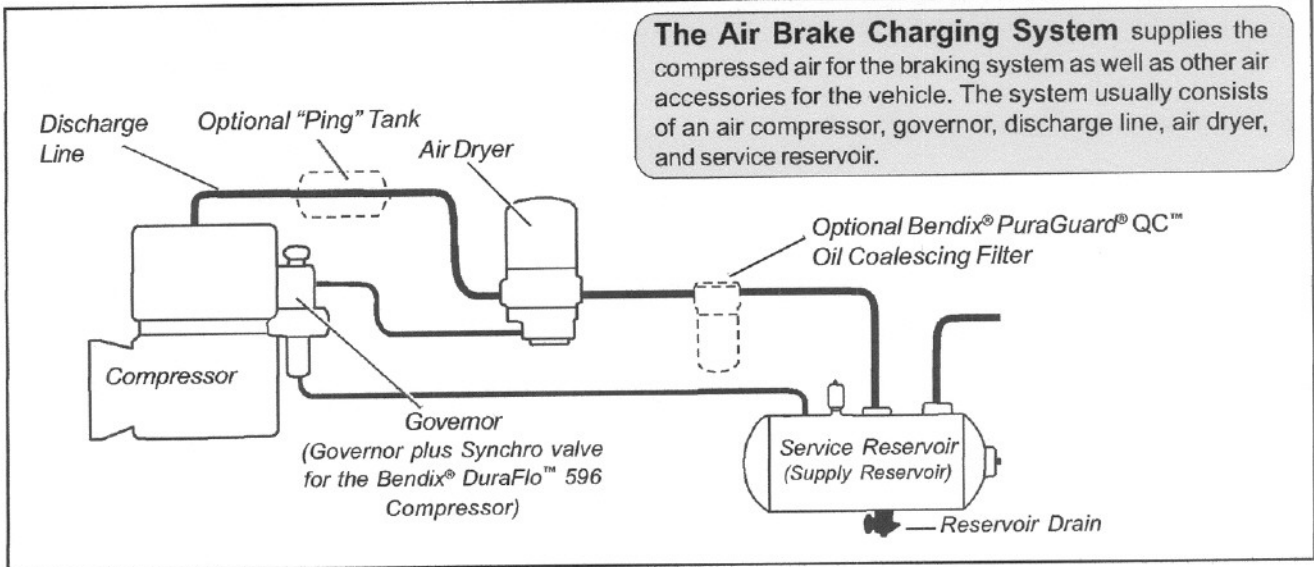

FIGURE 3A - SYSTEM DRAWING

COMPRESSOR & THE AIR BRAKE SYSTEM

GENERAL

The compressor is part of the total air brake system, more specifically, the charging portion of the air brake system. As a component in the overall system its condition, duty cycle, proper installation and operation will directly affect other components in the system.

Powered by the vehicle engine, the air compressor builds the air pressure for the air brake system. The air compressor is typically cooled by the engine coolant system, lubricated by the engine oil supply and has its inlet connected to the engine induction system.

As the atmospheric air is compressed, all the water vapor originally in the air is carried along into the air system, as well as a small amount of the lubricating oil as vapor. If an air dryer is not used to remove these contaminants prior to entering the air system, the majority, but not all, will condense in the reservoirs. The quantity of contaminants that reach the air system depends on several factors including installation, maintenance and contaminant handling devices in the system. These contaminants must either be eliminated prior to entering the air system or after they enter.

DUTY CYCLE

The duty cycle is the ratio of time the compressor spends building air to the total engine running time. Air compressors are designed to build air (run "loaded") up to 25% of the time. Higher duty cycles cause conditions that affect air brake charging system performance which may require additional maintenance. Factors that add to the duty cycle are: air suspension, additional air accessories, use of an undersized compressor, frequent stops, excessive leakage

from fittings, connections, lines, chambers or valves, etc. Refer to Table A in the Troubleshooting section for a guide to various duty cycles and the consideration that must be given to maintenance of other components.

COMPRESSOR INSTALLATION

While the original compressor installation is usually completed by the vehicle manufacturer, conditions of operation and maintenance may require additional consideration. The following presents base guidelines.

DISCHARGE LINE

The discharge line allows the air, water-vapor and oil-vapor mixture to cool between the compressor and air dryer or reservoir. The typical size of a vehicle's discharge line, (see column 2 of Table A in the Troubleshooting section) assumes a compressor with a normal (less than 25%) duty cycle, operating in a temperate climate. See Bendix and/or other air dryer manufacturer guidelines as needed.

The discharge line must maintain a constant slope down from the compressor to the air dryer inlet fitting or reservoir to avoid low points where ice may form and block the flow. If, instead, ice blockages occur at the air dryer or reservoir inlet, insulation may be added here, or if the inlet fitting is a typical 90 degree fitting, it may be changed to a straight or 45 degree fitting. Shorter discharge line lengths or insulation may be required in cold climates.

While not all compressors and charging systems are equipped with a discharge line safety valve this component is recommended. The discharge line safety valve is installed in the cylinder head (Tu-Flo® 550/750) or close to the compressor discharge port and protects against over pressurizing the compressor in the event of a discharge line freezeup.

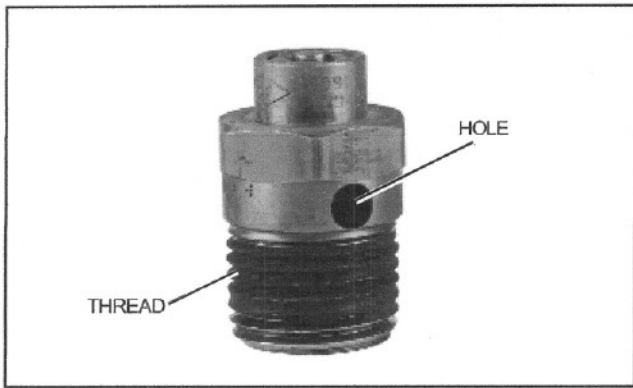

FIGURE 3B - DISCHARGE LINE SAFETY VALVE

DISCHARGE LINE TEMPERATURE

When the temperature of the compressed air that enters the air dryer is within the normal range, the air dryer can remove most of the charging system oil. If the temperature of the compressed air is above the normal range, oil as oil-vapor is able to pass through the air dryer and into the air system. Larger diameter discharge lines and/or longer discharge line lengths can help reduce the temperature.

The air dryer contains a filter that collects oil droplets, and a desiccant bed that removes almost all of the remaining water vapor. The compressed air is then passed to the air brake service (supply) reservoir. The oil droplets and the water collected are automatically purged when the governor reaches its "cut-out" setting.

For vehicles with accessories that are sensitive to small amounts of oil, we recommend installation of a Bendix® PuraGuard® QC™ oil coalescing filter, designed to minimize the amount of oil present.

Lubrication

Since all Tu-Flo® 501 compressors are connected to the engine's pressurized oil system, a continuous flow of oil is provided to the compressor, which is eventually returned to the engine.

Oil is fed into the compressor in various ways, for example: through the rear end cover, the drive end of the crankshaft or through the front flange adapter. An oil passage in the crankshaft conducts pressurized oil to the precision sleeve main bearings and to the connecting rod bearings. Splash lubrication of the cylinder bores, connecting rod wrist pin bushings, and the ball type main bearings, on some models, is obtained as oil is forced out around the crankshaft journals by engine oil pressure.

Check the exterior of the compressor for the presence of oil seepage and refer to the TROUBLESHOOTING section for appropriate tests and corrective action.

Cooling

Air flowing through the engine compartment from the action of the engine's fan and the movement of the vehicle assists in cooling the crankcase. Coolant flowing from the engine's cooling system through connecting lines enters the head and passes through the head's water jacket and back to the engine. Proper cooling is important in maintaining discharge air temperatures below the maximum 400°F recommended.

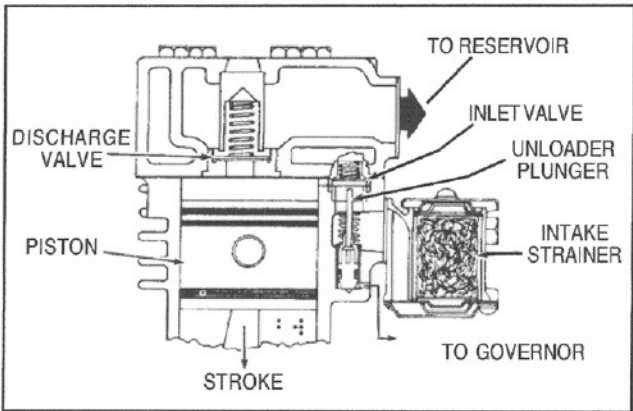

FIGURE 4 - INTAKE

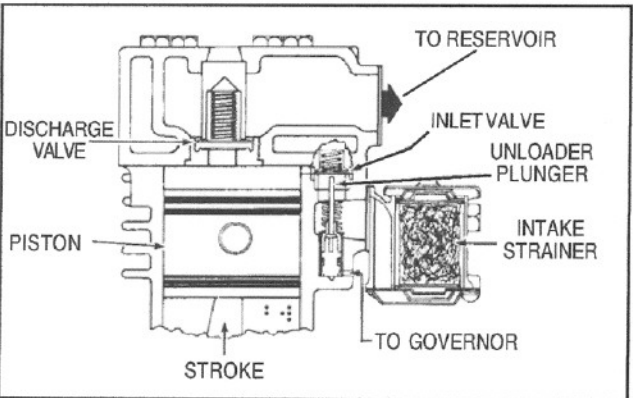

FIGURE 5 - COMPRESSION

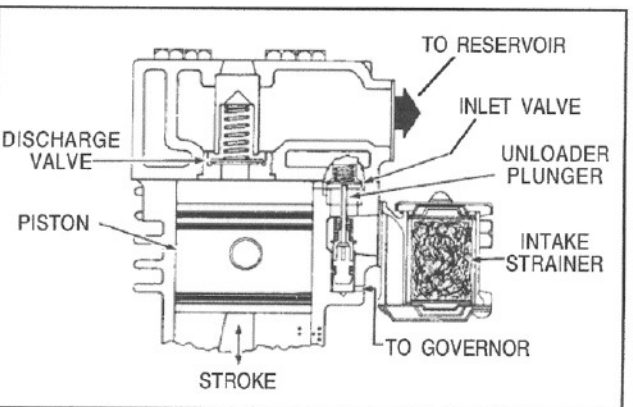

FIGURE 6 - UNLOADING

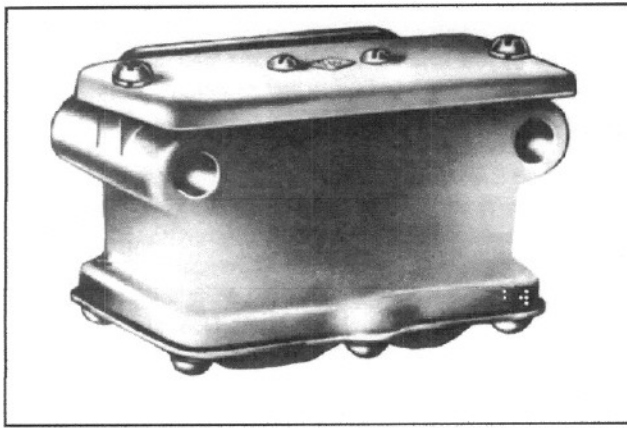

FIGURE 7 - POLYURETHANE SPONGE STRAINER

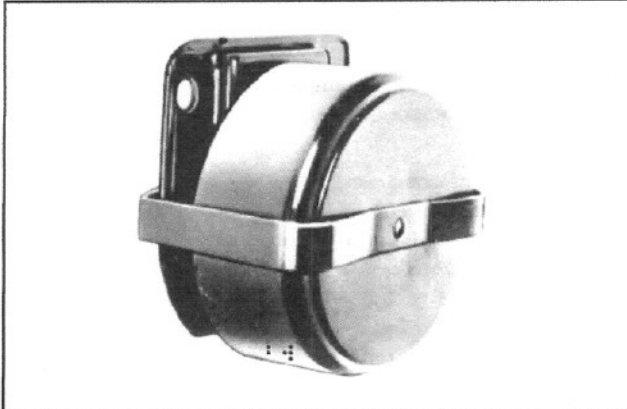

FIGURE 8 - PAPER AIR STRAINER DRY ELEMENT-PLEATED

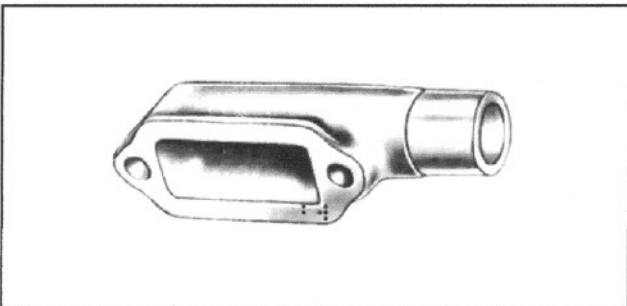

FIGURE 9 - COMPRESSOR INTAKE ADAPTER

PREVENTIVE MAINTENANCE

Regularly scheduled maintenance is the single most important factor in maintaining the air brake charging system. Refer to Table A in the Troubleshooting section for a guide to various considerations that must be given to the maintenance of the compressor and other related charging system components.

Every month, 300 operating hours or after each 10,000 miles, depending on the operating conditions, experience and the type of strainer used, service the air strainer.

POLYURETHANE SPONGE STRAINER EVERY 5000 MILES OR 150 OPERATING HOURS

Remove and wash all of the parts. The strainer element should be cleaned or replaced. If the element is cleaned, it should be washed in a commercial solvent or a detergent and water solution. The element should be saturated in clean engine oil, then squeezed dry before replacing it in the strainer. Be sure to replace the air strainer gasket if the entire air strainer is removed from the compressor intake.

DRY ELEMENT-PLEATED PAPER AIR STRAINER

EVERY 20,000 MILES OR 800 OPERATING HOURS

Remove the spring clips from either side of mounting baffle and remove the cover. Replace the pleated paper filter and remount the cleaned cover making sure the filter is in position. Be sure to replace the air strainer gasket if the entire air strainer is removed from the compressor intake.

(NOTE: Some compressors are fitted with compressor intake adapters which allow the compressor intake to be connected to the engine air cleaner.)

In this case, the compressor receives a supply of clean air from the engine air cleaner. When the engine air filter is changed, the compressor intake adapter should be checked. If it is loose, remove the intake adapter, clean the strainer plate, if applicable, and replace the intake adapter gasket, and reinstall the adapter securely. Check line connections both at the compressor intake adapter and at the engine air cleaner. Inspect the connecting line for ruptures and replace it if necessary.

EVERY 6 MONTHS, 1800 OPERATING HOURS OR AFTER EACH 50,000 MILES

Remove the discharge head fittings and inspect the compressor discharge port and discharge line for excessive carbon deposits. If excessive buildup is noted in either, the discharge line must be cleaned or replaced and the compressor checked more thoroughly, paying special attention to the air induction system, oil supply and return system, and proper cooling. If necessary, repair or replace the compressor. Check for proper belt and pulley alignment and belt tension. Adjust if necessary, paying special attention not to over tighten the belt tension. Check for noisy compressor operation, which could indicate a worn drive gear coupling or a loose pulley. Adjust and/or replace as necessary. Check all compressor mounting bolts and retighten evenly if necessary. Check for leakage and proper unloader mechanism operation. Replace if defective in any way.

EVERY 24 MONTHS, 7200 OPERATING HOURS OR AFTER EACH 200,000 MILES

Perform a thorough inspection as indicated below and depending upon the results of this inspection or experience, disassemble the compressor, clean and inspect all parts thoroughly, repair or replace all worn or damaged parts using only genuine Bendix replacements or replace the compressor with a genuine Bendix remanufactured unit.

IMPORTANT - Should it be necessary to drain the engine cooling system to prevent damage from freezing, the cylinder head of the compressor must also be drained.

GENERAL SERVICE CHECKS

Inspection

It is of the utmost importance that the compressor receives a clean supply of air. The air strainer must be properly installed and kept clean. If the compressor intake is connected to the engine air cleaner, supercharger, etc., these connections must be properly installed and maintained. Check the compressor mountings to be sure they are secure. Check the drive for proper alignment, belt tension, etc.

Inspect the oil supply and return lines. Be sure these lines are properly installed and that the compressor is getting the proper supply of oil, and just as important, that the oil is returning to the engine. Check the coolant lines to and from the compressor and see that the cooling fins on the crankcase are not clogged with dirt, grease, etc. Check the unloader mechanism for proper and prompt operation.

Operating Tests

Vehicles manufactured after the effective date of FMVSS 121, with the minimum required reservoir volume, must have a compressor capable of raising air system pressure from 85-100 P.S.I. in 25 seconds or less. This test is performed with the engine operating at maximum governed speed. The vehicle manufacturer must certify this performance on new vehicles with appropriate allowances for air systems with greater than the minimum required reservoir volume.

Air Leakage Tests

Leakage past the discharge valves can be detected by removing the discharge line, applying shop air back through the discharge port and listening for escaping air. Also, the discharge valves and the unloader pistons can be checked for leakage by building up the air system until the governor cuts out, then stopping the engine. With the engine stopped, listen for escaping air at the compressor intake. To pinpoint leakage if noted, apply a small quantity of oil around the unloader pistons. If there is no noticeable leakage at the unloader pistons, the discharge valves may be leaking. If the compressor does not function as described above, or leakage is excessive, it is recommended that it be returned

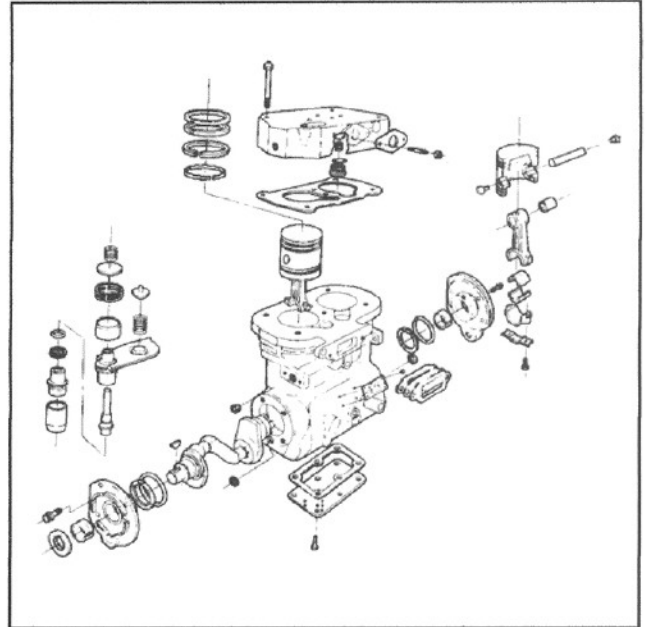

FIGURE 10 - TU-FLO® 501 AIR COMPRESSOR (THRU DRIVE) EXPLODED VIEW

to the nearest authorized Bendix Distributor for a factory remanufactured compressor. If this is not possible, the compressor can be repaired using genuine Bendix replacement parts, in which case, the following information should prove helpful.

REMOVING AND DISASSEMBLY

Removing

These instructions are general and are intended to be a guide, in some cases additional preparations and precautions are necessary. Chock the wheels of the vehicle and drain the air pressure from all the reservoirs in the system. Drain the engine cooling system and the cylinder head of the compressor. Disconnect all air, water and oil lines leading to and from the compressor. Remove the drive gear(s) or pulley from the compressor crankshaft using a gear puller. Inspect the pulley or gear and associated parts for visible wear or damage. Since these parts are precision fitted, they must be replaced if they are worn or damaged.

DISASSEMBLY

General

Remove road dirt and grease from the exterior of the compressor with a cleaning solvent. Before the compressor is disassembled, the following items should be marked to show their relationship when the compressor is assembled. Mark both the front and rear end cover in relation to the crankcase. Mark the drive end of the crankshaft in relation to the front end cover and the crankcase. Mark the cylinder head in relation to the crankcase. Mark the base plate or base adapter in relation to the crankcase.

A convenient method to indicate the above relationship is to use a metal scribe to mark the parts with numbers or lines. Do not use a marking method that can be wiped off or obliterated during rebuilding, such as chalk. Remove all compressor attachments such as governors, air strainers or inlet fittings, discharge fittings and pipe plugs.

Cylinder Head

Remove the six cylinder head cap screws and tap the head with a soft mallet to break the gasket seal. Remove the inlet valve springs from the head and inlet valves from their guides in the crankcase. Remove inlet valve guides from around the inlet valve seats on the crankcase taking care not to damage seats. Scrape off any gasket material from the cylinder head and crankcase. Unscrew the discharge valve seats from the head and remove the discharge valves and springs. Inspect the discharge valve seats for nicks, cracks, and excessive wear and replace if necessary.

The discharge valve stops should be inspected for wear and replaced if excessive peening has occurred. To determine if excessive peening has occurred, measure the discharge valve travel. Discharge valve travel must not exceed .057 inches. To remove the discharge valve stops, support the machined surface of the cylinder head on an arbor press bed and gently press the stops from the top of the head and out the bottom. Be sure to allow sufficient clearance for the stops between the press bed and the bottom of the cylinder head. The valve stop bores in the cylinder head must be inspected for excessive scoring. A new head body must be used if scoring is excessive. Discard the inlet valves and springs, the discharge valves and springs and the discharge valve seats if defective.

Crankcase Base Plate or Adapter

Remove the cap screws securing the base plate or base adapter. Tap with soft mallet to break the gasket seal. Scrape off any gasket material from crankcase and plate or adapter.

Connecting Rod Assemblies

(Note: Before removing the connecting rods, mark each connecting rod and its cap. Each connecting rod is matched to its own cap for proper bearing fit, and these parts must not be interchanged.)

Straighten the prongs of the connecting rod bolt lock strap and remove the bolts and bearing caps. Push the piston with the connecting rods attached out the top of the cylinders of the crankcase. Replace the bearing caps on their respective connecting rods. Remove the piston rings from the pistons. If the pistons are to be removed from the connecting rods, remove the wrist pin lock wires or teflon plugs and press the wrist pins from the pistons and connecting rods.

If the pistons are removed from the rod, inspect the bronze wrist pin bushing. Press out and replace the bushing if it is excessively worn. (See inspection of Parts) Discard the piston rings and the connecting rod journal bearings. Discard the wrist pin bushings if they were removed.

Crankcase

Remove the key or keys from the crankshaft and any burrs from the crankshaft where the key or keys were removed.

(Note: Through Drive Compressors may have a crankshaft key at both ends.)

Remove the four cap screws securing front or drive-end end cover or flange adapter. Remove the end cover, taking care not to damage the crankshaft oil seal or front main bearing, if any. Remove both of the small seal rings from the crankcase, and the o-ring from around the front end cover. Remove the four cap screws securing the rear end cover and remove the rear end cover taking care not to damage the rear main bearing, if any. Remove both of the small seal rings from the crankcase and the o-ring from around the end cover. If the compressor has ball type main bearings, press the crankshaft and ball bearings from the crankcase, then press the ball bearings from the crankshaft. Remove the unloader spring, spring saddle, and spring seat from the inlet cavity of the crankcase, using long nose pliers. Remove the unloader plungers and guides. Cover the inlet cavity with a shop rag and apply air pressure to the governor mounting pad unloader port to blow the unloader pistons out of their bores and into the inlet cavity.

CLEANING OF PARTS

General

All parts should be cleaned in a good commercial grade solvent and dried prior to inspection.

Cylinder Head

Remove all the carbon deposits from the discharge cavities and all the rust and scale from the cooling cavities of the cylinder head body. Scrape all the foreign matter from the body surfaces and use shop air pressure to blow the dirt particles from all the cavities.

Crankcase

Clean the carbon and dirt from the inlet and unloader passages. Use shop air pressure to blow the carbon and dirt deposits from the unloader passages.

Oil Passages

Thoroughly clean all oil passages through the crankshaft, crankcase, end covers, and base plate or base adapter. Inspect the passages with a wire to be sure. Blow the loosened foreign matter out with air pressure.

OIL PASSING

All reciprocating compressors currently manufactured will pass a minimal amount of oil. Air dryers will remove the majority of oil prior to entrance into the air brake system. For particularly oil sensitive systems the Bendix® PuraGuard® QC™ oil coalescing filter can be used in conjunction with a Bendix air dryer.

If compressor oil passing is suspected, refer to the TROUBLESHOOTING section and TABLE A for the symptoms and corrective action to be taken. In addition, Bendix has developed the "Bendix Air System Inspection Cup" or BASIC test to help substantiate suspected excessive oil passing. The steps to be followed when using the BASIC test are presented in APPENDIX A at the end of the TROUBLESHOOTING section.

INSPECTION OF PARTS

Cylinder Head Body

Inspect the cylinder head for cracks or damage. Apply shop air pressure to one of the coolant ports with all others plugged, and check for leakage by applying a soap solution to the exterior of the body. If leakage is detected, replace the head.

End Covers

Check for cracks and external damage. If the crankshaft main bearings are installed in the end cover, check for excessive wear and flat spots and replace them if necessary. If the compressor has an oil seal in the end cover, it should be removed by pressing it out of the end cover.

Crankcase

Check all crankcase surfaces for cracks and damage. On compressors where ball bearing main bearings are used the difference between the O.D. of the outer race and the I.D. of the crankcase hole should be .0000 in. to .0015 in. loose. This is to maintain the correct press fit. The crankcase must be replaced if the fit is too loose.

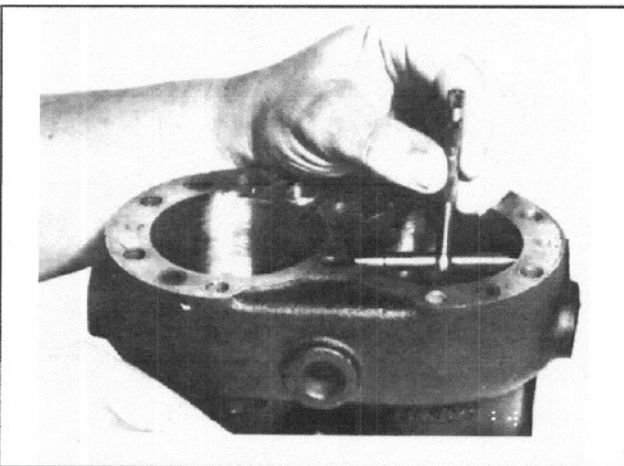

FIGURE 11 - MEASURING CYLINDER BORES

On compressors fitted with precision, sleeve main bearings, the difference between the O.D. of the crankshaft journal and the main bearing I.D. must not exceed .0065 in. If the clearance is greater than .0065 in., the end cover or main bearing must be replaced.

Check the unloader bore bushings to be sure they are not worn, rusted, or damaged. If these bushings are to be replaced, they can be removed by running a 1/8 in. pipe thread tap into the bushing, and inserting a 1/8 in. pipe threaded rod and pulling the bushing straight up and out. Do not use an easy-out for removing these bushings. If the inlet valve seats are worn or damaged, so they cannot be reclaimed by facing, they should be replaced. Cylinder bores should be checked with inside micrometers or calipers. (Fig. 11). Cylinder bores which are scored or out of round by more than .001 in. or tapered more than .002 in. should be rebored or honed oversize. Oversized pistons and piston rings are available in .010 in., .020 in. and .030 in. oversizes. Cylinder bores must be smooth, straight, and round. Clearance between the cast iron pistons and cylinder bores should be between .002 in. minimum and .004 in. maximum.

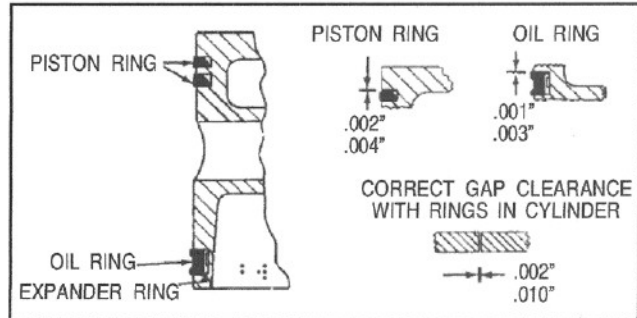

FIGURE 12 - CORRECT GROOVE CLEARANCE

Pistons

Check the pistons for scores, cracks, or enlarged ring grooves; replace the pistons if any of these conditions are found. Measure each piston with a micrometer in relation to the cylinder bore diameter to be sure the diametral clearance is between .002 in. minimum and .004 in. maximum.

Check the fit of the wrist pins to the pistons and connecting rod bushings. The wrist pin should be a light press fit in the piston. If the wrist pin is a loose fit, the piston and pin assembly should be replaced. Check the fit of the wrist pin in the connecting rod bushing by rocking the piston. This clearance should not exceed .0007 in. Replace the wrist pin bushings if excessive clearance is found. Wrist pin bushings should be reamed to between .5314 in. and .5317 in. after being pressed into the connecting rods.

Check the fit of the piston rings in the piston ring grooves. Check the ring gap with the rings installed in the cylinder bores. Refer to Fig. 12 for correct gap and groove clearances.

Crankshaft

Check the crankshaft threads, keyways, tapered ends and all machined and ground surfaces for wear, scores, or damage. Standard crankshaft journals are 1.1250 in. to 1.1242 in. in diameter. If the crankshaft journals are excessively scored or worn or out of round and cannot be reground, the crankshaft must be replaced. Connecting rod bearing inserts are available in .010 in., .020 in. and .030 in. undersizes for compressors with reground crankshafts. Main bearing journals must be maintained so the ball bearings are a snug fit or so that no more than .0065 in. clearance exists between the precision sleeve main bearing and the main bearing journals on the crankshaft. In crankshafts fitted with oil seal rings, the oil seal ring groove or grooves must not be worn. The ring groove walls must have a good finish and they must be square. Check to be sure the oil passages are open through the crankshaft.

Connecting Rod Bearings

Used bearing inserts must be replaced. Connecting rod caps are not interchangeable. The locking slots of the connecting rod and cap should be positioned adjacent to each other. Clearance between the connecting journal and the connecting rod bearing must not be less than .0003 in. or more than .0021 in. after rebuilding.

REPAIRS

Discharge Valves, Valve Stops and Seats

If the discharge valve seats merely show signs of slight wear, they can be dressed by using a lapping stone, grinding compound and grinding tool. If the discharge valve stops are to be replaced, an application of a sealer is required, such as "Locktite Retaining Compound #75." Be sure that the press fit between the discharge valve stop outside diameter and the valve stop bore in the cylinder head is a minimum of .0008 in. and a maximum of .0028 in. If this fit can not be maintained, a new cylinder head body must be used. Be sure to completely support the outside top of the cylinder head casting, while pressing in the replacement stops. Install the new discharge valve springs and valves. Screw in the discharge valve seats. Discharge valve travel should be between .041 in. to .057 in.

To test for leakage by the discharge valves, apply 100 pounds of air pressure through the cylinder head discharge port and apply a soap solution to the discharge valves and seats. A slight leakage in the form of soap bubbles is permissible. If excessive leakage is found, leave the air pressure applied and with the use of a fibre or hardwood dowel and a hammer, tap the discharge valves off their seats several times. This will help the valves to seat and should reduce the leakage. With the air pressure still applied at the discharge port of the cylinder head, check for leakage around the discharge valve stops exposed on the top of the cylinder head casting. No leakage is permitted.

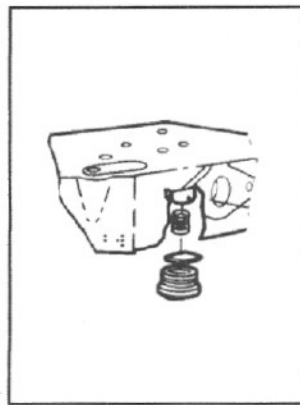

FIGURE 13 - DISCHARGE VALVE, VALVE STOP AND SEAT

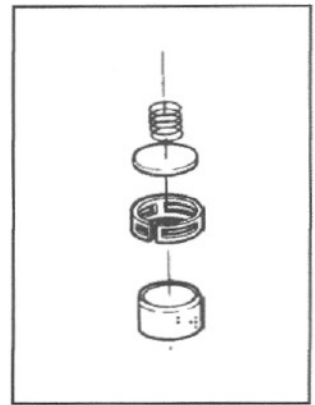

FIGURE 14 - INLET VALVE AND SEAT

Inlet Valves and Seats

Inlet valves and springs should be replaced, if the inlet valve seats show signs of slight nicks or scratches. They can be redressed with a fine piece of emery cloth or by lapping with a lapping stone, grinding compound and grinding tool. If the seats are damaged to the extent that they cannot be reclaimed, they must be replaced. The dimension from the top of the cylinder block to the inlet valve seat should not exceed .113 in. nor be less than .101 in.

ASSEMBLY

General Note: All torques specified in this manual are **assembly** torques and can be expected to fall off after assembly is accomplished. **Do not retorque** after initial assembly torques fall.

To convert inch pounds of torque to foot pounds of torque, divide inch pounds by 12.

$$\text{inch pounds} \div 12 = \text{foot pounds}$$

To convert foot pounds of torque to inch pounds of torque, multiply foot pounds by 12.

$$\text{foot pounds} \times 12 = \text{inch pounds}$$

Installing the Crankshaft

Cautionary Note:

All flange mounted compressors must be assembled without a gasket between the crankcase and flange adapter and some compressors do not require gaskets on the end cover. Install the new crankcase gaskets only where they were removed during disassembly. In service failure of the compressor will occur if gaskets are used in disregard of the preceding.

If the compressor uses a ball type main bearing, press the ball bearing onto the correct end of the crankshaft. Position the ball bearing and the crankshaft in the crankcase, making sure the drive end of the crankshaft is positioned in the crankcase as marked before disassembly. Carefully press the crankshaft and ball bearing into the crankcase using an arbor press.

In the case of compressors with a front ball bearing, place two small seal rings in the counter-sunk holes at the front of the crankcase, as well as an end cover gasket. Install the front end cover in the proper position as marked before disassembly, taking care not to damage the new oil seal.

In the case of compressors with a rear ball bearing, place two small seal rings in the counter-bore at the rear of the crankcase. In one case a gasket is used and in another a large o-ring is placed in the counterbore at the rear of the crankcase. These are in addition to the seal rings. Install the rear end cover in the proper position as marked before disassembly. Since June, 1978, the two small seal rings have been increased slightly in cross section and a retaining ring added, as shown in Figure 15.

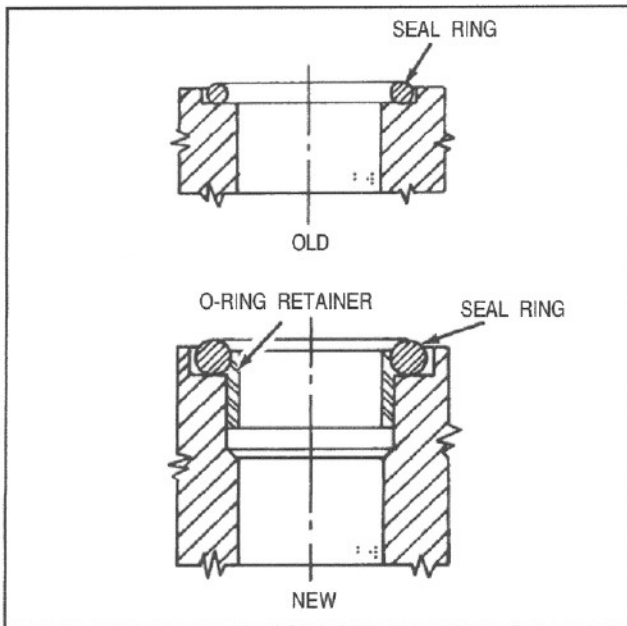

FIGURE 15

In the case of compressors with a sleeve bearing either front or rear, place the two small seal rings in the counter-sunk holes in the crankcase. **Caution:** An end cover gasket must not be used. Place the o-ring seal in the groove around the flange adapter or the end cover, and affix the thrust washer. Install the flange adapter or end cover in the proper position as marked before disassembly, taking care not to damage the sleeve bearing.

Secure the flange adapter, front or rear end cover to the crankcase by tightening the four cap screws. See note below for torque.

Note: For cast iron flange adapters, torque the four 7/16 in. cap screws to 38-45 foot pounds. For die cast aluminum end covers, torque the four 7/16 in. cap screws to 25-30 foot pounds. All end covers using 5/16 in. cap screws or stud and nuts are torqued to 15-18 foot pounds. For through drive compressors with a cast iron end cover, torque the four 7/16 in. cap screws to 25-30 foot pounds.

Pistons and Connecting Rods

If new wrist pin bushings are to be used, they should be pressed into the connecting rods so that the oil hole in the bushing lines up with the one in the rod. The new bushings should then be reamed or honed to provide between .0001 in. (.00254 mm) and .0006 in. (.01524 mm) clearance on the wrist pin. Position the connecting rod in the piston and press in the wrist pin.

Pistons installed in compressors manufactured prior to November, 1976, will have the wrist pin secured in the piston by a lock wire extending through matching holes in wrist pin and piston boss, anchored in a hole in the side wall of the piston. If the original pistons are used the wrist pin must be pressed in so the hole in the wrist pin aligns with that of the piston and secure same by inserting the new lockwire through the hole in piston and wrist pin and lock the wire by snapping the short 90° section into the lockwire hole in the bottom of the piston.

Compressors built after November, 1976, will have the wrist pin secured by Teflon buttons in either end of the wrist pin, allowing the wrist pin to float. The Teflon buttons pc. no. 292392 may be used with either new or old wrist pins. The later design pistons have two rings above the wrist pin and one below. Install the piston rings in the correct location with the ring pipemarks up. Stagger the position of the ring gaps. Pre-lubricate the piston, piston rings, wrist pins and connecting rod.

Unloader

A new unloader kit should be used when rebuilding. (Figure 14). (Piece Number 279615). The unloader pistons in the kit are pre-lubricated with a special lubricant piece number 239379 and need no additional lubrication. Install the unloader pistons in their bores being careful not to cut the o-rings. Position the unloader plungers in their guides and slip them in and over the tops of the pistons. Install the unloader spring seat in the crankcase inlet cavity; a small hole is drilled in the crankcase for this purpose. Position the saddle between the unloader piston guides, so its forks are centered on the guides. Install the unloader spring, making sure it seats over the spring seats both in the crankcase and on the saddle.

Position and install the inlet valve guides, then drop the inlet valves in their guides. The inlet valves should be a loose sliding fit in the guides.

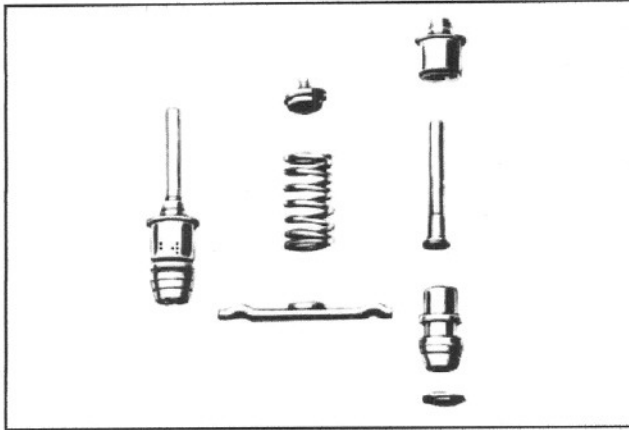

FIGURE 16 - UNLOADER MECHANISM

Cylinder Head

Install the inlet valve springs in the cylinder head by applying a turning motion to the spring after it is in the head. The turning motion should dig the spring wire into the spring seat in the bottom of the spring bore in the head. Should this procedure fail after repeated attempts, use a very small quantity of grease to hold them in place, just enough to keep the springs from falling out. Place the cylinder head gasket on the cylinder block. Carefully align the cylinder head assembly on the block and install the cap screws, tightening them evenly to a torque of 25-30 foot pounds.

Base Plate or Base Adapter

Position the base plate or base adapter gasket on the crankcase and install the base plate or base adapter as marked before disassembly. Tighten the six cap screws securing the cast iron base adapter evenly to a torque of 38-45 foot pounds, and 12-16 foot pounds for base plate or aluminum cover.

Testing Rebuilt Compressor

In order to properly test a compressor under operating conditions, a test rack for correct mounting, cooling, lubricating, and driving the compressor is necessary. Such tests are not compulsory if the unit has been carefully rebuilt by an experienced person. A compressor efficiency or build-up test can be run which is not too difficult. An engine lubricated compressor must be connected to an oil supply line of at least 15 P.S.I. pressure during the test and an oil return line must be installed to keep the crankcase drained.

Connect to the compressor discharge port, a reservoir with a volume of 1500 cubic inches, including the volume of connecting line. With the compressor operating at 2100 R.P.M., the time required to raise the reservoir(s) pressure from 85 P.S.I. to 100 P.S.I. should not exceed 7 seconds.

During this test, the compressor should be checked for gasket leakage and noisy operation, as well as unloader operation and leakage.

INSPECTION OF REBUILT UNIT

Check to be sure that covers, plugs, or masking tape are used to protect all ports if compressor is not to be installed immediately. Fit the end of all crankshafts with keys, nuts, and cotter pins as required and then protect the ends against damage by wrapping with masking tape or friction tape. The open bottom of a vertical engine lubricated compressors should be protected against the entrance of dirt during handling or storage, by installing a temporary cover over the base.

COMPRESSOR TROUBLESHOOTING

IMPORTANT: The troubleshooting contained in this section considers the compressor as an integrated component of the overall air brake charging system and assumes that an air dryer is in use. The troubleshooting presented will cover not only the compressor itself, but also other charging system devices as they relate to the compressor.

WARNING! PLEASE READ AND FOLLOW THESE INSTRUCTIONS TO AVOID PERSONAL INJURY OR DEATH:

When working on or around a vehicle, the following general precautions should be observed at all times.

1. Park the vehicle on a level surface, apply the parking brakes, and always block the wheels. Always wear safety glasses.
2. Stop the engine and remove ignition key when working under or around the vehicle. When working in the engine compartment, the engine should be shut off and the ignition key should be removed. Where circumstances require that the engine be in operation, **EXTREME CAUTION** should be used to prevent personal injury resulting from contact with moving, rotating, leaking, heated or electrically charged components.
3. Do not attempt to install, remove, disassemble or assemble a component until you have read and thoroughly understand the recommended procedures. Use only the proper tools and observe all precautions pertaining to use of those tools.
4. If the work is being performed on the vehicle's air brake system, or any auxiliary pressurized air systems, make certain to drain the air pressure from all reservoirs before beginning **ANY** work on the vehicle. If the vehicle is equipped with an AD-IS™ air dryer system or a dryer reservoir module, be sure to drain the purge reservoir.
5. Following the vehicle manufacturer's recommended procedures, deactivate the electrical system in a manner that safely removes all electrical power from the vehicle.

6. Never exceed manufacturer's recommended pressures.
7. Never connect or disconnect a hose or line containing pressure; it may whip. Never remove a component or plug unless you are certain all system pressure has been depleted.
8. Use only genuine Bendix® replacement parts, components and kits. Replacement hardware, tubing, hose, fittings, etc. must be of equivalent size, type and strength as original equipment and be designed specifically for such applications and systems.
9. Components with stripped threads or damaged parts should be replaced rather than repaired. Do not attempt repairs requiring machining or welding unless specifically stated and approved by the vehicle and component manufacturer.
10. Prior to returning the vehicle to service, make certain all components and systems are restored to their proper operating condition.
11. For vehicles with Antilock Traction Control (ATC), the ATC function must be disabled (ATC indicator lamp should be ON) prior to performing any vehicle maintenance where one or more wheels on a drive axle are lifted off the ground and moving.

TABULATED DATA

Number of cylinders	2
Bore size	2.625 in.
Stroke	1.50 in.
Piston displacement at 1250 RPM	12 cu. ft.
Piston displacement per revolution	16.5 cu. in.
Maximum recommended RPM (naturally aspirated)	3000
Minimum coolant flow at maximum RPM	2.5 gal./min.
Horsepower required at 3000 RPM against 100 PSI head pressure	4.9 H.P.
Recommended minimum discharge line size	5/8 in. OD Copper Tube
Recommended minimum oil return line size	5/8 in. OD Tubing
Recommended minimum oil supply line size	1/4 in. OD Tubing
Recommended minimum unloader line size	1/4 in. OD Tubing
Recommended minimum inlet cavity line size (when compressor is connected to engine air cleaner)	5/8 in. ID minimum
Recommended minimum coolant line size	1/2 in. OD Tubing
Recommended maximum inlet air temperature	250°F
Recommended maximum discharge air temperature	400°F
Minimum pressure required to unload	60 PSI

Advanced Troubleshooting Guide for Air Brake Compressors*

The guide consists of an introduction to air brake charging system components, a table showing recommended vehicle maintenance schedules, and a troubleshooting symptom and remedy section with tests to diagnose most charging system problems.

INDEX

Symptom	Page Number	Symptom	Page Number
Air		Coolant	
Air brake charging system:		Compressor leaks coolant (17.0)	25
Slow build (9.0)	21 - 22	Engine	
Doesn't build air (10.0)	23	Oil consumption (6.0)	21
Air dryer:		Oil	
Doesn't purge (14.0)	24	Oil Test Card results (1.0)	16
Safety valve releases air (12.0)	24	Oil is present:	
Compressor:		On the outside of the compressor (2.0)	17
Constantly cycles (15.0)	24	At the air dryer purge/exhaust	
Leaks air (16.0)	25	or surrounding area (3.0)	17
Safety valve releases air (11.0)	23	In the supply reservoir (4.0)	18 - 20
Noisy (18.0)	25	At the valves (5.0)	20
Reservoir:		At air dryer cartridge (7.0)	21
Safety valve releases air (13.0)	24	In the ping tank or compressor	
		discharge aftercooler (8.0)	21

Test Procedures

- (1) Oil Leakage at Head Gasket . . . 26
- (2) System Leakage 26
- (3) Compressor Discharge and
 Air Dryer Inlet Temperature 26
- (4) Governor Malfunction 27
- (5) Governor Control Line 27
- (6) Compressor Unloader 27
- BASIC Test Information 29-31

Maintenance & Usage Guidelines

- Maintenance Schedule and
Usage Guidelines (Table A) . . 15



*This guide is only for vehicles that use desiccant air dryers.

Introduction to the Air Brake Charging System

Powered by the vehicle engine, the **air compressor** builds the air pressure for the air brake system. The air compressor is typically cooled by the engine coolant system and lubricated by the engine oil supply.

The compressor's unloader mechanism and **governor** (along with a synchro valve for the Bendix® DuraFlo™ 596 air compressor) control the brake system air pressure between a preset maximum and minimum pressure level by monitoring the pressure in the service (or "supply") reservoir. When the air pressure becomes greater than that of the preset "cut-out", the governor controls the unloader mechanism of the compressor to stop the compressor from building air and also causes the air dryer to purge. As the service reservoir air pressure drops to the "cut-in" setting of the governor, the governor returns the compressor back to building air and the air dryer to air drying mode.

As the atmospheric air is compressed, all the water vapor originally in the air is carried along into the air system, as well as a small amount of the lubricating oil as vapor.

The **duty cycle** is the ratio of time the compressor spends building air to the total engine running time. Air compressors are designed to build air (run "loaded") up to 25% of the time. Higher duty cycles cause conditions that affect air brake charging system performance which may require additional maintenance. Factors that add to the duty cycle are: air suspension, additional air accessories, use of an undersized compressor, frequent stops, excessive leakage from fittings, connections, lines, chambers or valves, etc.

The **discharge line** allows the air, water-vapor and oil-vapor mixture to cool between the compressor and

air dryer. The typical size of a vehicle's discharge line, (see column 2 of Table A on page 15) assumes a compressor with a normal (less than 25%) duty cycle, operating in a temperate climate. See Bendix and/or other air dryer manufacturer guidelines as needed.

When the **temperature** of the compressed air that enters the air dryer is within the normal range, the air dryer can remove most of the charging system oil. If the temperature of the compressed air is above the normal range, oil as oil-vapor is able to pass through the air dryer and into the air system. Larger diameter discharge lines and/or longer discharge line lengths can help reduce the temperature.

The discharge line must maintain a **constant slope** down from the compressor to the air dryer inlet fitting to avoid low points where ice may form and block the flow. If, instead, ice blockages occur at the air dryer inlet, insulation may be added here, or if the inlet fitting is a typical 90 degree fitting, it may be changed to a straight or 45 degree fitting. For more information on how to help prevent discharge line freeze-ups, see Bendix Bulletins TCH-08-21 and TCH-08-22 (see pages 32-34). Shorter discharge line lengths or insulation may be required in cold climates.

The **air dryer** contains a filter that collects oil droplets, and a desiccant bed that removes almost all of the remaining water vapor. The compressed air is then passed to the air brake service (supply) reservoir. The oil droplets and the water collected are automatically purged when the governor reaches its "cut-out" setting.

For vehicles with accessories that are sensitive to small amounts of oil, we recommended installation of a Bendix® PuraGuard® system filter, designed to minimize the amount of oil present.

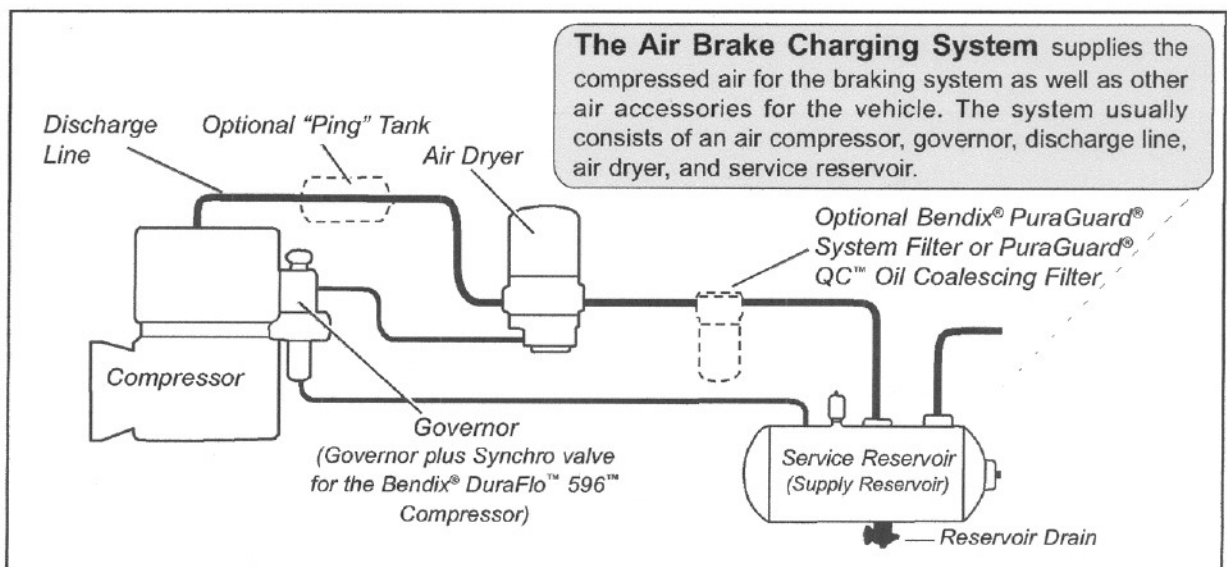

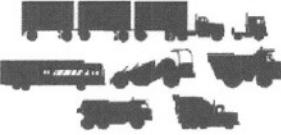



Table A: Maintenance Schedule and Usage Guidelines

Regularly scheduled maintenance is the single most important factor in maintaining the air brake charging system.

Vehicle Used for:	No. of Axles	Column 1	Column 2		Column 3	Column 4	Column 5
		Typical Compressors Spec'd	Discharge Line		Recommended Air Dryer Cartridge Replacement ¹	Recommended Reservoir Drain Schedule ²	Acceptable Reservoir Oil Contents ³ at Regular Drain Interval
			I.D.	Length			
Low Air Use							
Compressor with less than 15% duty cycle e.g. Line haul single trailer w/o air suspension, air over hydraulic brakes. 	5 or less	Bendix® Tu-Flo® 550 air compressor	1/2 in.	6 ft.	Every 3 Years	Recommended Every Month - Max of every 90 days	BASIC test acceptable range: 3 oil units per month. See appendix A.
Compressor with up to 25% duty cycle e.g. Line haul single trailer with air suspension, school bus. 	5 or less		1/2 in.	9 ft.			
High Air Use							
Compressor with up to 25% duty cycle e.g. Double/triple trailer, open highway coach/RV, (most) pick-up & delivery, yard or terminal jockey, off-highway, construction, loggers, concrete mixer, dump truck, fire truck. 	8 or less	Bendix® Tu-Flo® 750 air compressor	1/2 in.	12 ft.	Every 2 Years	Every Month	BASIC test acceptable range: 5 oil units per month. See appendix A.
Compressor with up to 25% duty cycle e.g. City transit bus, refuse, bulk unloaders, low boys, urban region coach, central tire inflation. 	12 or less		Bendix® BA-922 ⁵ or DuraFlo [®] 596 air compressor	5/8 in.			

Footnotes:

- 1 With increased air demand the air dryer cartridge needs to be replaced more often.
- 2 Use the drain valves to slowly drain all reservoirs to zero psi.
- 3 Allow the oil/water mixture to fully settle before measuring oil quantity.
- 4 To counter above normal temperatures at the air dryer inlet, (and resultant oil-vapor passing upstream in the air system) replace the discharge line with one of a larger diameter and/or longer length. This helps reduce the air's temperature. If sufficient cooling occurs, the oil-vapor condenses and can be removed by the air dryer. Discharge line upgrades are not covered under warranty. Note: To help prevent discharge line freeze-ups, shorter discharge line lengths or insulation may be required in cold climates. (See Bendix Bulletins TCH-08-21 and TCH-08-22, included in Appendix B, for more information.)
- 5 For certain vehicles/applications, where turbo-charged inlet air is used, a smaller size compressor may be permissible.

Note: Compressor and/or air dryer upgrades are recommended in cases where duty cycle is greater than the normal range (for the examples above).

For Bendix® Tu-Flo® 550 and 750 compressors, unloader service is recommended every 250,000 miles.

Air Brake Charging System Troubleshooting

How to use this guide:

Find the **symptom(s)** that you see, then move to the right to find the possible causes ("**What it may indicate**") and remedies ("**What you should do**").

Review the warranty policy before performing any intrusive compressor maintenance. Unloader or cylinder head gasket replacement and resealing of the bottom cover plate are usually permitted under warranty. Follow all standard safety procedures when performing any maintenance.

Look for:

 **Normal**

Normal - Charging system is working within normal range.

 **Check**

Check - Charging system needs further investigation.

WARNING! Please READ and follow these instructions to avoid personal injury or death:

When working on or around a vehicle, the following general precautions should be observed at all times.

1. Park the vehicle on a level surface, apply the parking brakes, and always block the wheels. Always wear safety glasses.
2. Stop the engine and remove ignition key when working under or around the vehicle. When working in the engine compartment, the engine should be shut off and the ignition key should be removed. Where circumstances require that the engine be in operation, **EXTREME CAUTION** should be used to prevent personal injury resulting from contact with moving, rotating, leaking, heated or electrically charged components.
3. Do not attempt to install, remove, disassemble or assemble a component until you have read and thoroughly understand the recommended procedures. Use only the proper tools and observe all precautions pertaining to use of those tools.
4. If the work is being performed on the vehicle's air brake system, or any auxiliary pressurized air systems, make certain to drain the air pressure from all reservoirs before beginning ANY work on the vehicle. If the vehicle is equipped with an AD-IS™ air dryer system or a dryer reservoir module, be sure to drain the purge reservoir.

5. Following the vehicle manufacturer's recommended procedures, deactivate the electrical system in a manner that safely removes all electrical power from the vehicle.
6. Never exceed manufacturer's recommended pressures.
7. Never connect or disconnect a hose or line containing pressure; it may whip. Never remove a component or plug unless you are certain all system pressure has been depleted.
8. Use only genuine Bendix® replacement parts, components and kits. Replacement hardware, tubing, hose, fittings, etc. must be of equivalent size, type and strength as original equipment and be designed specifically for such applications and systems.
9. Components with stripped threads or damaged parts should be replaced rather than repaired. Do not attempt repairs requiring machining or welding unless specifically stated and approved by the vehicle and component manufacturer.
10. Prior to returning the vehicle to service, make certain all components and systems are restored to their proper operating condition.
11. For vehicles with Antilock Traction Control (ATC), the ATC function must be disabled (ATC indicator lamp should be ON) prior to performing any vehicle maintenance where one or more wheels on a drive axle are lifted off the ground and moving.

Symptom:	What it may indicate:	What you should do:
----------	-----------------------	---------------------

1.0 Oil Test Card Results

Not a valid test.

Discontinue using this test.

Do not use this card test to diagnose compressor "oil passing" issues. They are subjective and error prone. Use only the Bendix Air System Inspection Cup (BASIC) test and the methods described in this guide for advanced troubleshooting.

The Bendix® BASIC test should be the definitive method for judging excessive oil fouling/oil passing. (See Appendix A, on page 29 for a flowchart and expanded explanation of the checklist used when conducting the BASIC test.)



Bendix® BASIC Test



Symptom:	What it may indicate:	What you should do:
----------	-----------------------	---------------------

2.0 Oil on the Outside of the Compressor

Engine and/or other accessories leaking onto compressor.

Find the source and repair. Return the vehicle to service.

2.1 Oil leaking at compressor / engine connections:

(a) Leak at the front or rear (fuel pump, etc.) mounting flange.

⇒ Repair or replace as necessary. If the mounting bolt torques are low, replace the gasket.

(b) Leak at air inlet fitting.

⇒ Replace the fitting gasket. Inspect inlet hose and replace as necessary.

(c) Leak at air discharge fitting.

⇒ Replace gasket or fitting as necessary to ensure good seal.

(d) Loose/broken oil line fittings.

⇒ Inspect and repair as necessary.

2.2 Oil leaking from compressor:

(a) Excessive leak at head gasket.

⇒ Go to Test 1 on page 26.

(b) Leak at bottom cover plate.

⇒ Reseal bottom cover plate using RTV silicone sealant.

(c) Leak at internal rear flange gasket.

⇒ Replace compressor.

(d) Leak through crankcase.

⇒ Replace compressor.

(e) (If unable to tell source of leak.)

⇒ Clean compressor and check periodically.

? Check

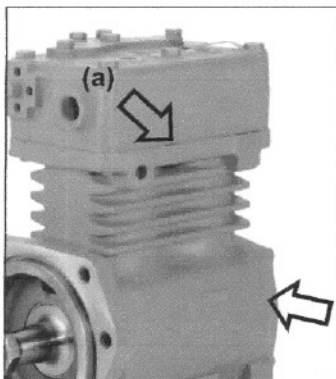

Head gasket and rear flange gasket locations.

3.0 Oil at air dryer purge/exhaust or surrounding area

Air brake charging system functioning normally.

✓ Normal

⇒ Air dryers remove water and oil from the air brake charging system.

Check that regular maintenance is being performed. Return the vehicle to service. An optional kit (Bendix piece number 5011327 for the Bendix® AD-IS™ or AD-IP™ air dryers, or 5003838 for the Bendix® AD-9™ air dryer) is available to redirect the air dryer exhaust.

Symptom:**What it may indicate:****What you should do:****4.0 Oil in Supply or Service Reservoir (air dryer installed)**

(If a maintained Bendix® PuraGuard® system filter or Bendix® PuraGuard® QC™ oil coalescing filter is installed, call 1-800-AIR-BRAKE (1-800-247-2725) and speak to a Tech Team member.)



See Table A, on page 15, for maintenance schedule information.

Maintenance

- (a) If air brake charging system maintenance **has not been performed**.

That is, reservoir(s) **have not** been drained per the schedule in Table A on page 15, Column 4 **and/or** the air dryer maintenance **has not** been performed as in Column 3.

- (b) If the vehicle maintenance **has been performed** as recommended in Table A on page 15, some oil in the reservoirs is normal.

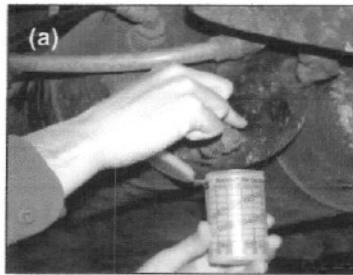

Drain all air tanks (reservoirs) into the Bendix® BASIC test cup. (Bendix kit P/N 5013711).

- ⇒ Drain all air tanks and check vehicle at next service interval using the Bendix® BASIC test. See Table A on page 15, column 3 and 4, for recommended service schedule.

? Check

- ⇒ Drain all air tanks into Bendix® BASIC test cup (Bendix Air System Inspection Cup). If less than one unit of reservoir contents is found, the vehicle can be returned to service. **Note: If more than one oil unit of water (or a cloudy emulsion mixture) is present, change the vehicle's air dryer, check for air system leakage (Test 2, on page 26), stop inspection and check again at the next service interval. See the BASIC test kit for full details.**

If less than one "oil unit" of water (or water/cloudy emulsion mixture) is present, use the BASIC cup chart on the label of the cup to determine if the amount of oil found is within the acceptable level.

⇒ If within the normal range, return the vehicle to service. For vehicles with accessories that are sensitive to small amounts of oil, consider a Bendix® PuraGuard® QC™ oil coalescing filter.

⇒ If outside the normal range go to Symptom 4.0(c).

Also see the Table A on page 15, column 3 for recommended air dryer cartridge replacement schedule.

Duty cycle too high

- (c) Air brake system leakage.

- ⇒ Go to Test 2 on page 26.

- (d) Compressor may be undersized for the application.

- ⇒ See Table A, column 1, on page 15 for recommended compressor sizes.

⇒ If the compressor is "too small" for the vehicle's role (for example, where a vehicle's use has changed or service conditions exceed the original vehicle or engine OE spec's) then upgrade the compressor. Note: The costs incurred (e.g. installing a larger capacity compressor, etc.) are not covered under original compressor warranty.

⇒ If the compressor is correct for the vehicle, go to Symptom 4.0 (e).

The **duty cycle** is the ratio of time the compressor spends building air to total engine running time. Air compressors are designed to build air (to "run loaded") up to 25% of the time. Higher duty cycles cause conditions that affect air brake charging system performance which may require additional maintenance. Factors that add to the duty cycle are: air suspension, additional air accessories, use of an undersized compressor, frequent stops, excessive leakage from fittings, connections, lines, chambers or valves, etc.

Symptom:**What it may indicate:****What you should do:**

**4.0 Oil in Supply
or Service
Reservoir*
(air dryer installed)
(continued)**

Temperature

(e) Air compressor discharge and/or air dryer inlet temperature too high.

(f) Insufficient coolant flow.



Testing the temperature at the discharge fitting.

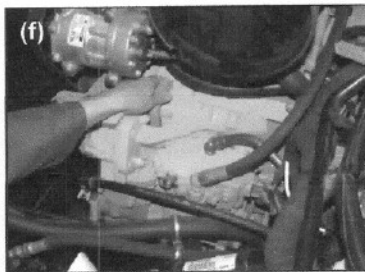

Inspecting the coolant hoses.

(g) Restricted discharge line.

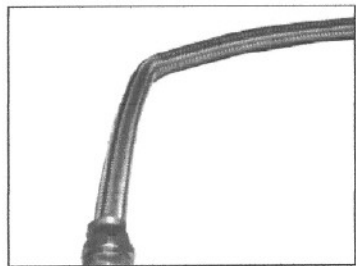

Kinked discharge line shown.

Other

(h) Restricted air inlet (not enough air to compressor).

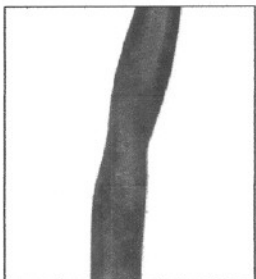

Partly collapsed inlet line shown.

⇒ Check temperature as outlined in Test 3 on page 26. If temperatures are normal go to 4.0(h).

⇒ Inspect coolant line. Replace as necessary (I.D. is 1/2").

⇒ Inspect the coolant lines for kinks and restrictions and fittings for restrictions. Replace as necessary.

⇒ Verify coolant lines go from engine block to compressor and back to the water pump. Repair as necessary.

⇒ If discharge line is restricted or more than 1/16" carbon build up is found, replace the discharge line. See Table A, column 2, on page 15 for recommended size. Replace as necessary.

⇒ The discharge line must maintain a **constant slope** down from the compressor to the air dryer inlet fitting to avoid low points where ice may form and block the flow. If, instead, ice blockages occur at the air dryer inlet, insulation may be added here, or if the inlet fitting is a typical 90 degree fitting, it may be changed to a straight or 45 degree fitting. For more information on how to help prevent discharge line freeze-ups, see Bendix Bulletins TCH-08-21 and TCH-08-22 (Appendix B). Shorter discharge line lengths or insulation may be required in cold climates.

⇒ Check compressor air inlet line for restrictions, brittleness, soft or sagging hose conditions etc. Repair as necessary. Inlet line size is 3/4 ID. Maximum restriction requirement for compressors is 25 inches of water.

⇒ Check the engine air filter and service if necessary (if possible, check the air filter usage indicator).

? Check

*If a maintained Bendix® PuraGuard® system filter or Bendix® PuraGuard® QC™ oil coalescing filter is installed, call 1-800-AIR-BRAKE (1-800-247-2725) and speak to a Tech Team member.

Symptom:	What it may indicate:	What you should do:
----------	-----------------------	---------------------

4.0 Oil in Supply or Service Reservoir* (air dryer installed) (continued)

Other (cont.)

(i) Poorly filtered inlet air (poor air quality to compressor).



Inspect the engine air cleaner.

(j) Governor malfunction or setting.
(k) Compressor malfunction.

⇒ Check for leaking, damaged or defective compressor air inlet components (e.g. induction line, fittings, gaskets, filter bodies, etc.). Repair inlet components as needed. Note: Dirt ingestion will damage compressor and is not covered under warranty.

? Check

⇒ Go to Test 4 on page 27.

⇒ If you found excessive oil present in the service reservoir in step 4.0 (b) above and you did not find any issues in steps 4.0 (c) through 4.0 (j) above, the compressor may be passing oil. Replace compressor. If still under warranty, follow normal warranty process. Note: After replacing a compressor, residual oil may take a considerable period of time to be flushed from the air brake system.

Crankcase Flooding
Consider installing a compressor bottom drain kit (where available) in cases of chronic oil passing where all other operating conditions have been investigated. Bendix compressors are designed to have a 'dry' sump and the presence of excess oil in the crankcase can lead to oil carryover.

*If a maintained Bendix® PuraGuard® system filter or Bendix® PuraGuard® QC™ oil coalescing filter is installed, call 1-800-AIR-BRAKE (1-800-247-2725) and speak to a Tech Team member.

5.0 Oil present at valves (e.g. at exhaust, or seen during servicing).

Air brake system valves are required to tolerate a light coating of oil.

✓ Normal



⇒ A small amount of oil does not affect SAE J2024** compliant valves.
⇒ Check that regular maintenance is being performed and that the amount of oil in the air tanks (reservoirs) is within the acceptable range shown on the Bendix® BASIC test cup (see also column 5 of Table A on page 15). Return the vehicle to service.

For oil-sensitive systems, see page 14.

** SAE J2024 outlines tests all air brake system pneumatic components need to be able to pass, including minimum levels of tolerance to contamination.



Genuine Bendix valves are all SAE J2024 compliant.

Symptom:	What it may indicate:	What you should do:
<p>6.0 Excessive oil consumption in engine.</p>	<p>A problem with engine or other engine accessory.</p>  <p>The engine service manual has more information.</p>	<p>⇒ See engine service manual.</p> <p>? Check</p>
<p>7.0 Oil present at air dryer cartridge during maintenance.</p>	<p>Air brake charging system is functioning normally.</p>  <p>Oil shown leaking from an air dryer cartridge.</p> <p>✓ Normal</p>	<p>⇒ Air dryers remove water and oil from the air brake charging system. A small amount of oil is normal. Check that regular maintenance is being performed and that the amount of oil in the air tanks (reservoirs) is within the acceptable range shown by the BASIC Test (see also column 5 of Table A on page 15). Replace the air dryer cartridge as needed and return the vehicle to service.</p>
<p>8.0 Oil in ping tank or compressor discharge aftercooler.</p>	<p>Air brake charging system is functioning normally.</p> <p>✓ Normal</p>	<p>⇒ Follow vehicle O.E. maintenance recommendation for these components.</p>
<p>9.0 Air brake charging system seems slow to build pressure.</p>	<p>(a) Air brake charging system functioning normally.</p> <p>✓ Normal</p>	<p>⇒ Using dash gauges, verify that the compressor builds air system pressure from 85-100 psi in 40 seconds or less with engine at full governed rpm. Return the vehicle to service.</p>
	<p>(b) Air brake system leakage.</p>	<p>⇒ Go to Test 2 on page 26.</p>
	<p>(c) Compressor may be undersized for the application.</p>	<p>⇒ See Table A, column 1, on page 15 for some typical compressor applications. If the compressor is "too small" for the vehicle's role, for example, where a vehicle's use has changed, then upgrade the compressor. Note: The costs incurred (e.g. installing a larger capacity compressor, etc.) are not covered under original compressor warranty.</p>
	<p>(d) Compressor unloader mechanism malfunction.</p>	<p>⇒ Go to Test 6 on page 27.</p>
	<p>(e) Damaged compressor head gasket.</p>	<p>⇒ An air leak at the head gasket may indicate a downstream restriction such as a freeze-up or carbon blockage and/or could indicate a defective or missing safety valve. Find blockage (go to 9.0(f) for details.) and then replace the compressor. Do not re-use the safety valve without testing. See Symptom 12.0(a).</p>

9.0 Air brake charging system seems slow to build pressure. (continued)

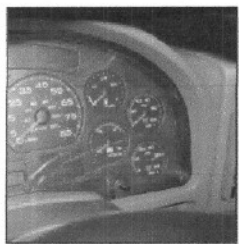

Dash gauges.

(f) Restricted discharge line.

? Check



Kinked discharge line shown.

- ⇒ If discharge line is restricted:
 - ⇒ By more than 1/16" carbon build up, replace the discharge line (see Table A, column 2, on page 15 for recommended size) and go to Test 3 on page 26.
 - ⇒ By other restrictions (e.g. kinks). Replace the discharge line. See Table A, column 2, on page 15 for recommended size. Retest for air build. Return vehicle to service or, if problem persists, go to 9.0(a).

- ⇒ The discharge line must maintain a **constant slope** down from the compressor to the air dryer inlet fitting to avoid low points where ice may form and block the flow. If, instead, ice blockages occur at the air dryer inlet, insulation may be added here, or if the inlet fitting is a typical 90 degree fitting, it may be changed to a straight or 45 degree fitting. For more information on how to help prevent discharge line freeze-ups, see Bendix Bulletins TCH-08-21 and TCH-08-22 (Appendix B). Shorter discharge line lengths or insulation may be required in cold climates.

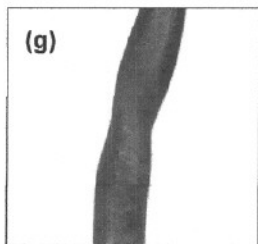

Partly collapsed inlet line shown.

(g) Restricted air inlet (not enough air to compressor).

? Check

- ⇒ Check compressor air inlet line for restrictions, brittleness, soft or sagging hose conditions etc. Repair as necessary. Refer to vehicle manufacturer's guidelines for inlet line size.

- ⇒ Check the engine air filter and service if necessary (if possible, check the air filter usage indicator).

(h) Poorly filtered inlet air (poor air quality to compressor).

? Check

- ⇒ Check for leaking, damaged or defective compressor air inlet components (e.g. induction line, fittings, gaskets, filter bodies, etc.). Repair inlet components as needed. Note: Dirt ingestion will damage compressor and is not covered under warranty.

(i) Compressor malfunction.

? Check

- ⇒ Replace the compressor only after making certain that none of the preceding conditions, 9.0 (a) through 9.0 (h), exist.

Symptom:	What it may indicate:	What you should do:
10.0 Air charging system doesn't build air.	(a) Governor malfunction*.	⇒ Go to Test 4 on page 27.
	(b) Restricted discharge line.	⇒ See 9.0(f).
	(c) Air dryer heater malfunction: exhaust port frozen open.	⇒ Replace air dryer heater.
	(d) Compressor malfunction.	⇒ Replace the compressor only after making certain the preceding conditions do not exist.

* Note: For the Bendix® DuraFlo™ 596 air compressor, not only the governor, but also the SV-1™ synchro valve used would need to be tested. See Bulletin TCH-001-048.

11.0 Compressor safety valve releases air (Compressor builds too much air).

(a) Restricted discharge line.

? Check

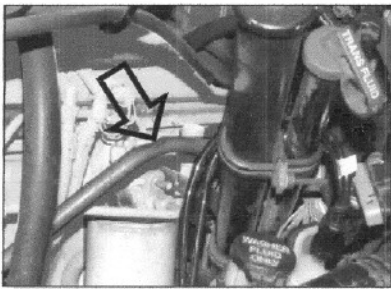

Damaged discharge line shown.

⇒ If discharge line is restricted:
 ⇒ By more than 1/16" carbon build up, replace the discharge line (see Table A, column 2, on page 15 for recommended size) and go to Test 3 on page 26.
 ⇒ By other restrictions (e.g. kinks). Replace the discharge line. See Table A, column 2, on page 15 for recommended size.

⇒ The discharge line must maintain a **constant slope** down from the compressor to the air dryer inlet fitting to avoid low points where ice may form and block the flow. If, instead, ice blockages occur at the air dryer inlet, insulation may be added here, or if the inlet fitting is a typical 90 degree fitting, it may be changed to a straight or 45 degree fitting. For more information on how to help prevent discharge line freeze-ups, see Bendix Bulletins TCH-08-21 and TCH-08-22 (Appendix B). Shorter discharge line lengths or insulation may be required in cold climates.

(b) Downstream air brake system check valves or lines may be blocked or damaged.

⇒ Inspect air lines and verify check valves are operating properly.

(c) Air dryer lines incorrectly installed.

⇒ Ensure discharge line is installed into the inlet of the air dryer and delivery is routed to the service reservoir.

(d) Compressor safety valve malfunction.



⇒ Verify relief pressure is 250 psi. Replace if defective.

(e) Compressor unloader mechanism malfunction.

⇒ Go to Test 6 on page 27.

(f) Governor malfunction.

⇒ Go to Test 4 on page 27.

Symptom:	What it may indicate:	What you should do:
<p>12.0 Air dryer safety valve releases air.</p>   <p>Technician removes governor.</p>	<p>(a) Restriction between air dryer and reservoir.</p> <p>(b) Air dryer safety valve malfunction.</p> <p>(c) Air dryer maintenance not performed.</p> <p>(d) Air dryer malfunction.</p> <p>(e) Improper governor control line installation to the reservoir.</p> <p>(f) Governor malfunction.</p>	<p>⇒ Inspect delivery lines to reservoir for restrictions and repair as needed.</p> <p>⇒ Verify relief pressure is at vehicle or component manufacturer specifications. Replace if defective.</p> <p>⇒ See Maintenance Schedule and Usage Guidelines (Table A, column 3, on page 15).</p> <p>⇒ Verify operation of air dryer. Follow vehicle O.E. maintenance recommendations and component Service Data information.</p> <p>⇒ Go to Test 5 on page 27.</p> <p>⇒ Go to Test 4 on page 27.</p>
<p>13.0 Reservoir safety valve releases air</p>	<p>(a) Reservoir safety valve malfunction.</p> <p>(b) Governor malfunction.</p> <p>(c) Compressor unloader mechanism malfunction.</p>	<p>⇒ Verify relief pressure is at vehicle or component manufacturer's specifications (typically 150 psi). Replace if defective.</p> <p>⇒ Go to Test 4 on page 27.</p> <p>⇒ Go to Test 6 on page 27.</p>
<p>14.0 Air dryer doesn't purge. (Never hear exhaust from air dryer.)</p>	<p>(a) Air dryer malfunction.</p> <p>(b) Governor malfunction.</p> <p>(c) Air brake system leakage.</p> <p>(d) Improper governor control line installation to the reservoir.</p>	<p>⇒ Verify operation of air dryer. Follow vehicle O.E. maintenance recommendations.</p> <p>⇒ Go to Test 4 on page 27.</p> <p>⇒ Go to Test 2 on page 26.</p> <p>⇒ Go to Test 5 on page 27.</p>
<p>15.0 Compressor constantly cycles (compressor remains unloaded for a very short time.)</p>	<p>(a) Air brake charging system maintenance not performed.</p> <p style="text-align: center;">? Check</p> <p>(b) Compressor unloader mechanism malfunction.</p> <p>(c) Air dryer purge valve or delivery check valve malfunction.</p> <p>(d) Air brake system leakage.</p>	<p>⇒ Available reservoir capacity may be reduced by build up of water etc. Drain and perform routine maintenance per Table A, columns 3 & 4, on page 15.</p> <p>⇒ Go to Test 6 on page 27.</p> <p>⇒ Verify operation of air dryer. Follow vehicle O.E. maintenance recommendations and component Service Data information.</p> <p>⇒ Go to Test 2 on page 26.</p>

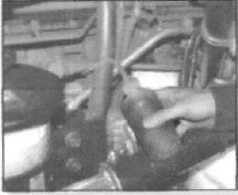
Symptom:	What it may indicate:	What you should do:
16.0 Compressor leaks air  Testing for leaks with soap solution.	(a) Compressor leaks air at connections or ports.	⇒ Check for leaking, damaged or defective compressor fittings, gaskets, etc. Repair or replace as necessary.
	(b) Compressor unloader mechanism malfunction.	⇒ Go to Test 6 on page 27.
	(c) Damaged compressor head gasket.	⇒ An air leak at the head gasket may indicate a downstream restriction such as a freeze-up or carbon blockage and/or could indicate a defective or missing safety valve. Find blockage (go to 9.0(f) for details.) and then replace the compressor. Do not re-use the safety valve without testing. See Symptom 12.0(a).
17.0 Compressor leaks coolant	(a) Improperly installed plugs or coolant line fittings.	⇒ Inspect for loose or over-torqued fittings. Reseal and tighten loose fittings and plugs as necessary. If overtightened fittings and plugs have cracked ports in the head, replace the compressor.
	(b) Damaged compressor head gasket.	⇒ An air leak at the head gasket may indicate a downstream restriction such as a freeze-up or carbon blockage and/or could indicate a defective or missing safety valve. Find blockage (go to 9.0(f) for details.) and then replace the compressor. Do not re-use the safety valve without testing. See Symptom 12.0(a).
	(c) Porous compressor head casting.	⇒ If casting porosity is detected, replace the compressor.
18.0 Noisy compressor (Multi-cylinder compressors only)	(a) Damaged compressor.	⇒ Replace the compressor.

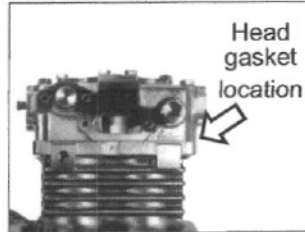

Other Miscellaneous Areas to Consider

This guide attempts to cover most compressor system problems. Here are some rare sources of problems not covered in this guide:

- Turbocharger leakage. Lubricating oil from leaking turbocharger seals can enter the air compressor intake and give misleading symptoms.

- Where a compressor does not have a safety valve installed, if a partial or complete discharge line blockage has occurred, damage can occur to the connecting rod bearings. Damage of this kind may not be detected and could lead to compressor problems at a later date.

Test 1: Excessive Oil Leakage at the Head Gasket

Exterior leaks at the head gasket are not a sign that oil is being passed into the air charging system. Oil weepage at the head gasket does not prevent the compressor from building air.

Observe the amount of weepage from the head gasket.

If the oil is only around the cylinder head area, it is acceptable (return the vehicle to service), but, if the oil weepage extends down to the nameplate area of the compressor, the gasket can be replaced.

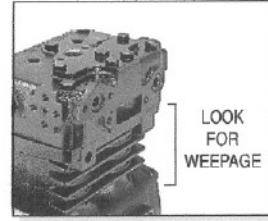

Test 2: Air Brake System and Accessory Leakage

Inspect for air leaks when working on a vehicle and repair them promptly.

Park the vehicle on level ground and chock wheels. Build system pressure to governor cut-out and allow the pressure to stabilize for one minute.

Step 1: Observe the dash gauges for two additional minutes without the service brakes applied.

Step 2: Apply the service brakes and allow the pressure to stabilize. Continue holding for two minutes (you may use a block of wood to hold the

pedal in position.) Observe the dash gauges.

If you see any noticeable decrease of the dash air gauge readings (i.e. more than 4 psi, plus two psi for each additional trailer) during either two minute test, repair the leaks and repeat this test to confirm that they have been repaired.

Air leaks can also be found in the charging system, parking brakes, and/or other components - inspect and repair as necessary.

Test 3: Air Compressor Discharge Temperature and Air Dryer Inlet Temperature*

Caution: The temperatures used in this test are not normal vehicle conditions.

Above normal temperatures can cause oil (as vapor) to pass through the air dryer into the air brake system.

This test is run with the engine at normal operating temperature, with engine at max. rpm. If available, a dyno may be used.

1. Allow the compressor to build the air system pressure to governor cut-in.
2. Pump the brakes to bring the dash gauge pressure to 90 psi.
3. Allow the compressor to build pressure from 95 to 105 psi gauge pressure and maintain this pressure range by cycling the brakes for five (5) minutes.

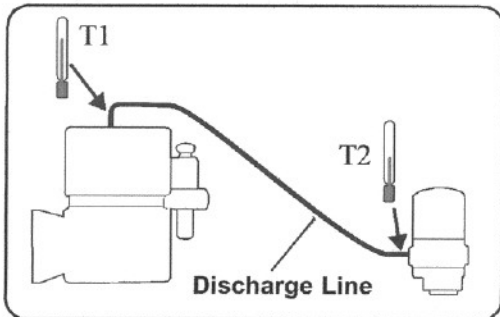

(* Note that only vehicles that have passed Test 2 would be candidates for this test.)

4. Then, while maintaining max rpm and pressure range, measure and record the surface temperature of the fittings:
 - ⇒ at the compressor discharge port. (T1).
 - ⇒ at the air dryer inlet fitting. (T2).
 Use a touch probe thermocouple for measuring the temperature.
5. See table below.
6. Retest before returning the vehicle to service.

T1 Compressor Discharge Fitting	T2 Air Dryer Inlet Fitting	Action
under 360°F	under 200°F	Temperatures are within normal range for this test, check other symptoms. Go to 4.0 (h).
under 360°F	over 200°F	This could indicate a discharge line problem (e.g. restriction). Call 1-800-AIR-BRAKE (1-800-247-2725) and speak with our Tech Team.
over 360°F	---	Compressor is running hot. Check coolant 4(f) and/or discharge line 4(g).

Tests (continued)

Test 4: Governor Malfunction

1. Inspect control lines to and from the governor for restrictions (e.g. collapsed or kinked). Repair as necessary.
2. Using a calibrated external gauge in the supply reservoir, service reservoir, or reservoir port of the D-2™ governor, verify cut-in and cut-out pressures are within vehicle OEM specification.
3. If the governor is malfunctioning, replace it.

Test 5: Governor Control Line

1. Ensure that the governor control line from the reservoir is located at or near the top of the reservoir. (This line, if located near the bottom of the reservoir, can become blocked or restricted by the reservoir contents e.g. water or ice.)
2. Perform proper reservoir drain intervals and air dryer cartridge maintenance per Maintenance Schedule and Usage Guidelines (Table A on page 15).
3. Return the vehicle to service.

Test 6: Compressor Unloader Leakage

Bendix® Compressors: Park vehicle, chock wheels, and follow all standard safety procedures. Remove the governor and install a fitting to the unloader port. Add a section of air hose (min 1ft long for a 1/2" diameter line) and a gauge to the fitting followed by a shut-off valve and an air source (shop air or small air tank). Open the shut

off and charge the unloader port by allowing air pressure to enter the hose and unload the compressor. Shut off the air supply and observe the gauge. A steady reading indicates no leakage at the unloader port, but a falling reading shows that the unloader mechanism is leaking and needs to be serviced.

Appendix A: Information about the BASIC Test Kit (Bendix PIN 5013711)

Bendix® Air System Inspection Cup (BASIC) Test Information

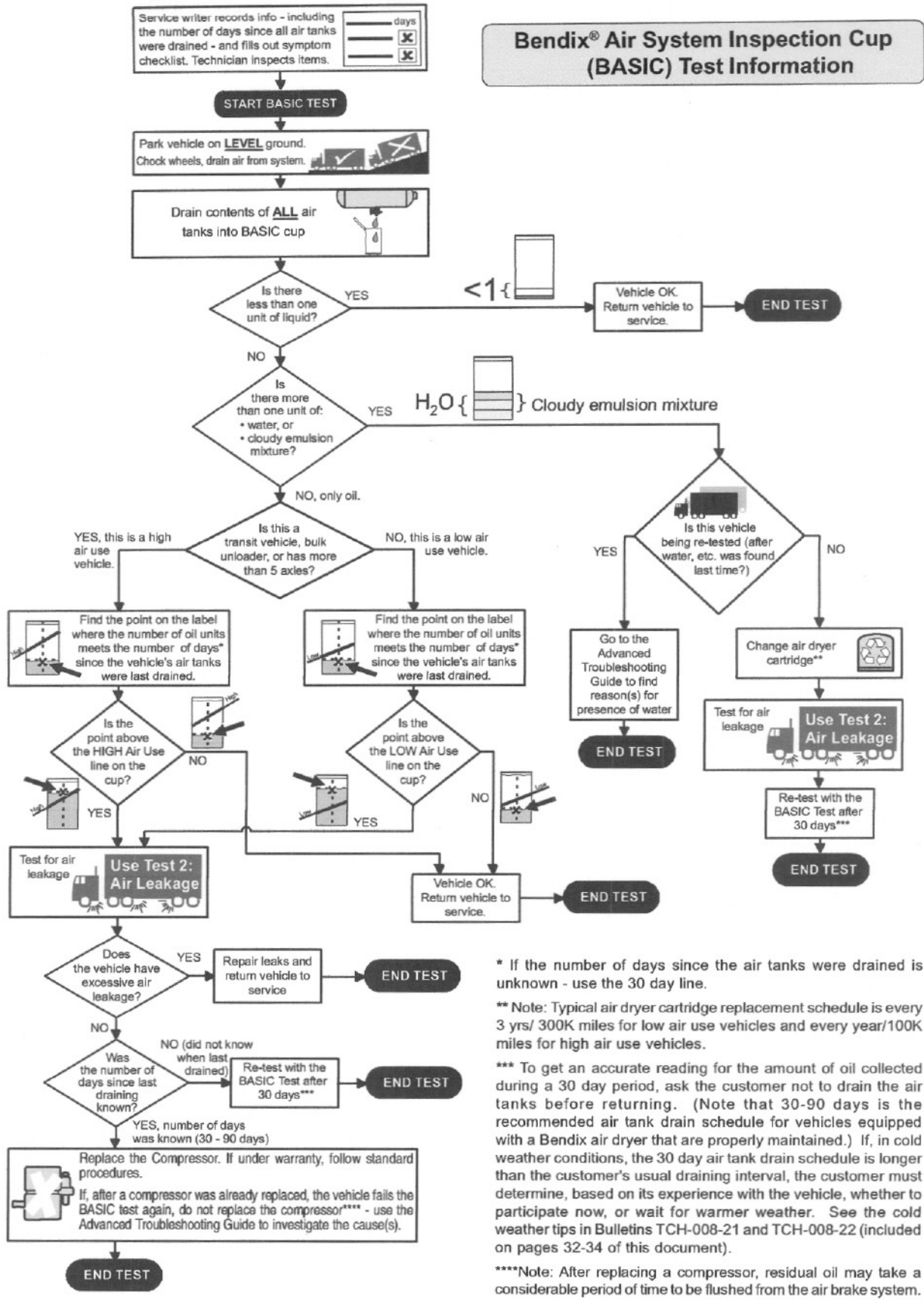

* If the number of days since the air tanks were drained is unknown - use the 30 day line.

** Note: Typical air dryer cartridge replacement schedule is every 3 yrs/ 300K miles for low air use vehicles and every year/100K miles for high air use vehicles.

*** To get an accurate reading for the amount of oil collected during a 30 day period, ask the customer not to drain the air tanks before returning. (Note that 30-90 days is the recommended air tank drain schedule for vehicles equipped with a Bendix air dryer that are properly maintained.) If, in cold weather conditions, the 30 day air tank drain schedule is longer than the customer's usual draining interval, the customer must determine, based on its experience with the vehicle, whether to participate now, or wait for warmer weather. See the cold weather tips in Bulletins TCH-008-21 and TCH-008-22 (included on pages 32-34 of this document).

****Note: After replacing a compressor, residual oil may take a considerable period of time to be flushed from the air brake system.

Filling in the Checklist for the Bendix® Air System Inspection Cup (BASIC) Test

Note: Follow all standard safety precautions. For vehicles using a desiccant air dryer.

The Service Writer fills out these fields with information gained from the customer

Number of Days Since Air Tanks Were Last Drained: _____ Date: _____ Vehicle #: _____
 Engine SN _____ Vehicle Used for: _____ Typical Load: _____ (lbs.)
 No. of Axles: ____ (tractor) ____ (trailer) No. of Lift Axles: ____ Technician's Name: _____

The Service Writer also checks off any complaints that the customer makes to help the Technician in investigating.

Customer's Complaint (Please check all that apply)	Checklist for Technician Have you confirmed complaint?
"Relay valve <input type="checkbox"/> leaks oil / <input type="checkbox"/> malfunctions"	<input type="checkbox"/> no <input type="checkbox"/> yes*
"Dash valve <input type="checkbox"/> leaks oil / <input type="checkbox"/> malfunctions"	<input type="checkbox"/> no <input type="checkbox"/> yes*
<input type="checkbox"/> "Air dryer leaks oil"	<input type="checkbox"/> no <input type="checkbox"/> yes*
<input type="checkbox"/> "Governor malfunction"	<input type="checkbox"/> no <input type="checkbox"/> yes*
<input type="checkbox"/> "Oil in gladhands"	<input type="checkbox"/> no <input type="checkbox"/> yes*
how much oil did you find? _____	
<input type="checkbox"/> "Oil on ground or vehicle exterior"	<input type="checkbox"/> no <input type="checkbox"/> yes*
amount described: _____	
<input type="checkbox"/> "Short air dryer cartridge life" replaces every: _____ <input type="checkbox"/> miles, <input type="checkbox"/> kms, or <input type="checkbox"/> months	
<input type="checkbox"/> "Oil in air tanks" amount described: _____	
We will measure amount currently found when we get to step B of the test.	
<input type="checkbox"/> "Excessive engine oil loss" amount described: _____	
Is the engine leaking oil?	<input type="checkbox"/> no <input type="checkbox"/> yes*
Is the compressor leaking oil?	<input type="checkbox"/> no <input type="checkbox"/> yes*
<input type="checkbox"/> Other complaint: _____	
<input type="checkbox"/> No customer complaint.	

The Technician checks boxes for any of the complaints that can be confirmed.

* Note: A confirmed complaint above **does NOT** mean that the compressor must be replaced. The full BASIC test below will investigate the facts.

BASIC test starts here:

STEP A - Select one:

- This is a low air use vehicle: Line haul (single trailer) with 5 or less axles, or
- This is a high air use vehicle: Garbage truck, transit bus, bulk unloader, or line haul with 6 or more axles.

Then go to Step B.

The Technician selects the air use category for the vehicle. This decided which of the two acceptance lines on the cup will be used for the test below.

STEP B - Measure the Charging System Contents

1. Park and chock vehicle on level ground. Drain the air system by pumping the service brakes.
2. Completely drain **ALL** the air tanks into a single **BASIC** cup.
3. If there is less than one unit of contents total, end the test now and return the vehicle to service. Vehicle passes.
4. **If more than one oil unit of water (or a cloudy emulsion mixture) is found:**
 - (a) Change the vehicle's air dryer cartridge - see Footnote 1.
 - (b) Conduct the 4 minute leakage test (Step D),
 - (c) **STOP the inspection, and check the vehicle again after 30 days** - see Footnote 2.

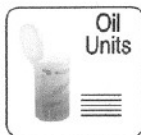

For an accurate test, the contents of all the air tanks on the vehicle should be used.

Note for returning vehicles that are being retested after a water/cloudy emulsion mixture was found last time and the air dryer cartridge replaced: If more than one oil unit of water or a cloudy emulsion mixture is found **again**, stop the BASIC test and consult the air dryer's Service Data sheet troubleshooting section.

Otherwise, go to Step C.

Footnote 1: Note: Typical air dryer cartridge replacement schedule is every 3 yrs/ 300K miles for low air use vehicles and every year/100K miles for high air use vehicles.

Footnote 2: To get an accurate reading for the amount of oil collected during a 30 day period, ask the customer not to drain the air tanks before returning. (Note that 30-90 days is the recommended air tank drain schedule for vehicles equipped with a Bendix air dryer that are properly maintained.) If, in cold weather conditions, the 30 day air tank drain schedule is longer than the customer's usual draining interval, the customer must determine, based on its experience with the vehicle, whether to participate now, or wait for warmer weather. See the cold weather tips in Bulletins TCH-008-21 and TCH-008-22 (included in Appendix B of the advanced troubleshooting guide).

Appendix A continued: Information about the BASIC Test Kit (Bendix PIN 5013711)

Filling in the Checklist for the Bendix® Air System Inspection Cup (BASIC) Test

Note: Follow all standard safety precautions. For vehicles using a desiccant air dryer.

STEP C - How to Use the BASIC Test

The Technician uses the chart (label) on the BASIC test cup to help decide the action to take, based on the amount of oil found. Use the lower acceptance line for low air use vehicles, and upper line for high air use vehicles (from Step A).

1. Record days since air tanks were last drained.

days

2. Record amount of oil found:

units

3. Action to take

If number of days is: 30-60 days (high air use) or 30-90 days (low air use) →	if oil level is at or below acceptance line for number of days →	System OK. Return to service. STOP TEST
	if oil level is above acceptance line for number of days →	Go to Step D
Otherwise ... → (if the number of days is unknown, or outside the limits above)	if oil level is at or below 30-day acceptance line →	System OK. Return to service. STOP TEST
	if oil level is above 30-day acceptance line →	Stop inspection. Test again after 30 days. STOP + CK. See Footnote 2.

BASIC Test Example

An oil level of 4 units in a sixty-day period is within the acceptance area (at or below the line) for both low and high air use vehicles. Return the vehicle to service.

The Technician looks for the point where the number of days since the air tanks were drained meets the oil level. If it is at or below the (low or high use) acceptance line, the vehicle has passed the test. If the point is above the line we go to the leakage test.

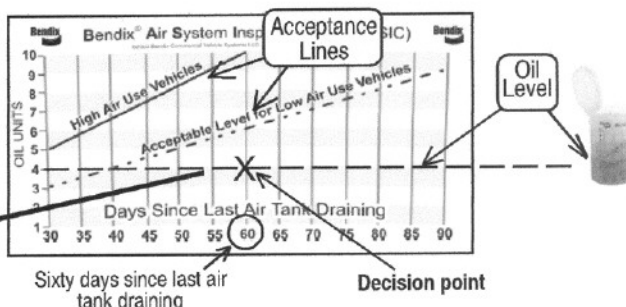

Air leakage is the number one cause of compressors having to pump excessive amounts of air, in turn run too hot and pass oil vapor along into the system. Here the Technician conducts a four-minute test to see if leakage is a problem with the vehicle being tested.

STEP D - Air Brake System Leakage Test

Park the vehicle on level ground and chock wheels. Build system pressure to governor cut-out and allow the pressure to stabilize for one minute.

- 1: Observe the dash gauges for two additional minutes without the service brakes applied.
- 2: Apply service brakes for two minutes (allow pressure to stabilize) and observe the dash gauges.

If you see any noticeable decrease of the dash air gauge readings repair leaks. Repeat this test to confirm that air leaks have been repaired and return vehicle to service. Please repeat BASIC test at next service interval. Note: Air leaks can also be found in the charging system, parking brakes, and/or other components - inspect and repair as necessary.

If no air leakage was detected, and if you are conducting this test after completing Step C, go to Step E.

STEP E - If no air leakage was detected in Step D

Replace the compressor.

Note: If the compressor is within warranty period, please follow standard warranty procedures. Attach the completed checklist to warranty claim.

The Technician only reaches Step E if the amount of oil found, for the amount of time since the air tanks were last drained exceeds the acceptance level, AND the vehicle passes the four-minute leakage test (no noticeable leakage was detected).

Technical Bulletin



Bulletin No.: TCH-008-021

Effective Date: 11/1/92

Page: 1 of 2

Subject: **Air Brake System - Cold Weather Operation Tips**

As the cold weather approaches, operators and fleets alike begin to look to their vehicles with an eye toward "winterization", and particularly what can be done to guard against air system freeze-up. Here are some basic "Tips" for operation in the cold weather.

Engine Idling

Avoid idling the engine for long periods of time! In addition to the fact that most engine manufacturers warn that long idle times are detrimental to engine life, winter idling is a big factor in compressor discharge line freeze-up. Discharge line freeze-ups account for a significant number of compressor failures each year. The discharge line recommendations under "Discharge Lines" are important for all vehicles but are especially so when some periods of extended engine idling can not be avoided.

Discharge Lines

The discharge line should slope downward from the compressor discharge port without forming water traps, kinks, or restrictions. Cross-overs from one side of the frame rail to the other, if required, should occur as close as possible to the compressor. Fitting extensions must be avoided. Recommended discharge line lengths and inside diameters are dependent on the vehicle application and are as follows.

Typical P&D, School Bus and Line Haul

The maximum discharge line length is 16 feet.

<u>Length</u>	<u>I.D. Min.</u>	<u>Other Requirements</u>
6.0-9.5 ft.	½ in.	None
9.5-12 ft.	½ in.	Last 3 feet, including fitting at the end of the discharge line, must be insulated with ½ inch thick closed cell polyethylene pipe insulation.
12-16 ft.	5/8 in.	Last 3 feet, including fitting at the end of the discharge line, must be insulated with ½ inch thick closed cell polyethylene pipe insulation.

If the discharge line length must be less than 6 feet or greater than 16 feet, contact your local Bendix representative.

High Duty Cycle Vehicles (City Transit Coaches, Refuse Haulers, Etc.)

The maximum discharge line length is 16 feet.

<u>Length</u>	<u>I.D. min.</u>	<u>Other Requirements</u>
10-16 ft.	½ in.	None

If the discharge line length must be less than 10 feet or greater than 16 feet, contact your local Bendix representative.

System Leakage

Check the air brake system for excessive air leakage using the Bendix "Dual System Air Brake Test and Check List" (BW1279). Excessive system leakage causes the compressor to "pump" more air and also more moisture into the brake system.

Reservoir Draining (System Without Air Dryer)

Routine reservoir draining is the most basic step (although not completely effective) in reducing the possibility of freeze-up. **All reservoirs** in a brake system can accumulate water and other contamination and must be drained! The best practice is to drain all reservoirs daily. When draining reservoirs; turn the ENGINE OFF and drain ALL AIR from the reservoir, better still, open the drain cocks on all reservoirs and leave them open over night to assure all contamination is drained (reference Service Data Sheet SD-04-400 for Bendix Reservoirs). If automatic drain valves are installed, check their operation **before** the weather turns cold (reference Service Data Sheet SD-03-2501 for Bendix® DV-2™ Automatic Drain Valves). It should be noted that, while the need for daily reservoir draining is eliminated through the use of an automatic drain valve, periodic manual draining is still required.

Alcohol Evaporator or Injector Systems

Check for proper operation of these systems by monitoring alcohol consumption for a few days (Reference Service Data Sheet SD-08-2301 for the Bendix Alcohol Evaporator). Too little means the system is not receiving adequate protection and too much simply wastes alcohol. As a general guide, these systems should consume approximately 1 to 2 ounces of alcohol per hour of compressor loaded time (compressing air). City pick-up and delivery vehicles will operate with the compressors loaded (compressing air) more while compressors on highway vehicles will be loaded less. These figures are approximate and assume that air system leakage is within the limits of the Bendix "Dual System Air Brake Test and Check List" (BW1279). Last but not least, begin using alcohol several weeks prior to freezing weather to ensure that the system is completely protected. Use only methanol alcohol, such as Bendix "Air Guard", in evaporators or injectors.

Air Dryers

Make certain air brake system leakage is within the limits stated in BW1279. Check the operation and function of the air dryer using the appropriate Service Data Sheet for the air dryer.

AD-9™ Air Dryer	Service Data Sheet SD-08-2412
AD-4™ Air Dryer	Service Data Sheet SD-08-2407
AD-2™ Air Dryer	Service Data Sheet SD-08-2403
AD-IP™ Air Dryer	Service Data Sheet SD-08-2414
AD-SF™ Air Dryer	Service Data Sheet SD-08-2415
Trailer System-Guard™ Air Dryer	Service Data Sheet SD-08-2416



Technical Bulletin

Bulletin No.: TCH-008-022

Effective Date: 1/1/1994

Page: 1 of 1

Subject: **Additional Cold Weather Operation Tips for the Air Brake System**

Last year we published Bulletin PRO-08-21 which provided some guidelines for "winterizing" a vehicle air brake system. Here are some additional suggestions for making cold weather vehicle operation just a little more bearable.

Thawing Frozen Air Lines

The old saying; "Prevention is the best medicine" truly applies here! Each year this activity accounts for an untold amount of unnecessary labor and component replacement. Here are some Do's and Don'ts for prevention and thawing.

Do's

1. Do maintain freeze prevention devices to prevent road calls. Don't let evaporators or injectors run out of methanol alcohol or protection will be degraded. Check the air dryer for proper operation and change the desiccant when needed.
2. Do thaw out frozen air lines and valves by placing the vehicle in a warmed building. This is the only method for thawing that will not cause damage to the air system or its components.
3. Do use dummy hose couplings on the tractor and trailer.
4. Do check for sections of air line that could form water traps. Look for "drooping" lines.

Don'ts

1. Do not apply an open flame to air lines and valves. Beyond causing damage to the internal nonmetallic parts of valves and melting or burning non-metallic air lines. **WARNING: THIS PRACTICE IS UNSAFE AND CAN RESULT IN VEHICLE FIRE!**
2. Do not introduce (pour) fluids into air brake lines or hose couplings ("glad hands"). Some fluids used can cause immediate and severe damage to rubber components. Even methanol alcohol, which is used in Alcohol Evaporators and Injectors, should not be poured into air lines. Fluids poured into the system wash lubricants out of valves, collect in brake chambers and valves and can cause malfunction. Loss of lubricant can affect valve operating characteristics, accelerate wear and cause premature replacement.
3. Do not park a vehicle outside after thawing its air system indoors. Condensation will form in the system and freeze again. Place the vehicle in operation when it is removed to the outdoors.

Supporting Air and Electrical Lines

Make certain tie wraps are replaced and support brackets are re-assembled if removed during routine maintenance. These items prevent the weight of ice and snow accumulations from breaking or disconnecting air lines and wires.

Automatic Drain Valves (System without Air Dryer)

As we stated last year, routine reservoir draining is the most basic step (although not completely effective) in reducing the possibility of freeze-up. While automatic drain valves relieve the operator of draining reservoirs on a daily basis, these valves **MUST** be routinely checked for proper operation. Don't overlook them until they fail and a road call is required.



Bendix® AD-1™ and AD-2™ Air Dryers

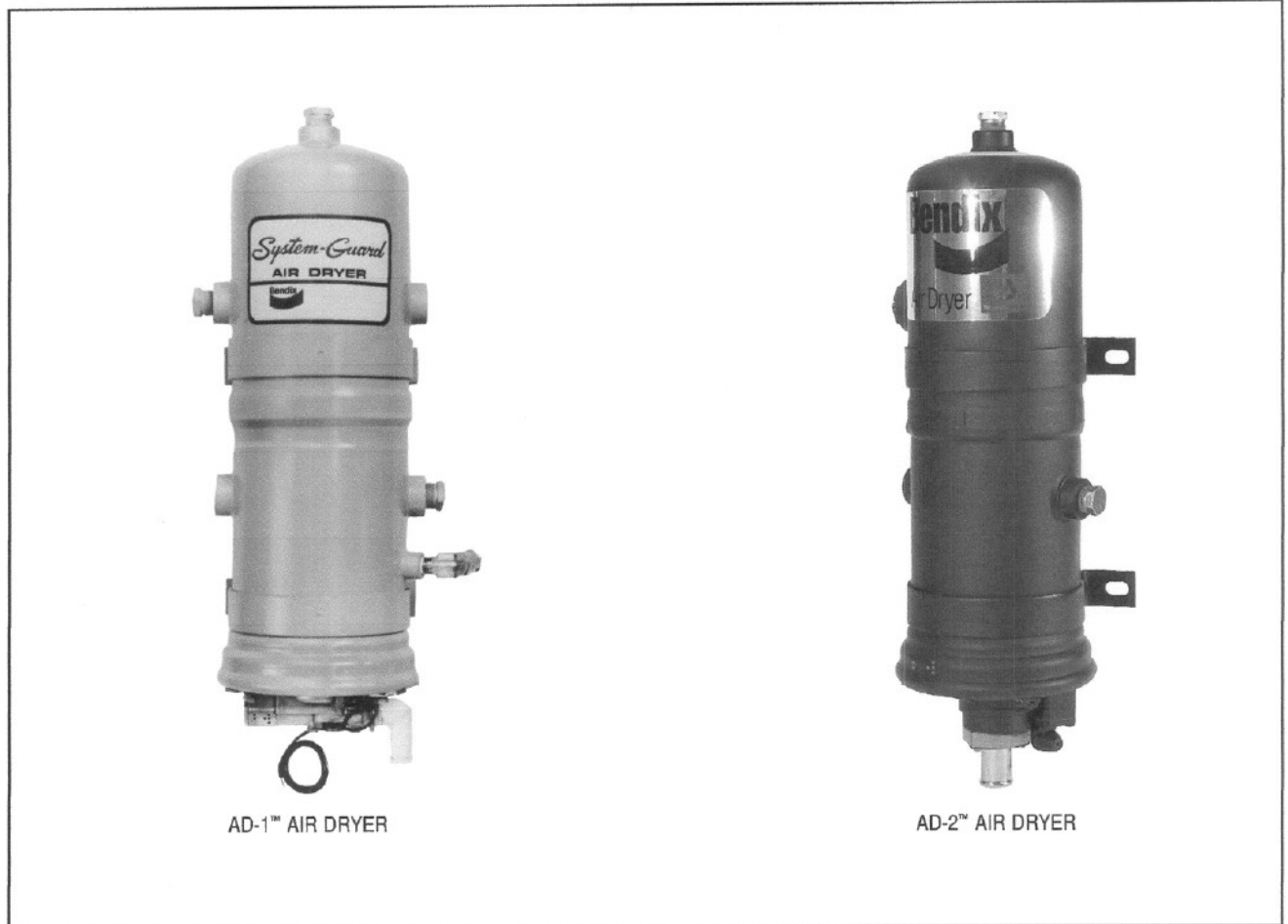

FIGURE 1

The air dryer collects and removes moisture and contaminants before the air reaches the first reservoir. It is distinctly different than a reservoir drain valve or aftercooler in that it provides "dry air" for the air brake system. The daily draining of the system's reservoirs is no longer necessary, thus reducing maintenance considerably when compared to an air brake system without an air dryer.

In a system without an air dryer, the life of air brake components is substantially reduced because of contact with water and oil in the system and since the air dryer removes water and oil in vapor form, life of the component devices is substantially increased when the air dryer is used.

The air dryer can be used on most highway vehicles where normal compressor loaded time is 90 seconds or less and unloaded time is 30 seconds or more. If the compressor remains loaded for long periods of time, such as on a transit bus, certain changes in the purge volume of the dryer must be made. For more information regarding increase of the purge volume, contact our Engineering Department, in Elyria, Ohio.

The air dryer is installed in the discharge line between the compressor and the first reservoir. The unit must be mounted vertically and mounting brackets are provided and can be adjusted to meet installation requirements.

The housing assembly consists of two cylindrical steel stampings welded together. For piping convenience, two inlet ports, one reservoir port and one purge volume port are provided in the AD-2™ air dryer. The side outlet port of the AD-2™ air dryer incorporates an integral single check valve with the top port used for the addition of purge volume. (Refer to Figure 1)

A safety valve mounted in the housing assembly protects against excessive pressure build-up within the housing.

The desiccant sealing plate assembly is located mid-way in the housing assembly and houses a replaceable ball-type single check. Also located in the plate assembly is the purge orifice.

The desiccant cartridge and aluminum oil separator filter are removable and comprise a complete serviceable unit.

The desiccant beads, which are referred to as the "drying bed", are a drying substance that has the unique property of exposing a tremendous surface area in proportion to its bulk. One pound of the desiccant beads has about two million square feet of adsorptive area made up of a large number of submicroscopic cavities in each bead. Each desiccant bead adsorbs or collects moisture.

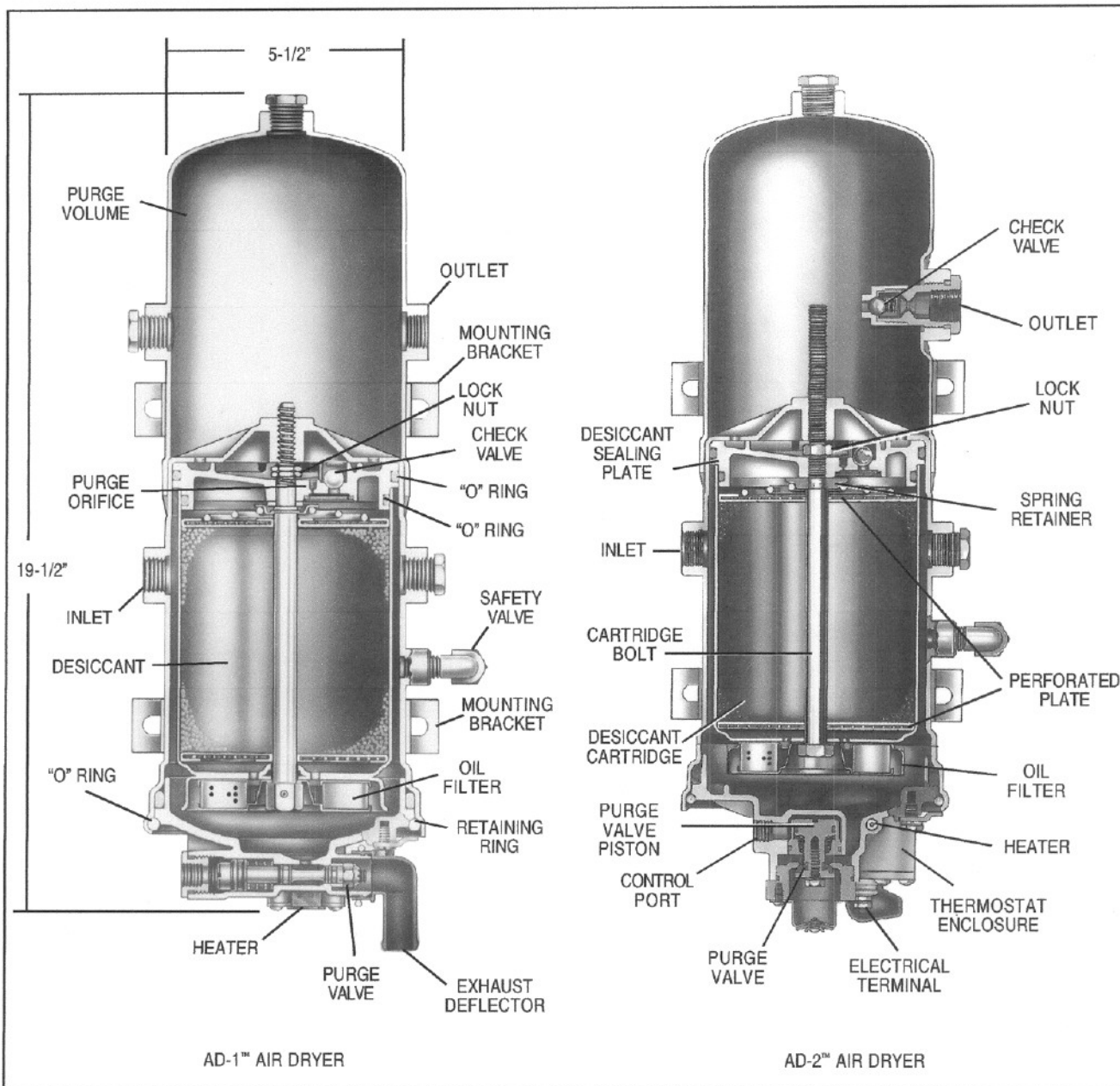

FIGURE 2 - SECTIONAL VIEWS

The desiccant beads are held in place by steel perforated plates and filter cloths. The top plate is held in place by a spring, and the bottom plate rests on a shoulder approximately 1/8" from the bottom of cartridge housing.

The end cover assembly is retained by a lock ring, cap screws and retainers and houses the purge valve and heater assembly if so equipped.

The heater and thermostat assembly prevent freeze-up in the purge drain valve when the dryer is used in severe winter conditions. The heater and thermostat assembly is standard in the AD-2™ air dryer and was optional equipment for the AD-1™ air dryer. The 12 volt, 60 watt and 24 volt, 60 or 120 watt DC heater and thermostat assembly has an operating range between 45°F and 85°F.

NOTE: The heater and thermostat assembly provided with the AD-2™ air dryer has a 3/16" diameter threaded electrical terminal protected by a boot. The AD-1™ air dryer assembly incorporates a #16 gauge lead wire. Both types are serviceable. The heater and thermostat assembly should be connected to the "on" position of the engine control or ignition switch and protected with the proper size fuse. For details on installation, please refer to the "Installation" section.

OPERATION

The operation of the air dryer can best be described by separating the operation into two cycles; the charge cycle and the purge cycle.

Charge Cycle (Figure 3) Compressor in Compressing Cycle - With the compressor in its "loaded" or compressing cycle, air from the compressor enters the air dryer through the discharge line. When the air, along with the water and contaminants, enter the air dryer, the velocity or speed of the air reduces substantially and much of the entrained liquid drops to the bottom or sump of the air dryer. The initial air flow is toward the bottom of the dryer, but air flow direction changes 180° at the bottom of the air dryer, dropping some water and oil.

The air now passes through the oil separator filter which removes oil and foreign material but does not remove water vapor. At this point, the air remains saturated with water.

The filtered air and vapors penetrate the desiccant drying bed and the adsorption process begins. Water vapor is removed from the air by the desiccant.

The unsaturated "dry" air passes through the ball check valve and purge orifice into the purge volume. From the purge volume air flows through an outlet check valve, and into the first reservoir.

NOTE: The AD-1™ air dryer does not incorporate an integral outlet check valve. The single check valve in an AD-1™ air dryer installation would be located in the line between the AD-1™ air dryer outlet port and the first reservoir.

Purge Cycle: (Figure 4) When desired system pressure is reached, the governor cuts out, pressurizing the unloader cavity of the compressor which unloads the compressor (non-compressing cycle). The line connecting the governor unloader port to the end cover purge valve port (bottom of the air dryer) is also pressurized, opening the exhaust of the purge valve to atmosphere. With the exhaust of the purge valve open, contaminants in the discharge line and dryer sump are purged, or forced past the open exhaust out to atmosphere.

The reverse air flows across the desiccant and starts the removal process of moisture from the desiccant surface. Dry air flowing from the purge volume through the purge orifice and across the drying bed further dries the desiccant.

The combination of these reverse flows strips the water vapor from the desiccant (drying bed). This normally takes between 15-30 seconds.

The desiccant becomes activated from this cycle and is now ready for another charge cycle, which occurs when the compressor returns to the compressing cycle. It is for this reason the air dryer must be purged for 30 seconds, after receiving moisture saturated air for a maximum of 90 seconds from a 12 CFM compressor.

WARNING!

This air dryer is intended to remove moisture and other contaminants normally found in the air brake system. Do not inject alcohol, anti-freeze, or other de-icing substances into or upstream of the air dryer. Alcohol is removed by the dryer, but reduces the effectiveness of the device to dry air. Use of other substances can damage the air dryer and may void the warranty.

PREVENTIVE MAINTENANCE AND CHECKING SERVICEABILITY

Important: Review the warranty policy before performing any intrusive maintenance procedures. An extended warranty may be voided if intrusive maintenance is performed during this period.

Every 900 operating hours or 25,000 miles or every three (3) months:

1. Check for moisture in the air brake system by opening reservoirs, drain cocks, or valves and checking for presence of water. If moisture is present, the desiccant may require replacement; however, the following conditions can also cause water accumulation and should be considered before replacing the desiccant:

AD-2™ AIR DRYER OPERATIONAL CHARGE CYCLE

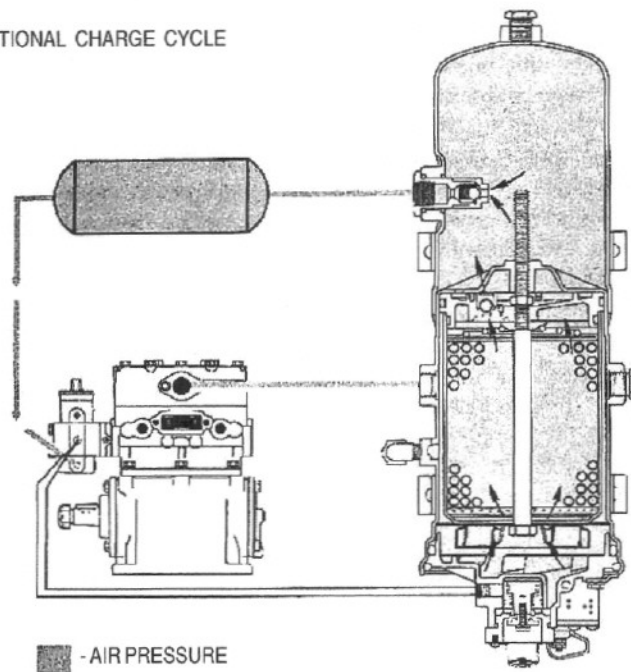

FIGURE 3

AD-2™ AIR DRYER OPERATIONAL PURGE CYCLE

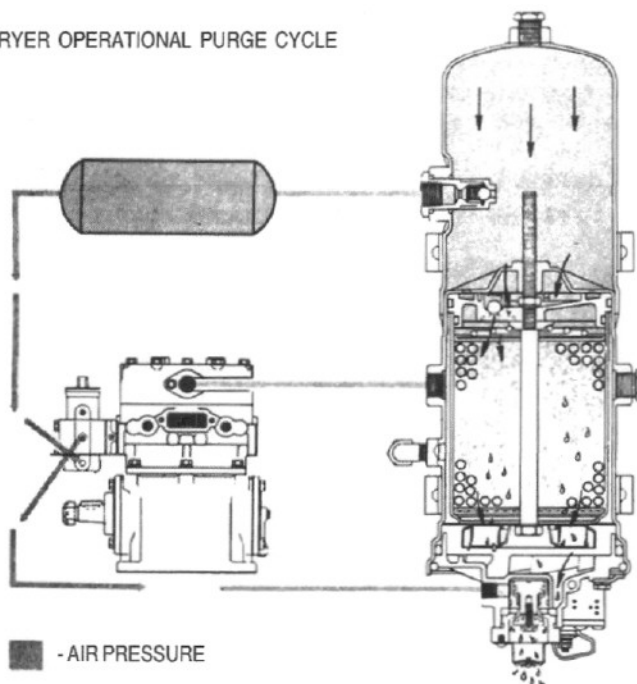

FIGURE 4

- A. An outside air source has been used to charge the system. This air did not pass through the drying bed.
- B. Air usage is exceptionally high and not normal for a highway vehicle. This may be due to accessory air demands or some unusual air requirement that does not allow the compressor to load and unload (compressing and non-compressing cycle) in a normal fashion. Check for high air system leakage.
- C. The air dryer has been installed in a system that has been previously used without an air dryer. This type system will be saturated with moisture and several weeks of operation may be required to dry it out.
- D. Location of the air dryer is too close to the air compressor. Refer to "Installation" section.
- E. In areas where more than a 30° range of temperature occurs in one day, small amounts of water can accumulate in the air brake system due to condensation. Under these conditions, the presence of small amounts of moisture is normal and should not be considered as an indication that the dryer is not performing properly.

Note also that a small amount of oil in the system may be normal and should not, in itself, be considered a reason to replace the desiccant; oil stained desiccant can often function adequately.

- 2. Check mounting bolts for tightness.
- 3. Check the operation of the integral single check valve in the AD-2™ air dryer or the "in line" check valve used with the AD-1™ air dryer. Build the air system to governor cut-out and observe the test air gauge installed in the #1 reservoir. A rapid loss of pressure could indicate a failed check valve. This can be confirmed by checking at the purge valve exhaust. (Note: Purge valve will be



FIGURE 5

open when governor cut-out pressure is reached. Allow two minutes for purge cycle before testing the check valve.)

- 4. Check for excessive leakage at the purge valve by coating the exhaust with a soap solution while the compressor is loaded. (compressing air)
- 5. Check the operation of the safety valve by pulling the exposed stem while the compressor is loaded. (compressing air) There must be an exhaust of air while the stem is held and the valve should reseat when the stem is released.
- 6. Check all lines and fittings leading to and from the air dryer for leakage and integrity.
- 7. Check the operation of the end cover heater and thermostat assembly during cold weather operation as follows:

A. Electric Power to the Dryer

With the ignition or engine control "on", check for power at the dryer's electrical terminal (see Figure 16) with a voltmeter or test light. If there is no voltage, look for a blown fuse, broken wires, or corrosion in the vehicle wiring harness.

B. Thermostat and Heater

1. Turn off the ignition switch and cool the end cover assembly to below 40°F. With an ohmmeter check the resistance between the electrical terminal and the aluminum of the end cover (see Figure 16). This resistance should be 2.0 - 4.0 ohms for a 12 volt end cover, 8.1 -13 ohms for a 24 volt, 60 watt cover, and 4.0 - 7.0 ohms for a 24 volt, 120 watt end cover.

2. Warm the end cover assembly to over 90°F and check the resistance as above. This resistance should exceed 1,000 ohms.

If these resistances are within the limits, the thermostat and heater are operating properly.

If these resistances are outside the limits, proceed to Step C to determine the cause.

C. Heater Element

With the ignition or engine control switch "off", remove the thermostat cover (see Figure 17). With an ohmmeter check the resistance between the aluminum of the end cover and the heater post (see Figure 17). For a 12 volt end cover, the resistance should be 2.0 - 2.8 ohms. For a 24 volt, 60 watt end cover, 8.1 - 11.1 ohms, and for a 24 volt, 120 watt end cover, 4.0 - 4.6 ohms. If the heater resistance is outside these ranges, a new or remanufactured end cover should be installed, since the heater element cannot be serviced.

If the heater resistance is within the limits the thermostat should be replaced (Kit Number 102637) or a new or remanufactured end cover installed.

D. Reassembly

Reinstall the thermostat cover according to Figure 17. Take special care to assure the rubber spacer and the gasket are correctly installed, to assure proper operation.

8. Every 7200 hours; 200,000 miles or every 24 months, change the desiccant cartridge.

NOTE: The desiccant change interval may vary from vehicle to vehicle. Although typical desiccant cartridge life is two years, many will perform adequately for three to four years. In order to take maximum advantage of desiccant life and assure that replacement occurs only when necessary, it is important that Serviceability Checks 1 - 7 be performed.

WARNING! PLEASE READ AND FOLLOW THESE INSTRUCTIONS TO AVOID PERSONAL INJURY OR DEATH:

When working on or around a vehicle, the following general precautions should be observed **at all times**.

1. Park the vehicle on a level surface, apply the parking brakes, and always block the wheels. Always wear safety glasses.
2. Stop the engine and remove ignition key when working under or around the vehicle. When working in the engine compartment, the engine should be shut off and the ignition key should be removed. Where circumstances require that the engine be in operation, **EXTREME CAUTION** should be used to prevent personal injury resulting from contact with moving, rotating, leaking, heated or electrically charged components.
3. Do not attempt to install, remove, disassemble or assemble a component until you have read and thoroughly understand the recommended procedures. Use only the proper tools and observe all precautions pertaining to use of those tools.
4. If the work is being performed on the vehicle's air brake system, or any auxiliary pressurized air systems, make certain to drain the air pressure from all reservoirs before beginning **ANY** work on the vehicle. If the vehicle is equipped with an AD-IS™ air dryer system or a dryer reservoir module, be sure to drain the purge reservoir.
5. Following the vehicle manufacturer's recommended procedures, deactivate the electrical system in a manner that safely removes all electrical power from the vehicle.
6. Never exceed manufacturer's recommended pressures.
7. Never connect or disconnect a hose or line containing pressure; it may whip. Never remove a component or plug unless you are certain all system pressure has been depleted.

8. Use only genuine Bendix® replacement parts, components and kits. Replacement hardware, tubing, hose, fittings, etc. must be of equivalent size, type and strength as original equipment and be designed specifically for such applications and systems.
9. Components with stripped threads or damaged parts should be replaced rather than repaired. Do not attempt repairs requiring machining or welding unless specifically stated and approved by the vehicle and component manufacturer.
10. Prior to returning the vehicle to service, make certain all components and systems are restored to their proper operating condition.

REPLACING OR REBUILDING THE AD-1™ AND AD-2™ AIR DRYER

GENERAL

If, after completing the routine serviceability tests, it has been determined that one or more components of the air dryer requires replacement or maintenance, refer to page 13 to ascertain the appropriate kit(s) needed. When rebuilding or replacing components of the air dryer use only genuine Bendix replacement parts or kits.

REMOVAL OF DESICCANT CARTRIDGE AD-1™ & AD-2™ AIR DRYER

CAUTION!

1. Loosen the air line to the control port of air dryer and allow the trapped air to escape to atmosphere. After the air escapes, remove the control line from the air dryer.
2. Loosen the delivery line from the delivery port or outlet of the air dryer. After the pressure drops, remove the delivery line. Loosen the delivery check valve from this port to relieve any trapped air above the desiccant plate assembly. If the AD-1™ air dryer has an external check valve at the delivery port loosen it to relieve air pressure.
3. Disconnect the heater wire.
4. Remove any exhaust silencers or the exhaust check valve cover from the base of the air dryer. Using a hex socket and wrench, loosen the purge valve assembly and allow any trapped air to escape. Slowly unscrew the purge valve and remove it.
5. Check all ports to insure that air is not trapped in the air dryer by powdered desiccant material.

Air Dryer End Cover Removal Procedure

Warning - The AD-2™ air dryer cartridge contains a high spring load. When replacing the AD-2™ air dryer cartridge or performing any maintenance requiring end cover removal follow the procedure outlined below.

End Cover Removal

1. Loosen the three cap screws on the end cover and turn the retaining clamps aside (cap screws may be left finger tight).
2. Locate the notch in the air dryer shell. While pushing the end cover up into the dryer, insert the blade of a screwdriver in the notch and slowly pry out the retaining ring. If the cartridge bolt has loosened the cartridge spring may exert a force on the end cover retaining ring making removal of the retaining ring and end cover difficult. This spring force will prohibit the end cover moving up into the dryer shell when pushed up. Warning: This same force can also cause the end cover to come out of the air dryer shell unexpectedly during the removal process. Exercise extreme caution to prevent bodily injury.
3. Do not stand or lay directly under the end cover while servicing. Assure adequate clearance between the end cover and other surfaces to prevent hand injury if the end cover dislodges rapidly during removal. NOTE: BE CERTAIN THE DESICCANT SEALING PLATE ASSEMBLY COMES OUT WITH THE CARTRIDGE.

CAUTION: Before attempting to remove the desiccant sealing plate, measure the cartridge bolt from the top of the desiccant plate lock nut to the end of the bolt threads. If that measurement is approximately 3-3/16 inches, proceed with the disassembly.

If the bolt measures approximately 1-9/16 inches, disassemble using **CAUTION**. Approximately **75 pounds of spring force** will remain against the desiccant plate when the lock nut reaches the end of the bolt thread and is removed.

REMOVING AND REBUILDING THE AD-1™ AND AD-2™ AIR DRYER DESICCANT SEALING PLATE

Before the desiccant cartridge can be replaced or rebuilt the desiccant sealing plate must be removed. It is recommended that all non-metallic parts be replaced when

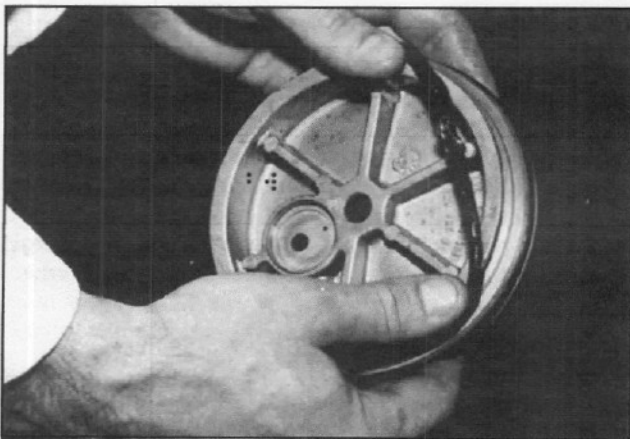

FIGURE 6 - DESICCANT SEALING PLATE

the plate is removed. In the past, three methods have been employed, to secure the desiccant sealing plate to the desiccant cartridge: a Tru Arc retaining ring, two special thin nuts, and the latest method, a single hex lock nut. Removing the securing device will permit the desiccant plate to be separated from the desiccant cartridge. After removing the desiccant cartridge:

1. Remove the two o-rings from the desiccant plate and discard them.
2. Remove the ball check valve retaining clip and remove and discard the rubber ball valve.
3. Clean the desiccant plate thoroughly using a quality commercial solvent, making sure the purge orifice and check valve seat are clean.
4. Install a new ball check valve and replace the retaining clip and screw (Figure 5).
5. Thoroughly lubricate the two new o-rings and install them in their respective grooves in the purge plate (Figure 6).
6. Set the desiccant sealing plate aside for reinstallation on the desiccant cartridge.



FIGURE 7 - REPLACEMENT DESICCANT CARTRIDGE

REINSTALLING THE DESICCANT CARTRIDGE AD-1™ AND AD-2™ AIR DRYER

If the desiccant cartridge is to be replaced as an assembly rather than rebuilt (see desiccant cartridge rebuilding instructions), the cartridge removed from the air dryer.

The current revision replacement desiccant cartridge is shown in Figure 7. All prior revisions of the cartridge will interchange with no modifications to either air dryer.

Prior to installing the new replacement cartridge in the air dryer, the following steps must be followed:

1. Carefully remove the lock nut from the cartridge bolt using an 11/16 in. open end or box wrench. **IMPORTANT:** Care **must** be taken not to allow the cartridge bolt to slip out of the cartridge when the lock nut is removed. Loss of desiccant material will occur should this happen.
2. Install the previously rebuilt desiccant sealing plate on the cartridge bolt so that the ball check retaining clip remains visible (see Figure 15-1 & 15-2).
3. While holding the cartridge bolt reinstall the lock nut on the cartridge bolt. **IMPORTANT:** Before tightening the lock nut down make certain that the shoulder (the unthreaded portion) of the cartridge bolt extends slightly above the perforated desiccant plate (see Figure 12).
4. By tightening the lock nut, draw the desiccant sealing plate down into the desiccant cartridge until the shoulder of the desiccant sealing plate is against the cartridge shell. (See Figure 15)

REBUILDING THE DESICCANT CARTRIDGE

IMPORTANT: Only the current revision desiccant cartridges (See Figure 7) can be rebuilt. Current revision desiccant cartridges are identified positively by the Bendix trademark BW stamped in the hex head of the cartridge bolt, and by the letters and number AD-2™ air dryer displayed on the bottom face of the oil filter. **If an old revision desiccant cartridge is removed from the air dryer, it should be replaced with a complete current revision desiccant cartridge.**

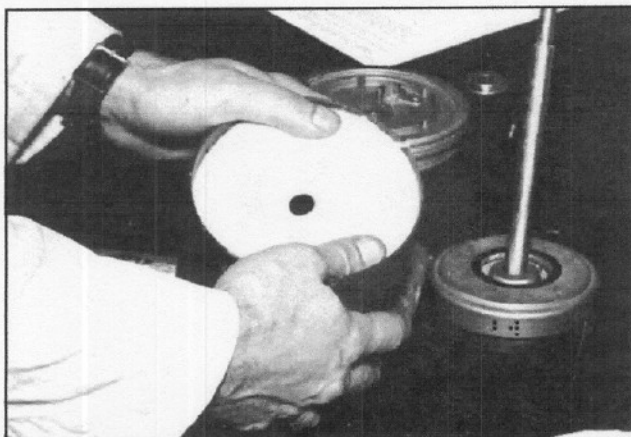

FIGURE 8 - ASSEMBLY OF DESICCANT CARTRIDGE

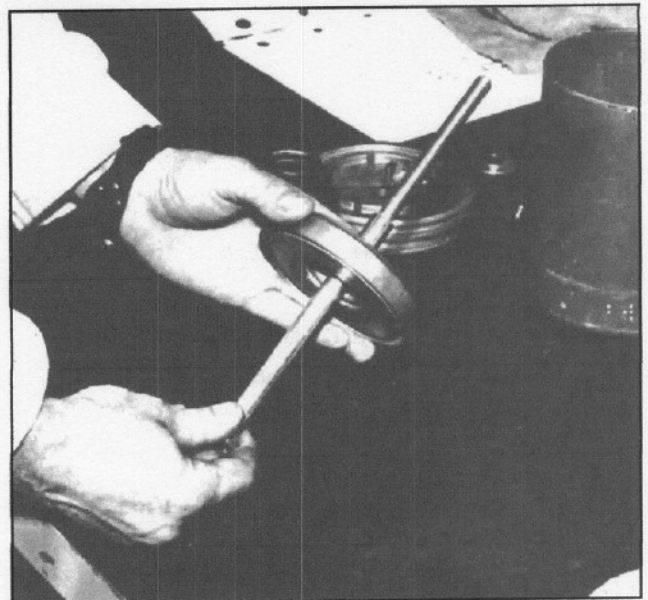

FIGURE 9

DISASSEMBLY OF DESICCANT CARTRIDGE

1. Carefully remove and discard the lock nut on top of the desiccant sealing plate. (The plate is spring loaded; see "Caution" note in "Removal of Desiccant Cartridge" section.)
2. Remove the desiccant sealing plate and rebuild it as outlined under the Removing and Rebuilding the Desiccant Sealing Plate section of this manual.
3. Remove and retain the spring, spring seat, bolt, and cartridge shell. Discard the oil separator filter, the two perforated plates and desiccant material.



FIGURE 10

4. Insert one of the perforated plates into the cartridge, **cloth side up**, and tap it firmly to the bottom. (Cloth always faces desiccant material.) (See Figure 8)

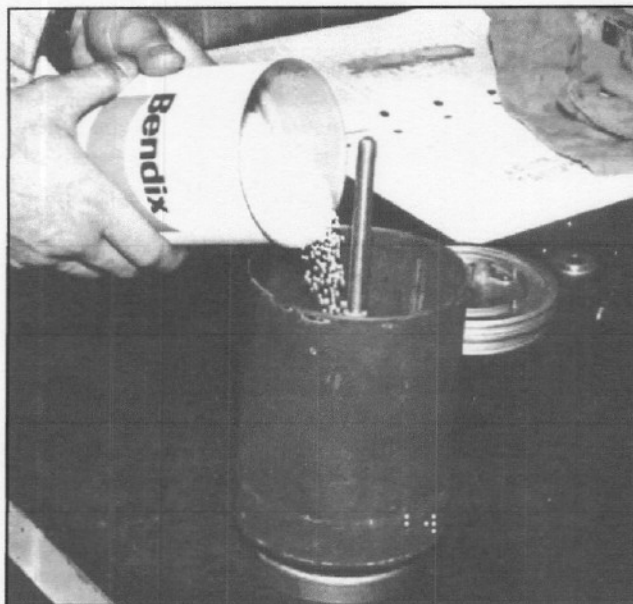

FIGURE 11

5. Slide oil separator filter over the cartridge bolt with the gasket surface next to the shell. (See Figure 9)
6. Install the bolt with the oil separator into the bottom of the shell and through center hole of the perforated plate in the bottom of the shell. (See Figure 10)
7. Pour the **entire package** of desiccant material into the shell, making **sure none is lost**. Handle carefully so that the bolt does not fall out. (See Figure 11)
8. Level the desiccant material and install second perforated plate **cloth side down**. (Make sure the shoulder of the bolt is centered, and extends slightly above the top of the perforated plate.) (See Figure 12)
NOTE: If the shoulder of the bolt does not extend above the perforated plate tap the side of the desiccant container.
9. Set the conical spring on top of the perforated plate (large diameter down - small diameter up.)
10. Place the spring retainer on top of the spring (See Figure 13)
11. Install the previously rebuilt desiccant sealing plate on the cartridge bolt so that the ball check retaining clip is in view.
12. Using the lock nut draw the assembly together to approximately half of the spring's free height. While slowly turning the cartridge, tap the side of the shell with a plastic mallet (See Figure 14). This allows the desiccant material to settle properly into place. Continue to tighten the nut, making sure all items are properly aligned. Tighten nut firmly using an 11/16" socket or box wrench. (See Figures 15-1, 15-2)

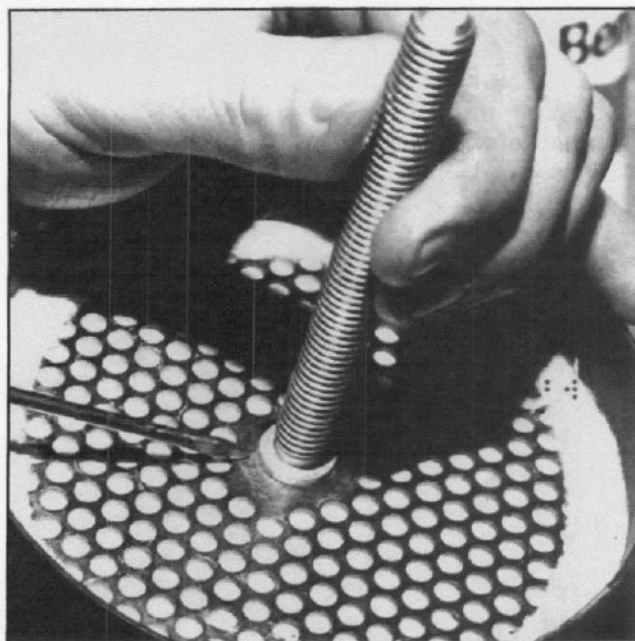

FIGURE 12



FIGURE 13

DISASSEMBLY

REBUILDING THE AD-1™ AIR DRYER END COVER ASSEMBLY

To remove the end cover assembly from the air dryer follow steps 1-6 under the section of this manual entitled Removal of Desiccant Cartridge AD-1™ and AD-2™ air dryer. Before rebuilding the end cover, clean the exterior thoroughly using a quality commercial solvent.

1. Remove and discard the large o-ring around the end cover.
2. Remove the exhaust elbow and clamp.
3. Remove the cap nut and discard the cap nut o-ring.
4. Place the handle of a large screwdriver in a vise and secure it.
5. Place the slot in the plunger (cap nut end) over the blade of the screwdriver, hold it securely and remove the nut from the plunger using a 1/2" socket wrench.
6. Remove the plunger, spring and valve. Discard the valve.
7. Clean and inspect the plunger bore and the valve seat.
8. Remove and discard the three o-rings from the plunger. Clean the plunger.

NOTE: If during the serviceability checks it was determined that the heater and thermostat were defective, use the following procedure. It is not necessary to replace this assembly each time the purge valve is rebuilt.

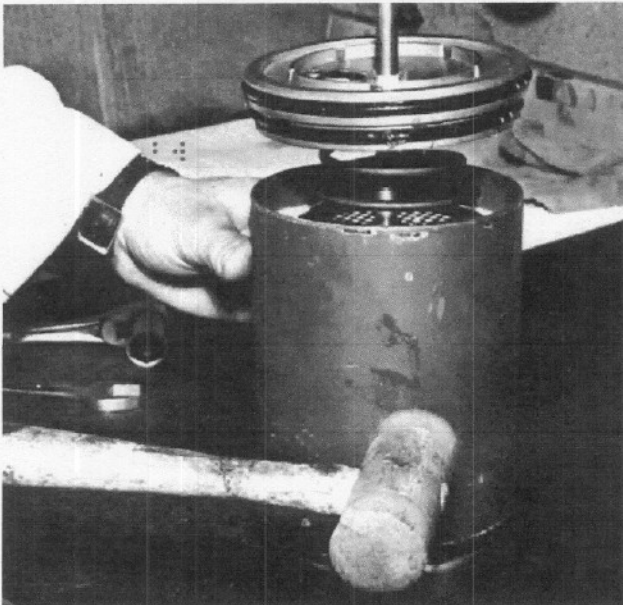

FIGURE 14

9. Remove the two screws that secure the shield or thermostat retaining clip to the end cover.
10. Remove the shield or clip and the thermostat and inspect the bore for corrosion.

10

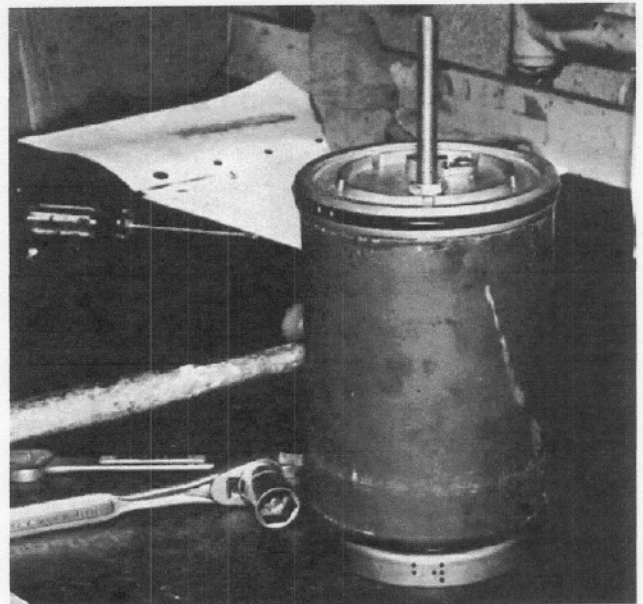

FIGURE 15-1

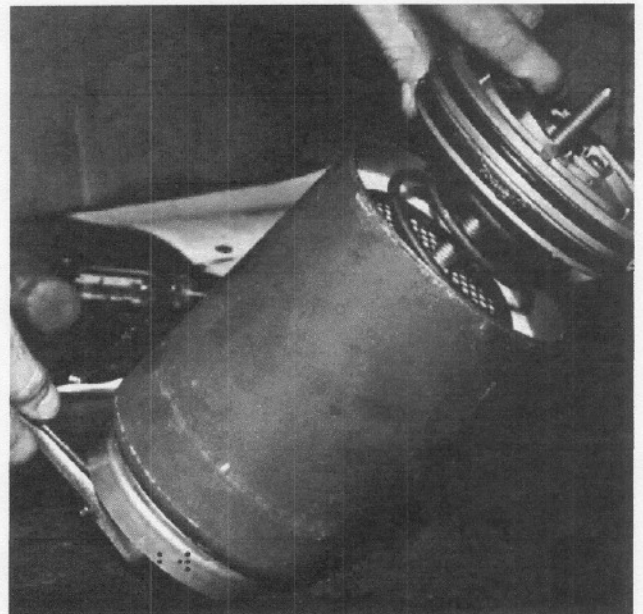

FIGURE 15-2

11. Remove the square cut seal ring at the bottom of the thermostat bore.
12. Remove the screw, retaining clip, o-ring, and the heater element. Inspect the bore for corrosion and if necessary, clean it.

ASSEMBLY

13. Install the heater element, securing it in the end cover with the retainer clip and screw.
14. Install the square cut seal ring in the thermostat bore.

15. Install the thermostat metal side down in the end cover bore and secure it in place using the retaining clip or shield and the two screws.
16. Lubricate and install the o-rings on the plunger and cap nut.
17. Lubricate the plunger bore and install the spring and plunger (through the cap nut end).
18. Install the valve on the plunger, making certain the chamfered end of the valve is in contact with the metal seat of the body.
19. Using the screwdriver held in the vise, as described in Steps 4 & 5, compress the plunger into the bore while installing and tightening the nut.
20. Install the cap nut and tighten it.
21. Lubricate and install the large diameter o-ring around the end cover assembly.

REBUILDING THE AD-2™ AIR DRYER END COVER

ASSEMBLY

To remove the end cover assembly from the air dryer follow steps 1-6 under the section of this manual entitled Removal of Desiccant Cartridge AD-1™ and AD-2™ Air Dryer. Before rebuilding the end cover, clean the exterior thoroughly using a quality commercial solvent.

DISASSEMBLY

1. Remove and discard the large o-ring around the end cover assembly.
2. Remove the single #6-32 screw securing the exhaust diaphragm and separate the diaphragm, washer and screw. Discard the diaphragm.
3. Remove the three #6-32 screws securing the exhaust cover and remove the exhaust cover.
4. Remove the purge valve assembly, the large hex cap nut, from the end cover and discard both o-rings around the cap nut.
5. Using a 7/16" socket wrench and a large screwdriver, remove the 1/4"-20 hex head cap screw which holds the assembly together.
6. Separate cap screw, purge valve, purge valve piston and the piston return spring.
7. Discard the piston o-ring, the purge valve, and the piston return spring.
8. Wash all remaining parts in a commercial solvent, making sure all surfaces, bores, ports, and passages are clean and dry before assembly.

NOTE: If during the serviceability checks it was determined that the thermostat was defective, use the following procedure. It is not necessary to replace this unit each time the end cover is rebuilt. Use thermostat kit. (See Figure 17)

9. Remove nut(2), then lockwasher(3), plain washer(4) and o-ring(5). Discard o-ring and retain other parts.
10. Remove and retain four Phillips head screws(7) and cover(6).
11. Remove and discard gasket(10).
12. Remove and retain spacer(11).
13. Cut uninsulated thermostat wire at Point B. (Figure 17), remove and discard thermostat and terminal assembly(1).
14. Clean remaining wire attached to heater terminal.
15. Clean thermostat "pocket" in end cover(9).

ASSEMBLY

16. Cut uninsulated lead of new thermostat(1) at Point A (Figure 17).
17. Install thermostat in end cover "pocket" and position uninsulated leads next to each other.
18. Using a soldering heat sink, clamp uninsula-leads at Point B and solder leads with straight rosin core solder. DO NOT USE ACID CORE SOLDER. Clean excess solder off end cover.
19. Install thermostat terminal(1) in cover(6).
20. Install o-ring(5), washer(4), lockwasher(3) and nut(2). Torque nut to 20-30 inch pounds.
21. Install spacer(11) over thermostat(1).
22. Install gasket(7) and cover(6) and secure cover to end cover(9) using screws(7) and lockwashers(8).
23. Torque to 30-40 inch pounds.
24. Test thermostat as follows:
 - A. At a temperature above 85°F. check resistance between thermostat terminal(1) and end cover(9). Resistance should be 200,000 ohms or greater; if not, check for solder "path" short.
 - B. Chill entire end cover assembly to 35°F. or below and check resistance again. Resistance should be 2-15 ohms.
25. Lubricate the piston o-ring and install it on the piston.
26. Lubricate the piston bore.
27. Install the purge piston return spring and piston.
28. Install the purge valve in the large cap nut so that the rubber portion rests on the metal seat of the cap nut.
29. Secure the valve to the piston using the 1/4"-20 cap screw and lockwasher and torque to 50 inch pounds.
30. Lubricate and install the two cap nut o-rings.

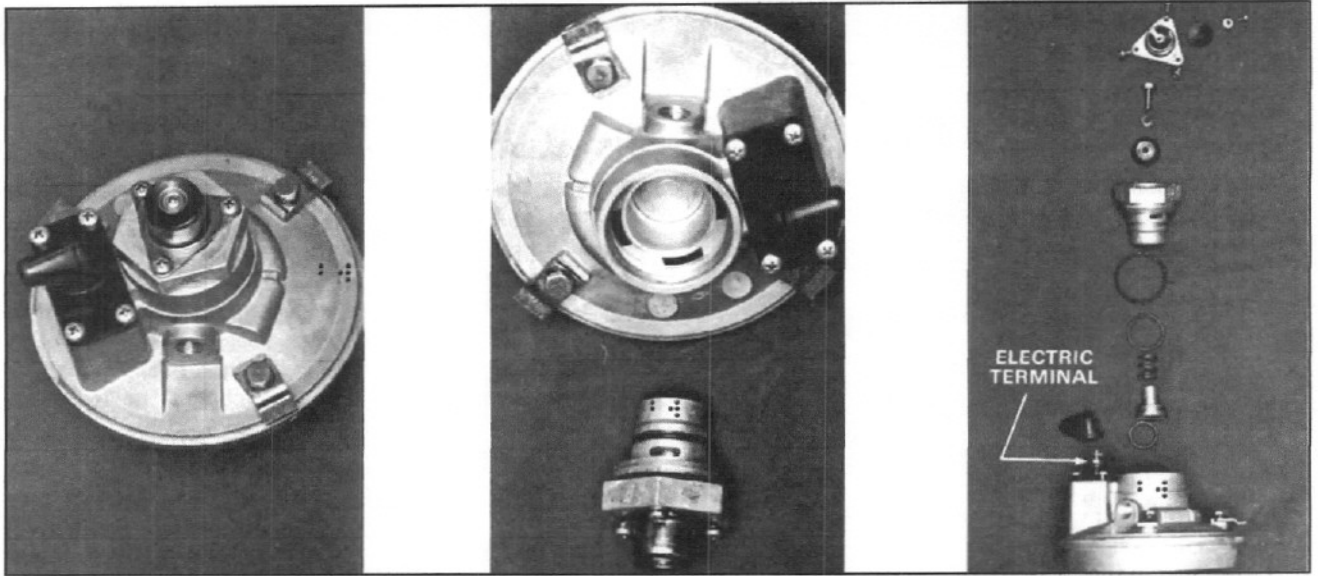

FIGURE 16 - AD-2™ AIR DRYER END COVER

31. Lubricate the cap nut threads and the cap nut bore of the end cover and install the cap nut, torquing it to 180-250 inch pounds.
32. Secure the exhaust diaphragm to the exhaust cover using the #6-32 Phillips head screw and diaphragm washer.
33. Secure the exhaust cover to the purge valve hex head cap nut using the #6-32 Phillips head screws.
34. Lubricate and install the large diameter o-ring around the end cover assembly.

REBUILDING THE AD-2™ AIR DRYER OUTLET PORT CHECK VALVE

1. Make certain the vehicle is safely parked. Block the wheels if necessary.
2. Locate and remove the line connected to the outlet port of the AD-2™ air dryer.
3. Remove the check valve from the outlet port. (See Figure 2)

4. Remove the rubber sealing ring from the external threaded portion of the body and discard it.
5. Disassemble the check valve by unscrewing the body halves and note the order of the removal of the parts.
6. Discard and replace the check valve, valve spring and metal seal washer.
7. Wash all parts in a quality commercial solvent, making sure all surfaces are clean and dry prior to reassembly.
8. Coat all parts with a film of barium base lubricant such as Bendix piece number 246671 which is supplied with the maintenance kit.
9. Reassemble the check valve and torque the body halves to between 200 and 225 inch pounds.
10. Reinstall the check valve in the AD-2™ air dryer outlet port and reconnect the line leading to the first reservoir.

REINSTALLING THE DESICCANT CARTRIDGE AD-1™ AND AD-2™ AIR DRYER

1. Wipe the inside of the dryer clean. If a solvent is used, be certain that no residue is left in the shell.
2. Check to be certain a film of barium base grease is present on the o-rings and install the cartridge and purge plate assembly into the body. Engage the bolt and tighten to 375 inch pounds or 32 foot pounds torque.
3. Check the end cover o-ring to be certain it is clean and lubricate the o-ring with a barium base lubricant such as Bendix 246671. Install the o-ring on the end cover and install the end cover in the dryer body.

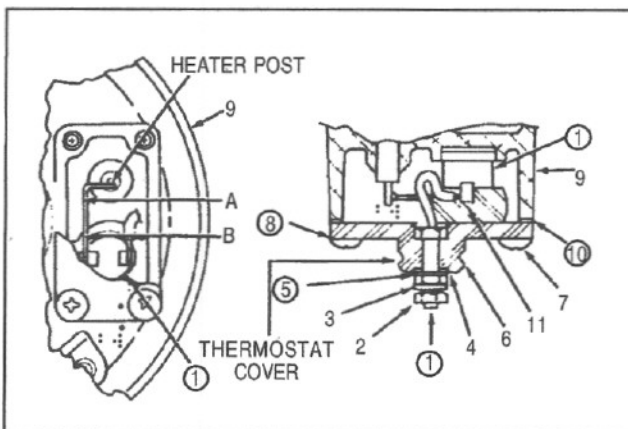

FIGURE 17

INSTALLATION OF AD-1 AND AD-2 AIR DRYER

1. Install the air dryer in the compressor discharge line as close to the supply (first) reservoir as possible. The discharge line between the compressor and air dryer must not exceed 20 feet in length nor less than six feet in length for a two cylinder compressor or ten feet in length for a single cylinder compressor. Six feet of discharge line and a 90 cubic inch reservoir can be used in lieu of ten feet of discharge line for single cylinder compressors.

The discharge line should slope downward from the compressor to the air dryer inlet to avoid water traps and to allow drainage to the air dryer. (If the 90 cubic inch reservoir is used, it should also be mounted and plumbed to avoid water traps and to allow drainage into the air dryer.) Discharge lines may be either be copper tubing or high temperature hose. However, Bendix compressors require a minimum of four feet of copper tubing extending from the discharge port. The balance of the discharge line may be either copper tubing or high temperature hose.

2. Locate outside the engine compartment in an area of air flow when the vehicle is in motion. Do not mount near exhaust system or other heat-producing components and avoid road-splash areas. Provide 20 cm (8 in.) clearance below dryer for servicing.
3. Mount vertically, with purge valve exhaust toward the ground, away from the frame and other components. Connect a hose to the exhaust cover if necessary, since this valve may expel rust and scale particles as well as condensate and oil collected in the dryer.
4. Connect the purge valve control port to one of the governor unloader ports. This line should be routed such that no water traps are formed.
5. For the dryers with a 3/4-14 or 1 - 11-1/2 dryseal outlet port, a check valve must be placed between the purge volume and the first downstream reservoir. (Dryers with 1/2-14 dryseal outlet ports have a built-in check valve.)
6. Connect a fused #16 gauge wire from the "on" position of the engine control or ignition switch to the heater

MAINTENANCE KIT FOR THE AIR DRYER

- 286718 DESICCANT CARTRIDGE REFILL KIT
This kit can only be used on new revision cartridges. See the cartridge rebuild section of this manual for proper identification of current revision cartridge. This kit contains the necessary parts to rebuild the cartridge and the desiccant sealing plate.
- 287313 DESICCANT CARTRIDGE REPLACEMENT KIT
This kit contains a factory replacement desiccant cartridge and the parts necessary to rebuild the desiccant sealing plate.
- 285519 AD-1™ AIR DRYER PURGE VALVE MAINTENANCE KIT
This kit contains the parts necessary to rebuild the AD-1™ air dryer end cover purge valve only.
- 287053 AD-2™ AIR DRYER PURGE VALVE MAINTENANCE KIT
This kit contains the parts necessary to rebuild the AD-2™ air dryer end cover purge valve.
- 287298 AD-2™ AIR DRYER CHECK VALVE MAINTENANCE KIT
This kit contains the components necessary to rebuild the inline single check valve that is used in AD-1™ air dryer installations must be serviced separately.
- 288918 THERMOSTAT COVER REPLACEMENT KIT
This kit contains the parts required to replace the non-metallic thermostat cover only. This kit is used to replace a damaged cover and does not contain thermostat parts.
- 102657 THERMOSTAT MAINTENANCE KIT
This kit contains the necessary components to rebuild the thermostat assembly in the AD-2™ air dryer.
- 101900 REMANUFACTURED DESICCANT CARTRIDGE AND DESICCANT SEALING PLATE.
This unit allows for complete exchange, as a unit, of the cartridge and desiccant plate.

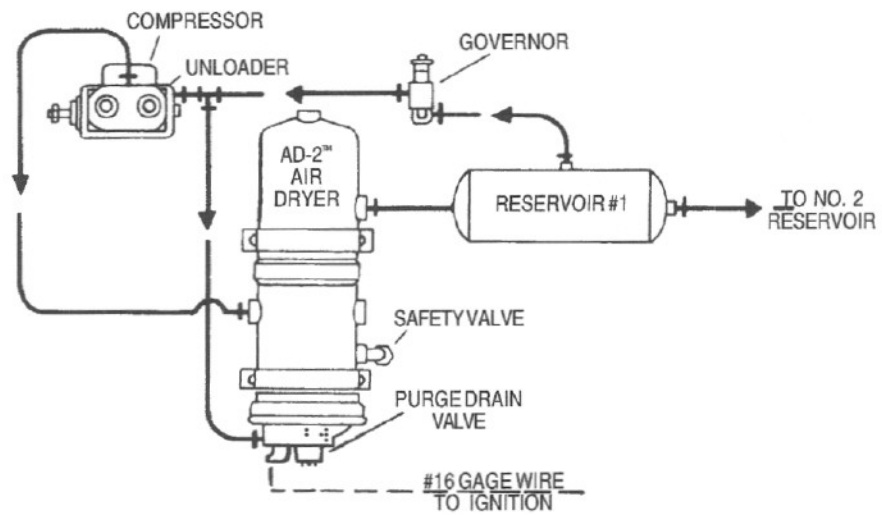
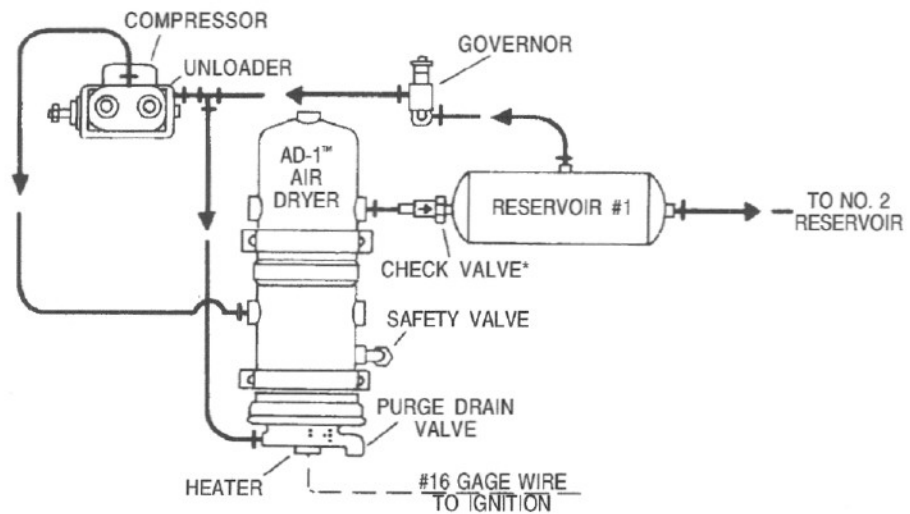

FIGURE 18 - TYPICAL INSTALLATION FOR THE AD-2™ AIR DRYER



* (NOTE) A CHECK VALVE MUST BE PLACED BETWEEN THE AIR DRYER AND NO.1 RESERVOIR

FIGURE 19 - TYPICAL INSTALLATION FOR THE AD-1™ AIR DRYER

2. Water in vehicle reservoirs.

3. Safety valve on air dryer "popping off" or exhausting air.

- D. Defective governor.
- E. Leaking purge valve in air dryer end cover (control side).
- F. Compressor unloader mechanism leaking excessively.

- A. Desiccant requires replacement.
- B. Improper discharge line length or improper line material.
- C. Air system charged from outside air source (outside air not passing through air dryer).
- D. Air dryer not purging (see Symptom #5).
- E. Purge (air exhaust) time insufficient due to excessive system leakage (see causes for Symptom #1).
- F. Air dryer/vehicle application requires additional purge volume.
- G. Air dryer not compatible with vehicle air system requirement - (Improper air dryer/vehicle application).

- A. Desiccant cartridge plugged or saturated.
- B. Defective check valve between air dryer outlet port and first reservoir. (in standard AD-2" air dryer, check valve in outlet port.)
- C. Defective fittings, hose or tubing between air dryer and first reservoir.

- D. Test governor for proper cut-in or cut-out pressures and excessive leakage in both positions.
- E. Remove end cover. Apply 120 psi at control port. Soap both sides around purge valve to test for control piston leakage. (Permissible leakage - 1" bubble in 5 seconds.)
- F. Remove air strainer or fitting from compressor inlet cavity. With compressor **unloaded**, check for unloader piston leakage. Slight leakage permissible.

- A. Replace desiccant cartridge.
- B. Minimum of six-foot metal tubing for two-cylinder compressor; ten-foot for one-cylinder compressor. Flex hose can be substituted at ratio of 1-1/2' flex hose for each 1' of metal.
- C. If system must have outside air fill provision, outside air should pass through air dryer. (Unused inlet on air dryer can be used.) **Use of this should be minimized.**
- D. See cause and remedy for Symptom #5.
- E. Check causes and remedies for Symptom #1.
- F. When compressor is loaded (compressing) longer than 90 seconds during normal operation, additional purge volume may be needed. (Before proceeding, contact Bendix representation for consultation.)
- G. Air dryer requires **minimum purge time of 30 seconds**. If compressor stays loaded longer than 90 seconds and additional purge volume is added, longer purge time is required. Air dryer efficiency will decrease as compressor loaded time increases beyond 120 seconds, during normal operation of the vehicle. (This limitation assumes a compressor of approximately 12 CFM and engine operation at 1600-1900 RPM.) The air dryer will accommodate occasional longer loaded times, such as initial system build-up.

- A. Check compressor for excessive oil passing and/or correct compressor installation. Repair or replace as necessary. Rebuild or replace cartridge.
- B. Test to determine if air is passing through check valve. Repair or replace.
- C. Check to determine if air is reaching first reservoir. Inspect for kinked tubing or hose. Check for undrilled or restricted hose or tubing fittings.